

# Operation Manual

MARINE SE

4 Cylinder / 6 Cylinder

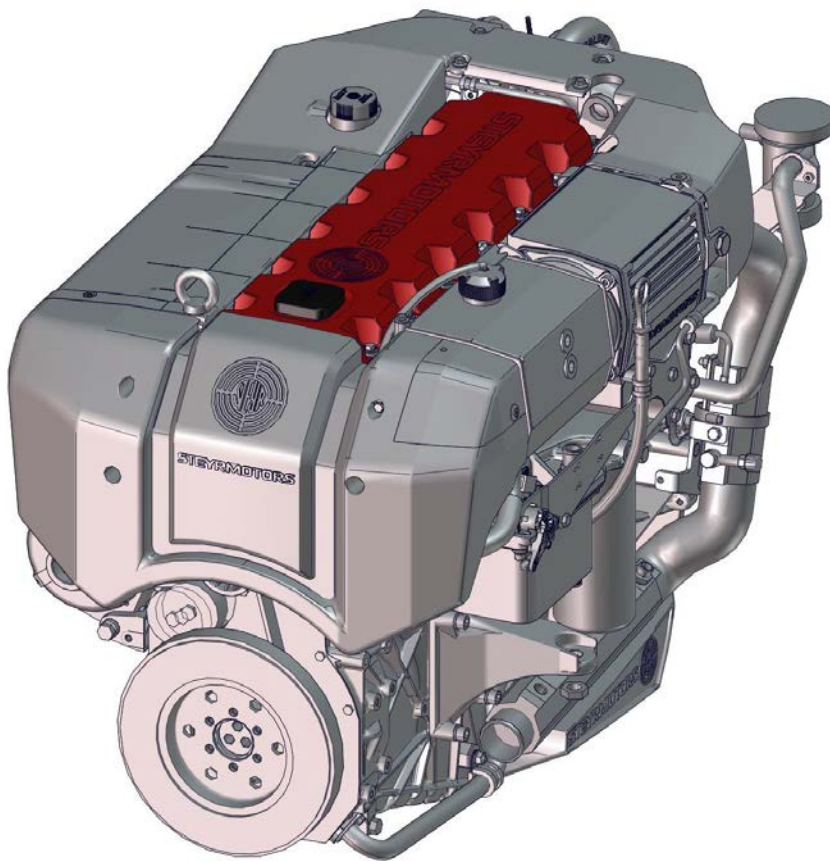

Document number	707245
Edition	04
Language	EN
Date	February 2026



## PREFACE

**Steyr Motors** develops high-performance diesel engines with modulated high pressure direct injection, especially for marine applications. **Steyr Motors** engines are designed to be adapted to various propulsion systems.

This **OPERATION MANUAL** provides technical data and know-how based on our experience in the diesel engine business. This manual intends to assist you in operating and maintaining the operational safety and reliability of the following engines:

# MARINE SE

4 Cylinder	6 Cylinder		
SE144E38	SE126E32	SE236E40	SE266S36
SE164E40	SE156E34	SE236S36	SE286E40
	SE186E38	SE266E40	SE306J38

To achieve continuous improvement with regard to the format and content of the information provided, we would like to hear from you.

We, therefore, would much appreciate your comments to the following questions:

- What mistakes have you noticed?
- What information was not in the manual?
- Suggestions for improvement in general?

Please address your comment to:

**ADR**

Steyr Motors AG  
Customer Service

Im Stadtgut B1  
4407 STEYR, AUSTRIA

**TEL**

+43/7252/222/52

**@**

[technical@steyr-motors.com](mailto:technical@steyr-motors.com)  
<https://www.steyr-motors.com>



Welcome aboard



Fig. 1.

Congratulations on your decision of choosing a **Steyr Motors** marine engine for your boat, and we hope you will enjoy it.

**Steyr Motors** develops high-speed diesel engines with two stage high-pressure fuel injection specifically for the marine environment. **Steyr Motors** marine engines are designed to be adapted to various propulsion systems.

To meet your expectations, please thoroughly study this manual for your new **Steyr Motors** marine engine to obtain information on its operation and handling in order to optimize the use of the various built-in functions.

With kind regards,  
**Steyr Motors AG**



Your Steyr Motors marine dealer

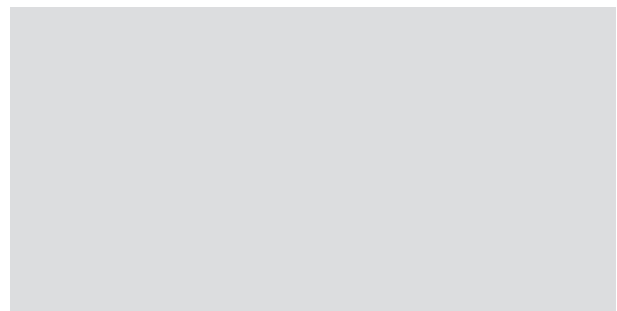

## TABLE OF CONTENTS

**SAFETY**

**GENERAL**

**01 OPERATION**

**02 MAINTENANCE**

**03 DEALERS ACTIVITIES**

**04 TRANSPORT AND STORAGE**

**WARRANTY**

### VERSIONS OF MANUAL

Version	Date	Modification
01	02.2021	new edition
02	04.2024	Changed section A 10 in chapter General Added instrument panel legend in chapter Operation Added subchapter “external mounted fuel sys- tem” in chapter Operation Changed section “U.S. EPA Emission control warranty” in chapter Warranty
03	10.2024	Changed SMB to SMO and Steyr Motors Be- triebs GmbH to Steyr Motors AG Removed fuel system from several views Updated fault codes in chapter Service-Code lists Updated subchapter external fuel system in chapter Operation Changed section W1 in chapter Warranty
04	02.2026	Pictograms adapted Table “General fault finding chart” updated Table “Trouble indication chart” updated Circuit diagrams replaced by references

---

## Table of Contents

<b>S</b>	<b>Safety .....</b>	<b>13</b>
<b>S 1</b>	<b>Safety precautions .....</b>	<b>14</b>
S 1.1	Introduction.....	14
<b>S 2</b>	<b>Customer's responsibility .....</b>	<b>17</b>
<b>S 3</b>	<b>Intended (appropriate) use .....</b>	<b>18</b>
<b>S 4</b>	<b>Personnel requirements .....</b>	<b>19</b>
S 4.1	Qualification.....	19
<b>S 5</b>	<b>Safety at work .....</b>	<b>20</b>
<b>S 6</b>	<b>Personal protective equipment .....</b>	<b>22</b>
<b>S 7</b>	<b>Noise.....</b>	<b>24</b>
<b>S 8</b>	<b>Exhaust gas .....</b>	<b>24</b>
<b>S 9</b>	<b>Operating and auxiliary material.....</b>	<b>25</b>
<b>S 10</b>	<b>Electrical energy .....</b>	<b>26</b>
<b>S 11</b>	<b>Maintenance.....</b>	<b>26</b>
<b>S 12</b>	<b>Behaviour in case of danger and accidents .....</b>	<b>27</b>
<b>S 13</b>	<b>Cleanliness at the workplace .....</b>	<b>28</b>
<b>S 14</b>	<b>Environmental protection .....</b>	<b>28</b>
<b>A</b>	<b>General remarks .....</b>	<b>31</b>
<b>A 1</b>	<b>General .....</b>	<b>31</b>
<b>A 2</b>	<b>Model and serial numbers .....</b>	<b>32</b>
A 2.1	Serial number 6 cylinder engine .....	32
A 2.2	Serial number 4 cylinder engine .....	33
A 2.3	Serial number gear box .....	33
<b>A 3</b>	<b>Documentation .....</b>	<b>34</b>
<b>A 4</b>	<b>Technical data and overview .....</b>	<b>35</b>
A 4.1	Technical data 6 cylinder engine (from year of manufacture 2021).....	35
A 4.2	Technical data 6 cylinder engine .....	36
A 4.3	Overview 6 cylinder engine .....	38
A 4.4	Technical data 4 cylinder engine .....	41
A 4.5	Overview 4 cylinder engine .....	42
<b>A 5</b>	<b>Product references, illustrations and specifications .....</b>	<b>45</b>
<b>A 6</b>	<b>Insurance.....</b>	<b>46</b>
<b>A 7</b>	<b>Stolen unit.....</b>	<b>46</b>

## Table of Contents

---

<b>A 8</b>	<b>Warranty Declaration, Emission Related Warranty .....</b>	<b>46</b>
A 8.1	Warranty registration approval .....	46
<b>A 9</b>	<b>Dealer service - maintenance .....</b>	<b>47</b>
<b>A 10</b>	<b>Repair service .....</b>	<b>48</b>
A 10.1	Replacement parts .....	48
<b>A 11</b>	<b>Before casting off .....</b>	<b>48</b>
<b>A 12</b>	<b>Engine submersion .....</b>	<b>49</b>
<b>A 13</b>	<b>Bottom painting .....</b>	<b>49</b>
<b>A 14</b>	<b>Boat bottom .....</b>	<b>50</b>
<b>A 15</b>	<b>Boating responsibilities .....</b>	<b>51</b>
A 15.1	Safety .....	51
<b>A 16</b>	<b>California proposition 65 warning .....</b>	<b>51</b>
<b>A 17</b>	<b>Symbols .....</b>	<b>52</b>
<b>B</b>	<b>Specifications .....</b>	<b>53</b>
<b>B 1</b>	<b>Fuel requirements .....</b>	<b>53</b>
B 1.1	How to select fuel .....	53
<b>B 2</b>	<b>Engine oil requirements .....</b>	<b>54</b>
<b>B 3</b>	<b>Engine coolant requirements .....</b>	<b>56</b>
<b>C</b>	<b>General information .....</b>	<b>57</b>
<b>C 1</b>	<b>Electronic engine management system .....</b>	<b>57</b>
<b>C 2</b>	<b>Diagnostic system .....</b>	<b>58</b>
<b>D</b>	<b>Quality guidelines for repair .....</b>	<b>59</b>
<b>D 1</b>	<b>Spare parts specification .....</b>	<b>59</b>
<b>D 2</b>	<b>Abbreviations .....</b>	<b>60</b>
<b>E</b>	<b>Disposal of automotive waste products .....</b>	<b>61</b>
<b>E 1</b>	<b>List of operating materials .....</b>	<b>61</b>
<b>E 2</b>	<b>Disposal of operating materials .....</b>	<b>61</b>
<b>F</b>	<b>Notes on safety .....</b>	<b>63</b>
<b>F 1</b>	<b>General notes on safety .....</b>	<b>63</b>
<b>F 2</b>	<b>Guidelines for damage prevention .....</b>	<b>63</b>
<b>F 3</b>	<b>Legal rules .....</b>	<b>63</b>
<b>F 4</b>	<b>Safety in the use of operating material .....</b>	<b>64</b>
<b>F 5</b>	<b>Measures in case of accidents .....</b>	<b>65</b>
<b>1</b>	<b>Operation .....</b>	<b>67</b>

---

<b>1.1</b>	<b>Before starting</b> .....	<b>68</b>
<b>1.2</b>	<b>Starting the engine (Key switch version)</b> .....	<b>70</b>
1.2.1	Stopping the engine (Key switch version) .....	71
<b>1.3</b>	<b>Starting the engine (Push button version)</b> .....	<b>72</b>
1.3.1	Stopping the engine (Push button version) .....	73
<b>1.4</b>	<b>Run in procedure after major overhaul</b> .....	<b>74</b>
1.4.1	Definitions.....	74
1.4.2	Procedure, work steps.....	74
<b>1.5</b>	<b>Engine break-in procedure</b> .....	<b>76</b>
1.5.1	First two hours .....	76
1.5.2	Next eight hours .....	77
1.5.3	Final ten hours of break-in.....	77
1.5.4	Operation after break-in.....	78
<b>1.6</b>	<b>Shifting</b> .....	<b>79</b>
<b>1.7</b>	<b>Remote control operating instructions</b> .....	<b>80</b>
<b>1.8</b>	<b>How to shift and control speed</b> .....	<b>82</b>
1.8.1	Fuel economy .....	82
1.8.2	Gear box - information.....	82
1.8.3	Fixed speed switch.....	82
<b>1.9</b>	<b>Instrument panel (Key switch version)</b> .....	<b>83</b>
1.9.1	Instrument panel legend.....	84
1.9.2	Instrument indication, normal operation (Key switch version) .....	85
<b>1.10</b>	<b>Instrument panel (Push button version)</b> .....	<b>86</b>
1.10.1	Instrument panel legend.....	87
1.10.2	Instrument indication, normal operation (Push button version) .....	88
<b>1.11</b>	<b>Emergency cut off switch (Lanyard)</b> .....	<b>89</b>
<b>1.12</b>	<b>Warning lights and audible alarm</b> .....	<b>90</b>
<b>1.13</b>	<b>Electronic engine control unit (ECU)</b> .....	<b>91</b>
<b>1.14</b>	<b>Diagnostic system</b> .....	<b>94</b>
<b>1.15</b>	<b>Propellers</b> .....	<b>95</b>
1.15.1	Twin installations .....	95
1.15.2	Optional propellers .....	95
1.15.3	Propellers .....	96
1.15.4	Propeller torque.....	97
1.15.5	Propeller care .....	97

---

## Table of Contents

---

<b>1.16</b>	<b>Water jet .....</b>	<b>97</b>
<b>1.17</b>	<b>Operating procedure for freezing temperatures.....</b>	<b>97</b>
<b>1.18</b>	<b>Salt water operation .....</b>	<b>98</b>
<b>1.19</b>	<b>High altitude operation .....</b>	<b>98</b>
<b>1.20</b>	<b>Fuel system.....</b>	<b>99</b>
1.20.1	Fuel pump.....	99
1.20.2	Fuel system checks .....	99
1.20.3	Fuel contamination .....	100
1.20.4	Fuel system (from year of manufacture June 2024).....	100
<b>1.21</b>	<b>Cooling system.....</b>	<b>103</b>
1.21.1	Function description: 6 cylinder engine .....	103
1.21.2	Function description: 4 cylinder engine .....	105
<b>1.22</b>	<b>Electrical equipment .....</b>	<b>106</b>
1.22.1	Alternator .....	106
1.22.2	Battery .....	107
1.22.3	Circuit breakers & fuses 6 cylinder engines .....	108
1.22.4	Circuit breakers & fuses 4 cylinder engines .....	109
1.22.5	Inversion switch (optional).....	110
1.22.6	Interrupt crankshaft housing ventilation (optional).....	110
1.22.7	Instrument panel.....	111
1.22.8	Dry operation .....	111
<b>1.23</b>	<b>Storage preservation procedure .....</b>	<b>111</b>
<b>1.24</b>	<b>Startup after storage .....</b>	<b>111</b>
<b>1.25</b>	<b>Fill fuel .....</b>	<b>112</b>
<b>1.26</b>	<b>Fill engine oil.....</b>	<b>113</b>
<b>1.27</b>	<b>Check and refill coolant.....</b>	<b>115</b>
<b>2</b>	<b>Maintenance and service .....</b>	<b>117</b>
<b>2.1</b>	<b>Foreword .....</b>	<b>117</b>
<b>2.2</b>	<b>Trouble check chart.....</b>	<b>118</b>
<b>2.3</b>	<b>General fault finding chart.....</b>	<b>121</b>
<b>2.4</b>	<b>Service and maintenance schedule.....</b>	<b>122</b>
<b>2.5</b>	<b>Trouble indication chart (from year of manufacture 2021) .....</b>	<b>128</b>
<b>2.6</b>	<b>Trouble indication chart (until year of manufacture 2020).....</b>	<b>129</b>
<b>2.7</b>	<b>Service stickers .....</b>	<b>130</b>
<b>2.8</b>	<b>Error indication on instrument panel .....</b>	<b>132</b>

---

<b>2.9</b>	<b>Service-code lists</b> .....	<b>138</b>
2.9.1	V30000.2H (valid for engines from year of manufacture 2021) .....	138
2.9.2	V50000.11B (valid for engines until year of manufacture 2020) .....	142
<b>2.10</b>	<b>Wiring diagram SE E-Box 12 V, 6 cyl. (standard)</b> .....	<b>146</b>
<b>2.18</b>	<b>Wiring harness SE 6 cyl.</b> .....	<b>147</b>
<b>2.19</b>	<b>Wiring diagram SE E-Box 12 V, 4 cyl. (standard)</b> .....	<b>148</b>
<b>2.23</b>	<b>Wiring harness SE 4 cyl.</b> .....	<b>149</b>
<b>2.24</b>	<b>Wiring diagram Instrument CAN Panel 12/24 V</b> .....	<b>150</b>
<b>3</b>	<b>Maintenance activities</b> .....	<b>151</b>
3.1	Check engine oil level .....	151
3.2	Refill engine oil .....	151
3.3	Oil level for power steering .....	152
3.4	Oil level for transmission .....	152
3.5	Check coolant (Closed cooling circuit) .....	153
3.6	Drain the raw water circuit of the engine .....	154
3.7	Check raw water connection .....	154
3.8	Drain the cooling water circuit of the engine .....	155
3.9	Anodes 6 cylinder engine .....	156
3.9.1	Cooling system anodes .....	156
3.9.2	Anti-corrosion anodes .....	156
3.10	Anodes 4 cylinder engine .....	158
3.10.1	Cooling system anodes .....	158
3.10.2	Anti-corrosion anodes .....	158
3.11	Air filter .....	160
3.12	Maintenance poly-v belt 6 cylinder engine .....	160
3.13	Maintenance poly-v belt 4 cylinder engine .....	160
3.14	Engine alignment .....	161
3.14.1	Engine alignment with AC-compressor .....	161
3.15	Propeller selection .....	162
3.16	Preparations for off-season storage .....	163
3.16.1	Start-up after storage .....	164
3.17	Logbook .....	165
<b>4</b>	<b>Transport and storage</b> .....	<b>169</b>
4.1	Transport inspection .....	170
4.2	Packing .....	171

---

## Table of Contents

---

4.2.1	Concerning packing.....	171
4.2.2	Handling packing materials .....	171
<b>4.3</b>	<b>Transport.....</b>	<b>172</b>
<b>4.4</b>	<b>Storage .....</b>	<b>174</b>
4.4.1	Storage conditions.....	174
4.4.2	Start-up after storage.....	175
<b>4.5</b>	<b>Extended storage preservation procedure .....</b>	<b>176</b>
4.5.1	Preservation .....	177
4.5.1.1	1 <sup>st</sup> Preservation procedure .....	177
4.5.2	2 <sup>nd</sup> Preservation .....	183
4.5.3	De-preservation .....	184
4.5.3.1	De-preservation .....	184
4.5.3.2	De-preservation procedure.....	185
<b>G</b>	<b>Operating and auxiliary materials .....</b>	<b>187</b>
<b>W</b>	<b>Warranty .....</b>	<b>189</b>
<b>W 1</b>	<b>STEYR MOTORS LIMITED ENGINE WARRANTY .....</b>	<b>189</b>
<b>W 2</b>	<b>U.S. EPA Emission control warranty (valid only on U.S.-flagged vessels) .....</b>	<b>200</b>

## S Safety

This manual contains certain information related to the personal safety of you as the operator, your passengers, bystanders and other persons.

**Steyr Motors AG** is concerned about your safety and the condition of your engine. The safety instructions will alert you to potential hazards associated with installing **Steyr Motors** engines.

This chapter provides an overview of all important safety aspects for optimal protection of personnel as well as safe and trouble-free operation. Inappropriate behaviour and insufficient knowledge of hazards during works may cause personal injury.

Non-observance of these safety instructions and safety regulations can result in considerable danger. In the description of works, such sources of danger are marked with one of the three following symbols:

---

### **DANGER**

**DANGER** indicates a hazardous situation which, if not avoided, will result in death or serious injury!

Possible consequences by non-observance.

▶ How to avoid injuries.

---

### **WARNING**

**WARNING** indicates a hazardous situation which, if not avoided, could result in death or serious injury!

Possible consequences by non-observance.

▶ How to avoid injuries.

---

### **CAUTION**

**CAUTION** indicates a hazardous situation which, if not avoided, could result in minor or moderate injury!

Possible consequences by non-observance.

▶ How to avoid injuries.

---

### **Property damage to the engine**

---

### **NOTICE**

NOTICE indicates a potentially hazardous situation, if not avoided, could result in damage to the engine.

▶ How to avoid damages.

---

### S 1 Safety precautions

#### S 1.1 Introduction

This operation manual contains the information you will need to operate the engine correctly. Check that you have the correct operation manual for your engine.

Read the book carefully before operating or servicing the engine. Incorrect operation or servicing of the engine could result in personal injury or material damage as well as damage to the engine itself. If you do not understand or are uncertain of any operation in this book, contact your dealer who can explain or demonstrate the procedure for you.

Before starting work on the engine, read the "Safety precautions" of this manual carefully.



Immobilize the engine by turning off the power supply to the engine at the main switch (switches/breakers) and lock it (them) in the OFF position before starting work. Set up a warning notice at the engine control point or helm.

As a general rule all service operations must be carried out with the engine stopped. However, certain adjustments require that the engine is running when they are carried out.

Approaching an engine which is operating is a safety risk. Loose clothing or long hair can fasten in rotating parts and cause serious personal injury. If working in proximity of an engine which is operating, careless movements or a dropped tool can result in personal injury.

Take care to avoid contact with hot surfaces (exhaust pipes, turbocharger, air intake pipe, start element etc.) and hot liquids in lines and hoses on an engine which is running or which has just been stopped. Reinstall all protective parts removed during service operations before starting the engine.



Check that the warning or information labels on the engine are always clearly visible. Replace labels which have been damaged or painted over.



Engines with turbocharger: Never start the engine without installing the air cleaner filter. The rotating compressor in the turbo can cause serious personal injury. Foreign objects entering the intake ducts can also cause mechanical damage.

Never use start spray products or similar when starting the engine. They may cause an explosion in the inlet manifold. Danger of personal injury.



Avoid opening the filler cap for engine coolant system (freshwater cooled engines) when the engine is still hot. Steam or hot coolant can spray out. Open the filler cap slowly and release the pressure in the system. Take great care if a cock, plug or engine coolant line must be removed from a hot engine. Steam or hot coolant can spray out in any direction.

Hot oil can cause burns. Avoid getting hot oil on the skin. Ensure that the lubrication system is not under pressure before carrying out any work. Never start or operate the engine with the oil filler cap removed, otherwise oil could be ejected.



Stop the engine and close the sea cock before carrying out operations on the engine cooling system.



Only start the engine in a well-ventilated area. If operating the engine in an enclosed area ensure that there is exhaust ventilation leading out of the engine compartment or workshop area to remove exhaust gases and crankcase ventilation emissions.

Always use protective glasses or goggles when carrying out work where there is a risk of splinters, grinding sparks, acid splashes or where other chemicals are used. The eyes are extremely sensitive, an injury could result in blindness!



Avoid getting oil on the skin! Repeated exposure to oil or exposure over a long period can result in the skin becoming dry. Irritation, dryness and eczema and other skin problems can then occur. Used oil is more dangerous than fresh oil from a health aspect. Use protective gloves and avoid oil soaked clothes and shop rags. Wash regularly, especially before eating. There are special skin creams which counteract drying out of the skin and make it easier to clean off dirt after work is completed.

Many chemicals used on the product (for example engine and transmission oils, glycol, gasoline and diesel oil), or chemicals used in the workshop (for example degreasing agents, paint and solvents) are dangerous to health. Read the instructions on the product packaging carefully! Always follow the safety precautions for the product (for example use of protective mask, glasses, gloves etc.). Make sure that other personnel are not exposed to hazardous chemicals (for chemicals released in the air). Ensure good ventilation in the work place. Follow the instructions provided when disposing of used or leftover chemicals.



Exercise extreme care when leak detecting on the fuel system and testing the fuel injector jets. Use eye protection. The jet from a fuel injector nozzle is under extremely high pressure and has great penetrative energy, so the fuel can penetrate deep into the body tissue and cause serious personal injury. Danger of blood poisoning.



All fuels and many chemical substances are flammable. Do not allow naked flame or sparks in the vicinity. Fuel, certain thinner products and hydrogen from batteries can be extremely flammable and explosive when mixed with air.

Smoking is not to be permitted in the vicinity!

Ensure that the work area is well ventilated and take the necessary safety precautions before starting welding or grinding work. Always ensure that there are fire extinguishers at hand when work is being carried out.



Ensure that rags soaked in oil or fuel and used fuel or oil filters are stored safely. Rags soaked in oil can spontaneously ignite under certain circumstances. Used fuel and oil filters are environmentally dangerous waste and must be deposited at an approved site for destruction together with used lubricating oil, contaminated fuel, paint remnants, solvent, degreasing agents and waste from washing parts.

Never expose a battery to naked flame or electrical sparks. Never smoke in proximity to the batteries. The batteries give off hydrogen gas during charging which when mixed with air can form an explosive gas -oxyhydrogen. This gas is easily ignited and highly volatile. Incorrect connection of the battery can cause a single spark which is sufficient to cause an explosion with resulting damage. Do not shift the connections when attempting to start the engine (spark risk) and do not lean over any of the batteries.



Always ensure that the Plus [+ (positive)] and Minus [- (negative)] battery leads are correctly installed on the corresponding terminal posts on the batteries. Incorrect installation can result in serious damage to the electrical equipment. Refer to the wiring diagrams.



Always use protective goggles when charging and handling the batteries. Battery electrolyte contains sulphuric acid which is highly corrosive. Should the battery electrolyte come into contact with unprotected skin wash off immediately using plenty of water and soap. If battery acid comes in contact with the eyes, immediately flush with plenty of water and obtain medical assistance at once.



Turn the engine off and turn off the power at the main switch(es) before carrying out work on the electrical system.

Clutch adjustments must be carried out with the engine stopped.

## S 2 Customer's responsibility

The engine is only to be used in the commercial field of usage. The owner of the engine is subject to the legal obligations for health and safety at work. In addition the operational safety instructions in this manual, the applicable safety, accident prevention and environmental regulations for the application must also be complied with. The following particularly apply:

- The owner must be informed about the applicable health and safety conditions and determine hazards arising from the special operating conditions at the usage location of the engine in a risk analysis. The owner must implement this in the form of operating instructions (e.g. service manual).
- The owner must check during the entire period of use of the engine whether the operating instructions he has produced comply with the current state of the regulations and adapt them if necessary.
- The owner must clearly regulate and specify the responsibilities for installation, operation, maintenance and cleaning.
- The owner must ensure that all employees involved with the engine have read and understood the operating instructions. He must also train the personnel and inform them about the dangers at regular intervals.
- The owner must provide the necessary protective equipment for the personnel.

The owner is also responsible that the engine is always in proper working condition. Therefore, strictly observe the following:

- The owner must ensure that the maintenance intervals specified in this manual are complied with.
- The owner must arrange for all safety equipment to be checked regularly for functionality and completeness.
- Explosive and easily flammable substances must always be kept away from the engine as the engine can become very hot during operation.
- Do not touch rotating parts while the engine is running.
- Only fill with fuel when the engine is switched off. Do not fill in the vicinity of naked flames or ignitable sparks, do not smoke and do not spill any fuel.
- This manual must be kept in the immediate vicinity of the engine and must be accessible at any time to all persons working on and with the engine.
- In the case of doubt, always contact **Steyr Motors AG** before starting the engine.
- The engine must only be operated if it is in proper working condition. The engine must be checked for intactness before every start-up.
- Only regular maintenance in accordance with the information in this manual maintains the operational readiness of the engine - otherwise loss of warranty.
- Only perform maintenance and cleaning work when the engine is out of operation.
- Strictly observe all the information in the manual.
- Always keep the engine in a good condition. Unauthorized modifications have a negative effect on functioning and/or safe operation as well as the service life.
- Any variations from the operating conditions that are defined in the technical data can result in premature failure of the engine or lead to major damage to property (e.g. by using the wrong fuel, etc).

### S 3 Intended (appropriate) use

The engine is designed and constructed exclusively for the intended purpose described here.

The engine is provided exclusively for the intended purpose which has been specified and tested by the manufacturer of the equipment in which the engine is installed:

- With connected exhaust system
- With connected cooling system
- With connected air intake
- No modifications to the vessel following a successful Vessel Acceptance Test by **Steyr Motors AG**
- Within the defined load profiles
- Within the permissible ambient temperatures
- Using permitted equipment (fuel, coolant, etc.)
- Within the specified vessel mass
- While observing the storage and storage conditions
- While maintaining maintenance intervals

Any other use is considered to be improper.

**Steyr Motors AG** accepts no liability for any dangers and damage resulting from this. The risk is born solely by the user.

The installation must be made so that all applicable safety regulations for the operation of diesel engines are complied with.

Proper use also includes compliance with all the information in this operation manual.

Any use beyond the intended use and/or other types of use is considered misuse and can result in dangerous situations.

---

## S 4 Personnel requirements

### S 4.1 Qualification

---

#### **WARNING**

##### **Danger of injury for unqualified personnel!**

Improper handling can result in severe personal injuries and/or material damage.

- ▶ Have all jobs carried out by qualified personnel only.
- 

The following qualifications are specified for different areas of activity listed in the manual:

- **Operator / User**  
has been instructed by the owner about the tasks assigned to him and possible dangers in the case of improper behaviour.
- **Service personnel**  
are persons who on the basis of their professional training by **Steyr Motors AG**, experience and knowledge of the relevant conditions can perform the work assigned to them using the operating, service and repair instructions and can recognise and avoid possible dangers themselves.
- Only persons who perform their tasks reliably are permitted as personnel. Persons whose reaction capability is impaired (e.g. through drugs, alcohol or medication) are not permitted.
- When selecting personnel, observe the age and occupational regulations applicable at the place of employment.

### S 5 Safety at work

---

#### Follow safety instructions

Read carefully all safety instructions in this manual as well as all warning labels on the engine.

- ▶ Keep the warning labels clean.
- ▶ Replace missing or damaged warning labels.
- ▶ Mark new components and spare parts with the currently valid warning labels.
- ▶ Replacement warning labels are available from the **Steyr Motors** dealer.

Familiarize yourself with the operation of the engine and the controls.

If you do not understand parts of this manual and need help, please contact your **Steyr Motors** dealer.

---



#### Risk of fire due to fuel and operating materials

Handle fuel with care: it is highly flammable.

- ▶ Always stop engine before refuelling engine.
  - ▶ Fill fuel tank outdoors.
  - ▶ Do not refuel the engine while smoking or when near open flames, sparks or other fire hazards.
  - ▶ Always clean up spilled fuel.
  - ▶ Store flammable fluids away from fire hazards.
  - ▶ Prevent fires by keeping engine clean of accumulated trash, grease and debris.
  - ▶ Do not store oily rags; they can ignite and burn spontaneously.
- 



---

### Cutting injuries by fan

Rotating cooling system fans can cause serious injury.

- ▶ Wear close fitting clothes.
- ▶ Stop engine and be sure fan is stopped before making adjustments or connections, or cleaning near the front of the engine.



---

### Avoid high-pressure fluids

Escaping fluid under pressure from high-pressure nozzles can penetrate the skin causing serious injury.

- ▶ Avoid the hazard by relieving pressure before disconnecting lines.
- ▶ Tighten all connections before applying pressure.
- ▶ Search for leaks with a piece of cardboard.
- ▶ Protect hands and body from high pressure fluids.
- ▶ Wear suitable personal protective equipment.
- ▶ If an accident occurs, see a doctor immediately.
- ▶ Any fluid injected into the skin must be surgically removed within a few hours or gangrene may result.



---

### Use proper lifting equipment

Lifting heavy components incorrectly can cause severe injury.

- ▶ Use only approved, inspected and adequately rated lifting equipment.
- ▶ Follow recommended procedure for removal and installation of components in the manual.



---

### Use only approved tools

Faulty or broken tools can result in serious injury. Makeshift tools and procedures can create safety hazards. Avoid bodily injury caused by slipping wrenches.



- ▶ When constructing tools, use proper quality materials and good workmanship.
  - ▶ Use only service parts meeting specifications.
  - ▶ For loosening and tightening hardware, use the correct size tools.
  - ▶ Only use spare parts according to specification.
- 

## S 6 Personal protective equipment

The personal protective equipment must comply with the national employee protection regulations.

The operator must make the appropriate personal protective equipment available for any person who performs work on the engine and instruct them to wear it. Wearing of personal protective equipment is required when working to minimize the health hazards.

- Always wear the protective equipment that is necessary for the respective task when working.
- Follow the instructions on personal protective equipment that are posted in the work area.

Generally wear for all kind of work:

---

### Protective clothing

is close fitting, with low resistance to tearing, with narrow sleeves and without protruding parts. It mainly provides protection against being entangled by moving engine parts.

Do not wear any rings and other jewellery.

---



---

### Safety boots

to protect against heavy parts falling down or slipping on slippery ground.

---



Personal protective equipment for special tasks. When performing special tasks it is necessary to wear personal protective equipment. This personal protective equipment will be separately specified in the chapters of this Manual. This special protective equipment is explained below.

---

### Ear defenders

to protect against hearing damage.

---



---

### Hard hat, helmet

to protect against parts and materials falling down and flying around.

---



---

### Protective gloves

to protect the hands against friction, graze, punctures or deep cuts as well as contact with hot surfaces.

---



---

### Safety goggles

to protect the eyes against parts flying around or squirts of fluids.

---



---

### Fine dust mask

to protect the airways against harmful dust.

---



### S 7 Noise

Noise can lead to an increased risk of accidents if the perception of acoustic signals, warning cries or danger announcing noise is affected by it.

Wear hearing protection (e.g. earmuffs or earplugs) at all workplaces with a sound pressure level of 85 dB(A).

Safe operation of the vessel requires the driver's full attention.

No headphones for listening to radio or music during operation.

---

#### Noise protection

Prolonged exposure to loud noise can cause impairment or loss of hearing.

In the case of loud noises, wear suitable noise protection (e.g. ear protectors or ear plugs).

---

### S 8 Exhaust gas

Risk due to exhaust gases! Engine exhaust fumes can result in sickness or death!

- ▶ The exhaust emissions need to be deflected from the control station of the engine. Ensure adequate ventilation.

Follow the law applicable to the site regulations!

Only carry out welding or grinding work on the engine, if it is expressly authorized. There is risk of fire or explosion!

---

## S 9 Operating and auxiliary material

Operating materials are

- Engine oil
- Fuel
- Coolant

Auxiliary materials are those substances which are required for maintenance and repair work (e.g. glue, paste, etc.)

### **Warning - Danger of poisoning and danger of skin rashes and allergies!**

Fuels (carcinogenic) and lubricants contain substances harmful to health and can result in severe poisoning and skin rashes or allergies.

- ▶ Observe the safety data sheet of the manufacturer of fuels and lubricants.
- ▶ Avoid spills of fuel and fog.
- ▶ In the case of inhalation, bring affected person into the open air immediately. Contact a doctor.
- ▶ Contact doctor immediately in the case of swallowing. Rinse mouth thoroughly with water.
- ▶ Avoid skin and eye contact.
- ▶ Wear protective gloves made of plastic or rubber during the work.
- ▶ In the case of contact with the skin or eyes, rinse immediately with a lot of water. Contact a doctor.
- ▶ Dispose of contamination in the working area properly and in accordance with environmental regulations.
- ▶ Fuels and lubricants must not get into the sewer system.
- ▶ Do not eat, drink or smoke when working.

---

### **Safe handling of auxiliary and operating materials.**

Direct contact with hazardous materials can cause serious injuries. Material Safety Data Sheets (MSDS) provide specific information about chemicals: physical and health hazards, safety precautions, and emergency procedures.

- ▶ Read Material Safety Data Sheets before starting work with hazardous chemicals (consult your dealer for safety data sheets for chemical products used with your engine).
-

### S 10 Electrical energy

Work on electrical equipment may only be carried out by a qualified electrician or by instructed persons under the direction and supervision of a qualified electrician in accordance with electrotechnical regulations.

Check cable (hoses) and screw connections regularly for leaks and externally visible damages. Repair damages immediately.

In addition to the general safety instructions, local safety instructions and guidelines must be observed and respected.

### S 11 Maintenance

---

#### Service engine safely

Loose clothing (e.g. necktie, scarf) or jewellery (e.g. necklace) can cause serious injury if these items were to get caught by moving parts.

- ▶ Tie long hair behind your head.
  - ▶ Do not wear a necktie, scarf, loose clothing or necklace.
  - ▶ Remove rings and other jewellery to prevent electrical shorts and entanglement in moving parts.
- 



---

#### Service cooling system safely

Explosive release of fluids from pressurized cooling system can cause serious burns.

- ▶ Shut off engine.
  - ▶ Only remove filler cap when cool enough to touch with bare hands.
  - ▶ Slowly loosen cap to first stop to relieve pressure before removing components.
- 



---

### Practice safe maintenance

- ▶ All work may only be carried out by trained personnel.
  - ▶ Understand service procedure before doing work.
  - ▶ Keep area clean and dry.
  - ▶ Never lubricate, service or adjust engine while it is moving.
  - ▶ Keep hands, feet and clothing from power-driven parts.
  - ▶ Securely support any engine elements that must be raised for service work.
  - ▶ Keep all parts in good condition and properly installed.
  - ▶ Repair damages immediately.
  - ▶ Replace worn or broken parts.
  - ▶ Remove any buildup of grease, oil or debris.
- 

## S 12 Behaviour in case of danger and accidents

---

### Prepare for emergencies

Preventive measures:

- ▶ Always be prepared for accidents or fire.
  - ▶ Keep first aid equipment (first aid kit, blankets etc.) and fire extinguishers ready at hand.
  - ▶ Keep emergency numbers for doctors, ambulance service, hospital, and fire department near your telephone.
  - ▶ Familiarise personnel with accident reporting, first aid and rescue equipment.
  - ▶ Keep access routes clear for rescue vehicles.
- 



### Actions in case of accidents

- Operate the EMERGENCY STOP button on the engine (if present) immediately.
- Initiate first aid actions.
- Rescue people from the danger zone.
- Inform the responsible person at the usage location.
- Notify the rescue services.
- Keep access routes clear for rescue vehicles.

### S 13 Cleanliness at the workplace

---

#### **Keep workplace and engine clean.**

Before starting a job:

- ▶ Clean work area and engine.
  - ▶ Make sure you have all necessary tools to do your job.
  - ▶ Have the right parts on hand.
  - ▶ Read all instructions thoroughly; do not attempt shortcuts. Unauthorized reconstruction and modification are not allowed.
- 

### S 14 Environmental protection

---



#### **Environment**

Significant environmental damage can occur, particularly from incorrect disposal, if environmentally hazardous operating materials are mishandled.

- ▶ Observe the safety data sheet from the manufacturer.
  - ▶ Dispose of waste properly.
  - ▶ Take immediate action if environmentally hazardous materials reach the environment. Inform the responsible local authorities about the damage in the case of doubt.
-

---

### Dispose of waste properly

Improperly disposing of waste can threaten the environment and ecology. Potentially harmful waste used with equipment includes such items as oil, fuel, coolant, brake fluid, filters and batteries.



- ▶ Use leakproof containers when draining fluids.
  - ▶ Do not use food or drink containers that could mislead people into drinking from them.
  - ▶ Do not pour waste onto the ground, down a drain, or into any water source.
  - ▶ Inquire on the proper way to recycle or dispose of waste from your local environmental or recycling centre, or from your dealer / **Steyr Motors AG**.
-



---

## A General remarks

### A 1 General

This manual is published by **Steyr Motors** with the main intention to provide information in form of technical data and know-how based on our experience in the marine diesel engine business, which will enable you, after thorough study to operate and check the engines on your boat; ensuring their operating safety, reliability and long service life.

#### **CE Conformity:**

Under regular maintenance, as described in the chapter 2 **Maintenance and service**, the exhaust gas emission levels adhere to the limits stipulated, for pleasure boat operation, throughout the lifetime of the engine.

#### **Limited Application (US only):**

Ship-owners or boat builders intending to purchase and install a **Steyr Motors** marine engine in a vessel which will be used in ECA (Emission Control Areas) and which are not excluded from IMO Tier III in accordance with Annex VI regulation 13.1.2, must contact the EPA and the US Coast Guard to request an exception from IMO Tier III in accordance with Annex VI Regulation 13.5.2.2 using engines with an EPA Tier 3 / IMO MARPOL 73/78 Tier II approval.

Regarding the Steyr Motors Limited Engine Warranty please refer to the **Steyr Motors** website:

<https://www.steyr-motors.com/>.

All warranty claims to be addressed to your local **Steyr Motors** marine dealer.

(We have to rely on your assistance however.) For a continuous improvement with regard to form and contents of the required information.

Your comments on the following questions would be much appreciated

- Which descriptions or terms are not understandable?
- Which enlargements or complements do you suggest?
- Where did content-related mistakes slip in?

Please address your comments and ideas to your **Steyr Motors** marine dealer.

## A 2 Model and serial numbers

The primary model and serial number is located on the engine as illustrated.

**These numbers are required for warranty claims and ordering parts.**

### A 2.1 Serial number 6 cylinder engine

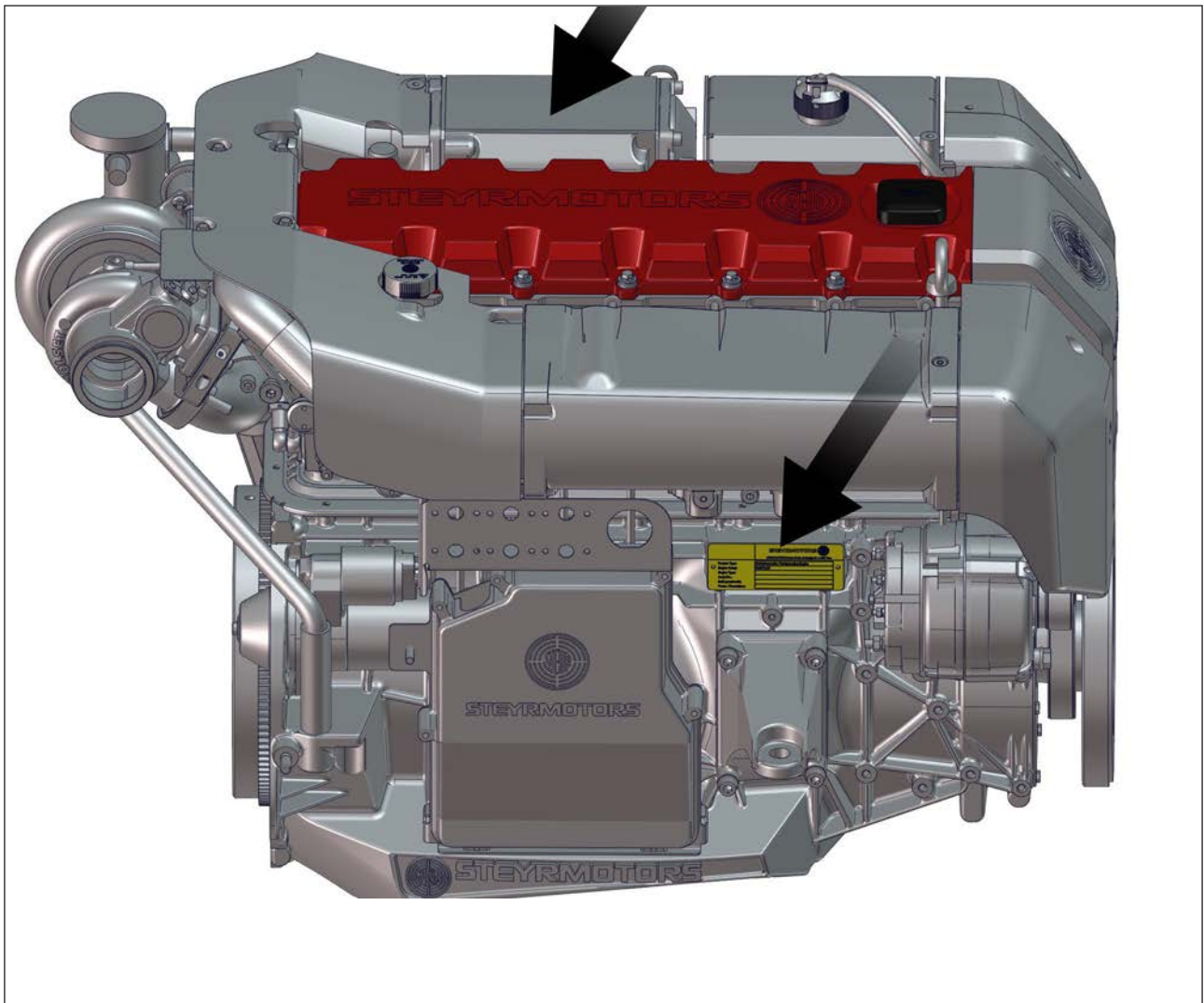

Fig. 2

## A 2.2 Serial number 4 cylinder engine

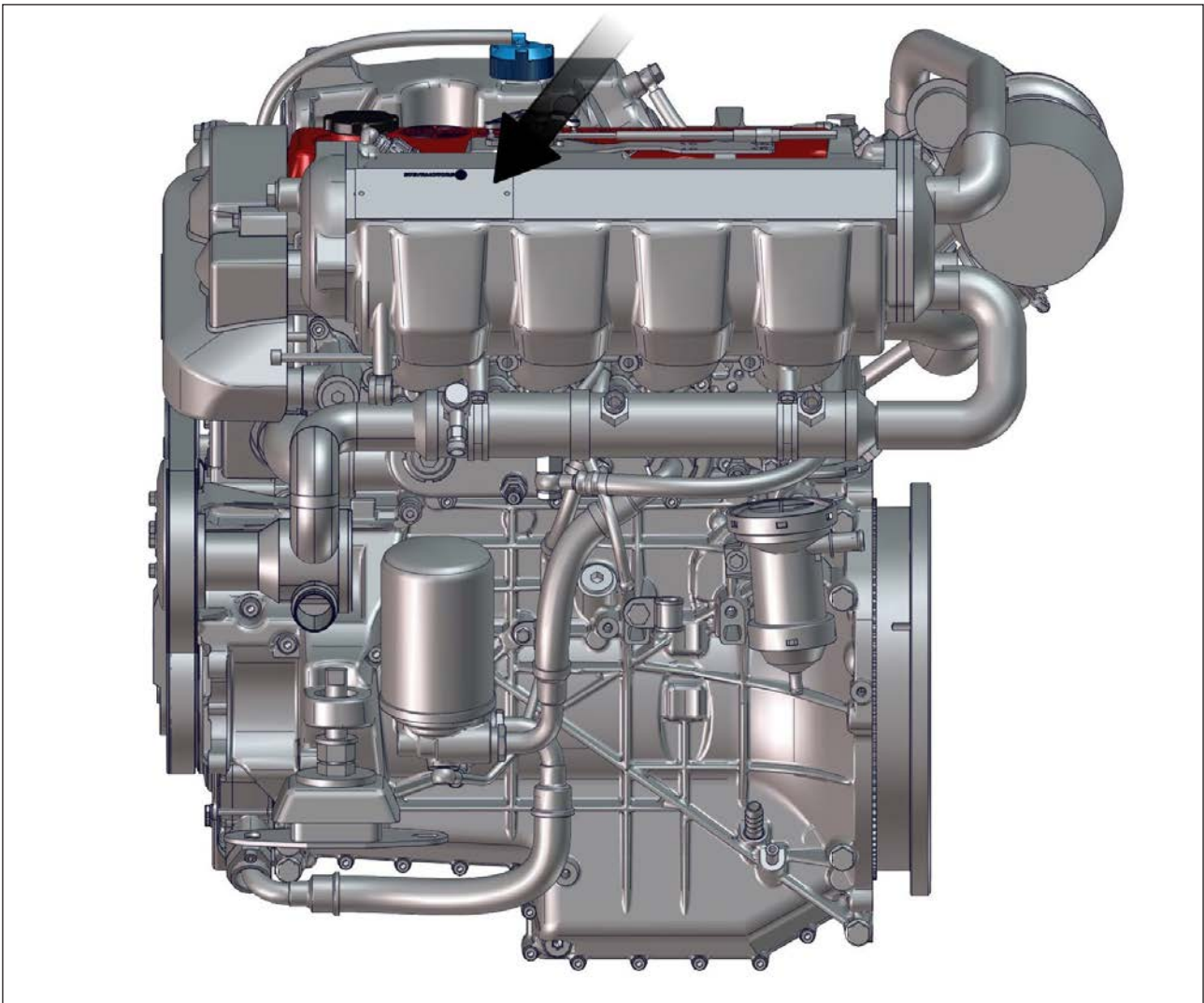

Fig. 3

## A 2.3 Serial number gear box

The model and serial number of the marine gear-box is located on the marine gearbox housing as illustrated.

### **NOTICE**

To obtain instructions regarding marine gear-box operation, refer to marine gearbox owners manual.

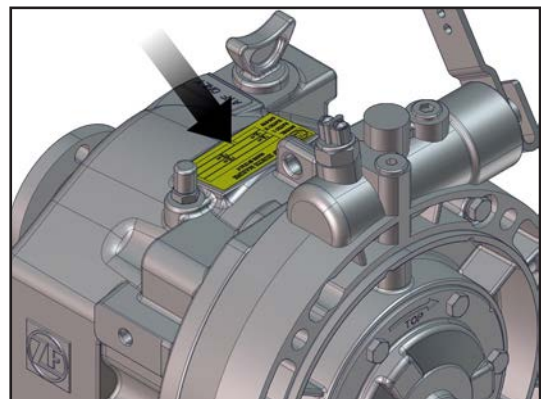

Fig. 4

### A 3 Documentation

The following documentation is available in English language on our website:

<https://www.steyr-motors.com>

Item	SMO Part number
Installation manual	P/N 707519
Operation, maintenance & warranty manual for MARINE	P/N 707245
Service manual for MARINE	P/N 707500
Spare parts catalogue SE126E32	P/N 707744
Spare parts catalogue SE156E34	P/N 704591
Spare parts catalogue SE186E38	P/N 707743
Spare parts catalogue SE236E40	P/N Z011844-0
Spare parts catalogue SE236S36	P/N Z011845-0
Spare parts catalogue SE266E40	P/N Z011846-0
Spare parts catalogue SE266S36	P/N Z011847-0
Spare parts catalogue SE286E40	P/N Z011848-0
Spare parts catalogue SE306J38	P/N Z011840-0
Spare parts catalogue SE144E38	P/N 500247
Spare parts catalogue SE164E40	P/N 500167
Optional equipment: SCC2	P/N 500156
Tool catalogue for Steyr Motors engines	P/N Z001002-1
User Manual Engine Diagnostic Tool EDT2	Z001080-0

---

**i** **Information**

Further detailed service information is permanently available for authorized SMO service partner via log-in to the SMO extranet.

---

## A 4 Technical data and overview

### A 4.1 Technical data 6 cylinder engine (from year of manufacture 2021)

Item	Unit	Specification		
		SE126E32	SE156E34	SE186E38
Type				
Displacement	cm <sup>3</sup>	3200		
Cylinder bore	mm	85		
Stroke	mm	94		
Rated power	kW	88	113	129
Aspiration		TCA		
Manifold absolute pressure at rated power	mbar	2100	2445	2640
Number of cylinders		6		
Numbering of cylinders		1 <sup>st</sup> at timing belt side		
Firing order		1 - 5 - 3 - 6 - 2 - 4		
Sense of rotation		Clockwise		
Compression ratio		$\epsilon = 17.0$		
Rated speed	rpm	3200	3400	3800
Max. torque	Nm	330	400	420
Max. torque speed	rpm	2050 - 2550	2300 - 2550	2300 - 2800
Idle speed	rpm	630		
Injection		Unit injector system, two-stage, high pressure with electronically controlled injection quantity		
Fuel specification		Diesel according to EN 590		
Fuel cons. at rated power	kg/h	22.2	27.2	31.5
Pre and main fuel filter		Refer to <b>Spare parts catalogue</b>		
Fuel filter location		Pressure sided		
Dry weight	kg	340		
Air filter		Refer to <b>Spare parts catalogue</b>		
Oil filling quantity	lt	17		
Oil filter		Refer to <b>Spare parts catalogue</b>		
Oil specification		SAE 10W-40 ACEA: E6, E7 API: CI-4, CH-4, CG-4, CF-4, CF		
Engine oil and oil filter change intervals		Refer to <b>Service and maintenance schedule</b>		
Cooling system		Dual cooling circuit; thermostat-controlled, pressurized cooling circuit; circulating pump with heat exchanger on engine; governor pump, external raw water circuit to heat exchange		
Coolant		Steyr Motors engine coolant – 40 °C P/No. 500831, ready mixed		
Coolant water quantity	lt	15.5		
Max. engine cooling raw water outlet temp.	°C	85		
Max. engine coolant outlet temp.	°C	105		
Max. exhaust back pressure	mbar	150		
Back pressure tolerance	mbar	+ 0 / - 50		

## General

### A 4.2 Technical data 6 cylinder engine

Item	Unit	Specification		
		SE236E40	SE236S36	SE266E40
Type				
Displacement	cm <sup>3</sup>	3200		
Cylinder bore	mm	85		
Stroke	mm	94		
Rated power	kW	170	170	190
Aspiration		TCA		
Manifold absolute pressure at rated power	mbar	2825	2590	2895
Number of cylinders		6		
Numbering of cylinders		1 <sup>st</sup> at timing belt side		
Firing order		1 - 5 - 3 - 6 - 2 - 4		
Sense of rotation		Clockwise		
Compression ratio		$\epsilon = 17.0$		
Rated speed	rpm	4000	3600	4000
Max. torque	Nm	470	540	530
Max. torque speed	rpm	2550-3300	1800-2550	2550-3050
Idle speed	rpm	630		
Injection		Unit injector system, two-stage, high pressure with electronically controlled injection quantity		
Fuel specification		Diesel according to EN 590		
Fuel cons. at rated power	kg/h	42.4	41	47.2
Pre and main fuel filter		Refer to spare part catalogue		
Fuel filter location		Pressure sided		
Dry weight	kg	340		
Air filter		Refer to spare part catalogue		
Oil filling quantity	lt	17		
Oil filter		Refer to spare part catalogue		
Oil specification		SAE 10W-40 ACEA: E6, E7 API: CI-4, CH-4, CG-4, CF-4, CF		
Engine oil and oil filter change intervals		Refer to <b>Service and maintenance schedule</b>		
Cooling system		Dual cooling circuit; thermostat-controlled, pressurized cooling circuit; circulating pump with heat exchanger on engine; governor pump, external raw water circuit to heat exchange		
Coolant		Steyr Motors engine coolant – 40 °C P/No. 500831, ready mixed		
Coolant water quantity	lt	15.5		
Max. engine cooling raw water outlet temp.	°C	85		
Max. engine coolant outlet temp.	°C	105		
Max. exhaust back pressure	mbar	150		
Back pressure tolerance	mbar	+ 0 / – 50		

Item	Unit	Specification		
		SE266S36	SE286E40	SE306J38
Type				
Displacement	cm <sup>3</sup>	3200		
Cylinder bore	mm	85		
Stroke	mm	94		
Rated power	kW	190	205	215
Aspiration		TCA		
Manifold absolute pressure at rated power	mbar	2810	3080	3175
Number of cylinders		6		
Numbering of cylinders		1 <sup>st</sup> at timing belt side		
Firing order		1 - 5 - 3 - 6 - 2 - 4		
Sense of rotation		Clockwise		
Compression ratio		$\varepsilon = 17.0$		
Rated speed	rpm	3600	4000	3800
Max. torque	Nm	600	570	588
Max. torque speed	rpm	1800-2300	2550-3300	3300
Idle speed	rpm	630		
Injection		Unit injector system, two-stage, high pressure with electronically controlled injection quantity		
Fuel specification		Diesel according to EN 590		
Fuel cons. at rated power	kg/h	46.1	50.3	51.9
Pre and main fuel filter		Refer to spare part catalogue		
Fuel filter location		Pressure sided		
Dry weight	kg	340		
Air filter		Refer to spare part catalogue		
Oil filling quantity	lt	17		
Oil filter		Refer to spare part catalogue		
Oil specification		SAE 10W-40 ACEA: E6, E7 API: CI-4, CH-4, CG-4, CF-4, CF		
Engine oil and oil filter change intervals		Refer to <b>Service and maintenance schedule</b>		
Cooling system		Dual cooling circuit; thermostat-controlled, pressurized cooling circuit; circulating pump with heat exchanger on engine; governor pump, external raw water circuit to heat exchange		
Coolant		Steyr Motors engine coolant – 40 °C P/No. 500831, ready mixed		
Coolant water quantity	lt	15.5		
Max. engine cooling raw water outlet temp.	°C	85		
Max. engine coolant outlet temp.	°C	105		
Max. exhaust back pressure	mbar	150		
Back pressure tolerance	mbar	+ 0 / – 50		

A 4.3 Overview 6 cylinder engine

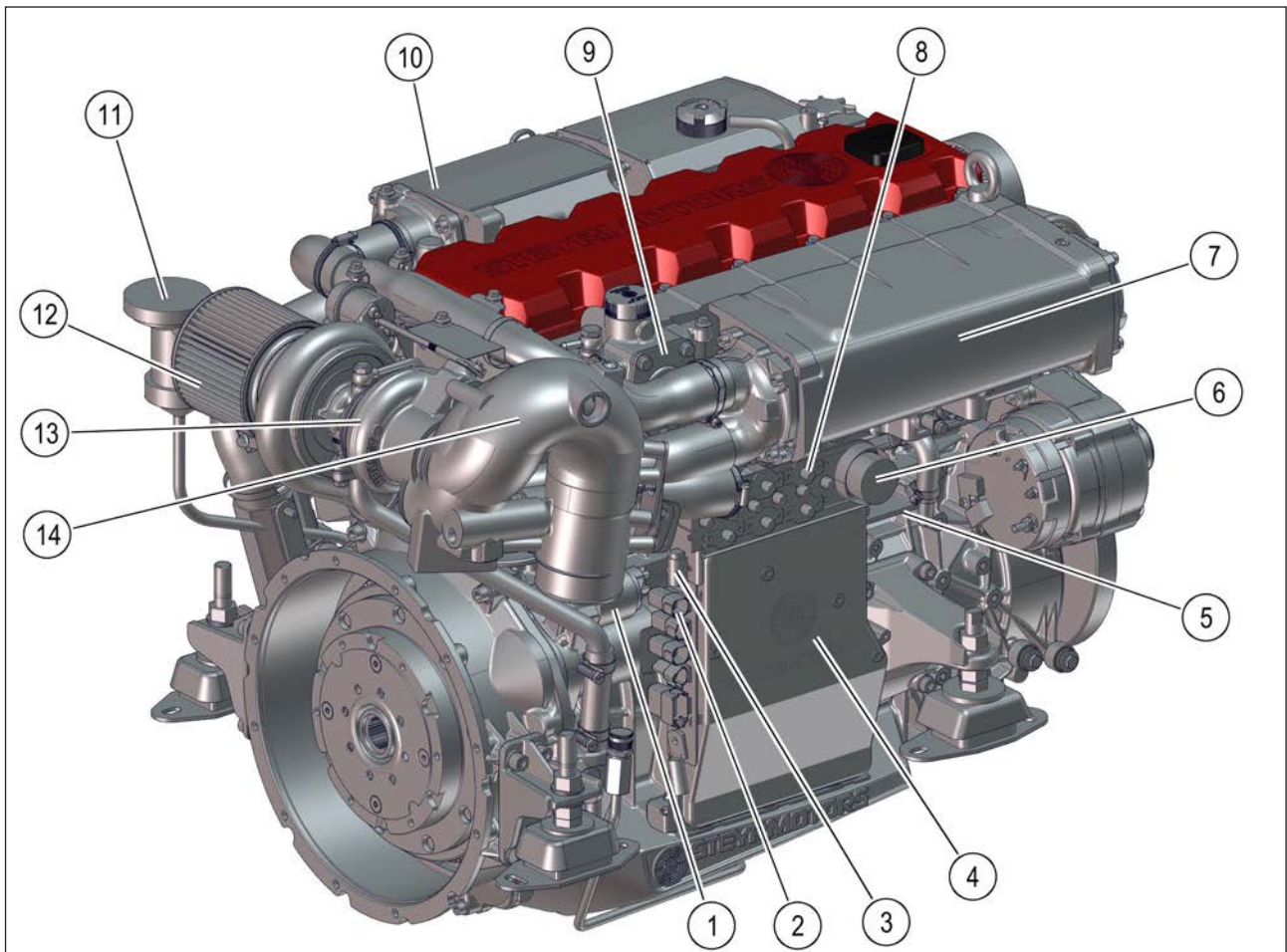

Fig. 5

Pos.	Description	Pos.	Description
1	Starter motor	8	Fuses (Circuit breakers)
2	Diagnostic outlet	9	Thermostat housing
3	Inversion switch	10	Inter cooler
4	Engine control unit (ECU) / relais	11	Oil separator
5	Model and serial number	12	Air filter
6	Connector instrument panel	13	Turbo charger
7	Heat exchanger	14	Exhaust elbow

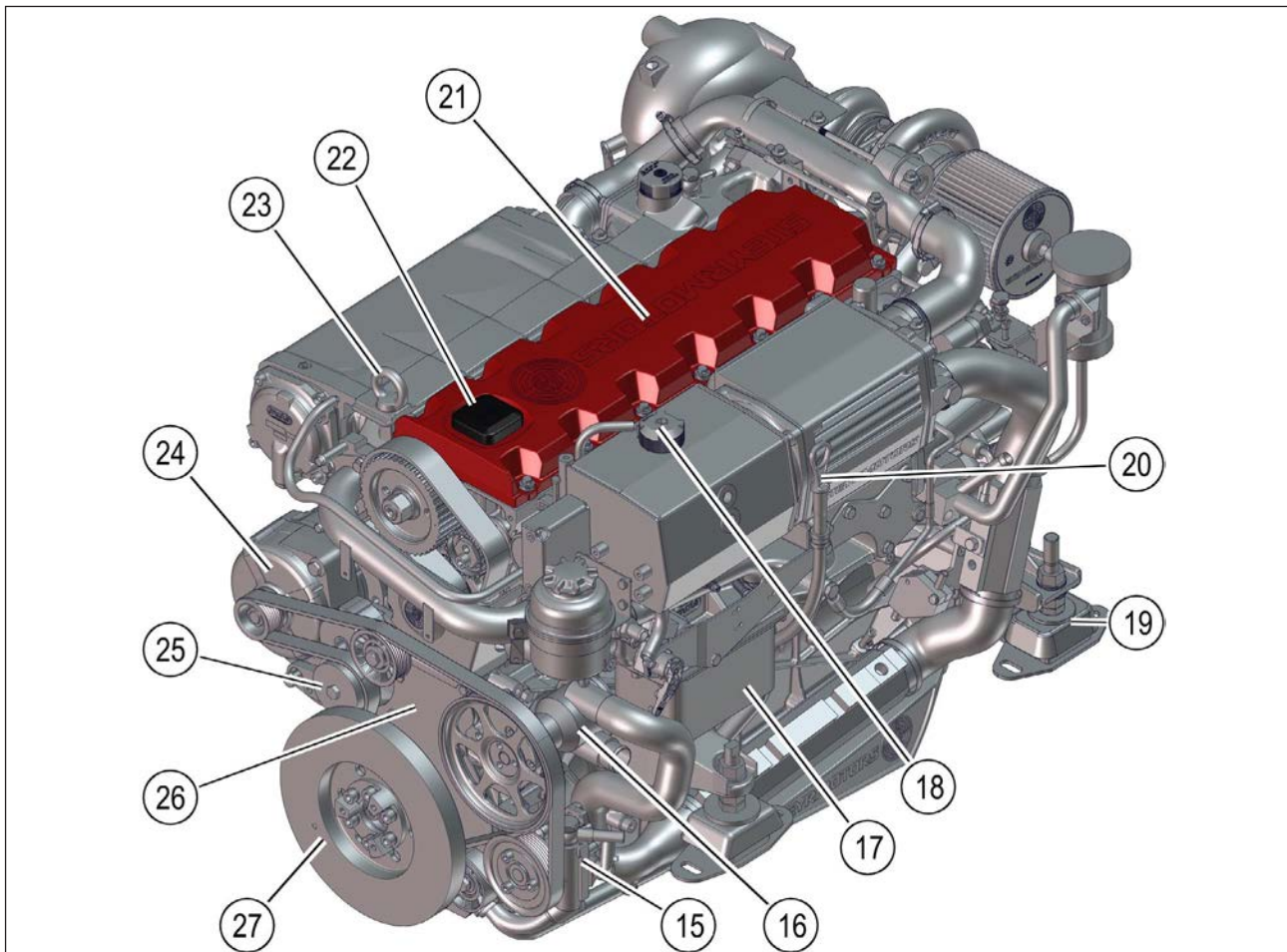

Fig. 6

Pos.	Description
15	Hydraulic pump
16	Raw water pump
17	Oil cooler
18	Cooler cap
19	Engine mount
20	Oil dipstick
21	Camshaft housing cover

Pos.	Description
22	Engine oil filler cap
23	Engine lifting eye
24	Alternator
25	Poly-v belt tensioner
26	Cover timing belt
27	Vibration damper

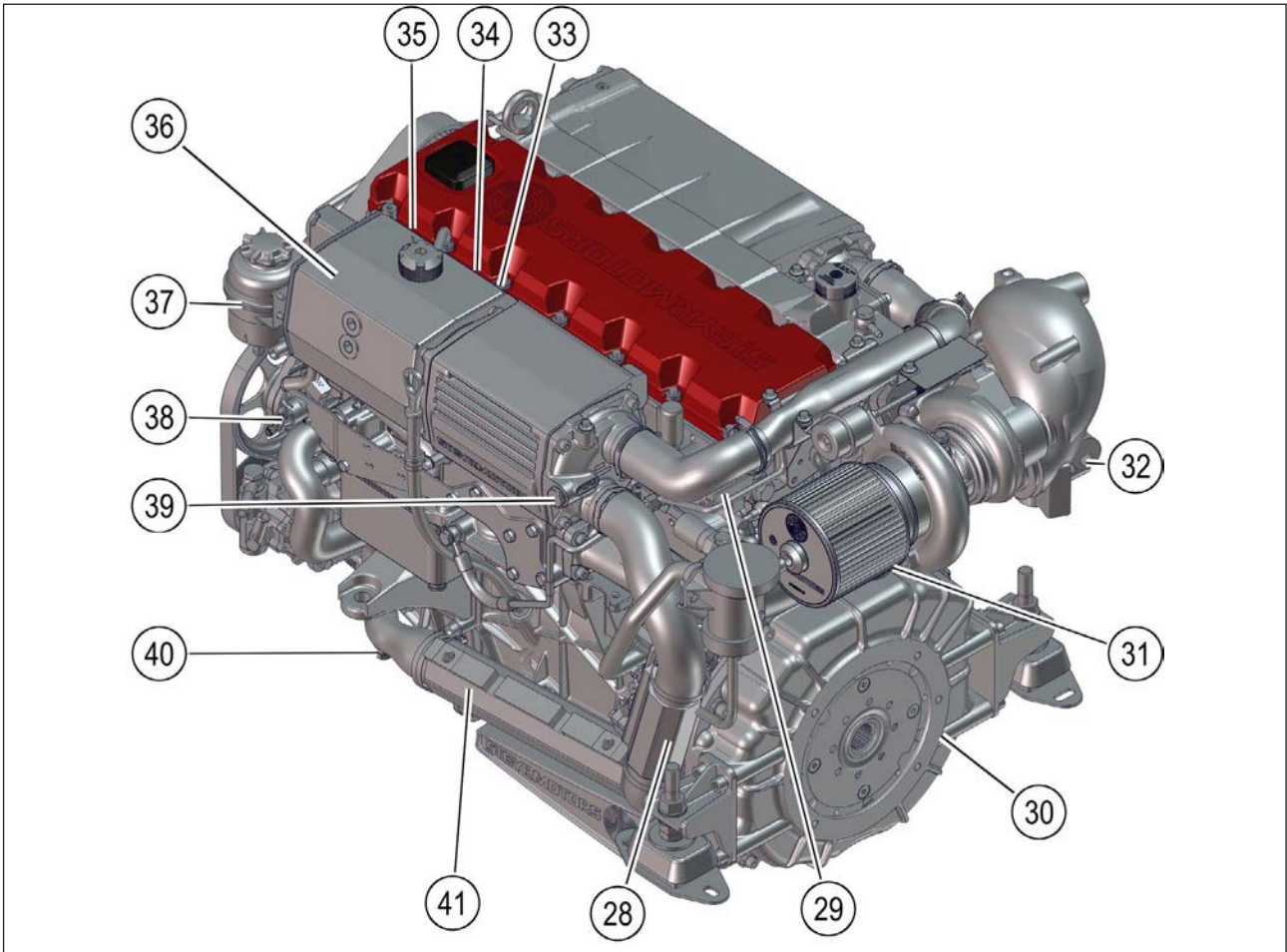

Fig. 7

Pos.	Description
28	Fuel cooler
29	Injection timing position sensor
30	Flywheel housing
31	Oil pressure sensor
32	Zinc anode
33	Charge air temperature sensor
34	Manifold absolute pressure sensor

Pos.	Description
35	Rack position sensor
36	Coolant expansion tank
37	Hydraulic oil tank
38	Potentiometer accelerator
39	Zinc anode
40	Raw water drain plug
41	Hydraulic oil cooler

## A 4.4 Technical data 4 cylinder engine

Item	Unit	Specification	
		SE144E38	SE164E40
Type			
Displacement	cm <sup>3</sup>	2133	
Cylinder bore	mm	85	
Stroke	mm	94	
Rated power	kW	106	118
Aspiration		TCA	
Manifold absolute pressure at rated power	mbar	2575	2815
Number of cylinders		4	
Numbering of cylinders		1 <sup>st</sup> at timing belt side	
Firing order		1 - 3 - 4 - 2	
Sense of rotation		Clockwise	
Compression ratio		$\varepsilon = 17.0$	
Rated speed	rpm	3800	4000
Max. torque	Nm	320	330
Max. torque speed	rpm	2300	2300
Idle speed	rpm	750	
Injection		Unit injector system, two-stage, high pressure with electronically controlled injection quantity	
Fuel specification		Diesel according to EN 590	
Fuel cons. at rated power	kg/h	27.1	29.5
Pre and main fuel filter		Refer to spare part catalogue	
Fuel filter location		Suction sided	
Dry weight	kg	263	
Air filter		Refer to spare part catalogue	
Oil filling quantity	lt	8.75	
Oil filter		Refer to spare part catalogue	
Oil specification		SAE 10W-40 ACEA: E6, E7 API: CI-4, CH-4, CG-4, CF-4, CF	
Engine oil and oil filter change intervals		Refer to <b>Service and maintenance schedule</b>	
Cooling system		Dual cooling circuit; thermostat-controlled, pressurized cooling circuit; circulating pump with heat exchanger on engine; governor pump, external raw water circuit to heat exchange	
Coolant		Steyr Motors engine coolant – 40 °C P/No. 500831, ready mixed	
Coolant water quantity	lt	10.7	
Max. engine cooling raw water outlet temp.	°C	85	
Max. engine coolant outlet temp.	°C	105	
Max. exhaust back pressure	mbar	150	
Back pressure tolerance	mbar	+ 0 / – 50	

A 4.5 Overview 4 cylinder engine

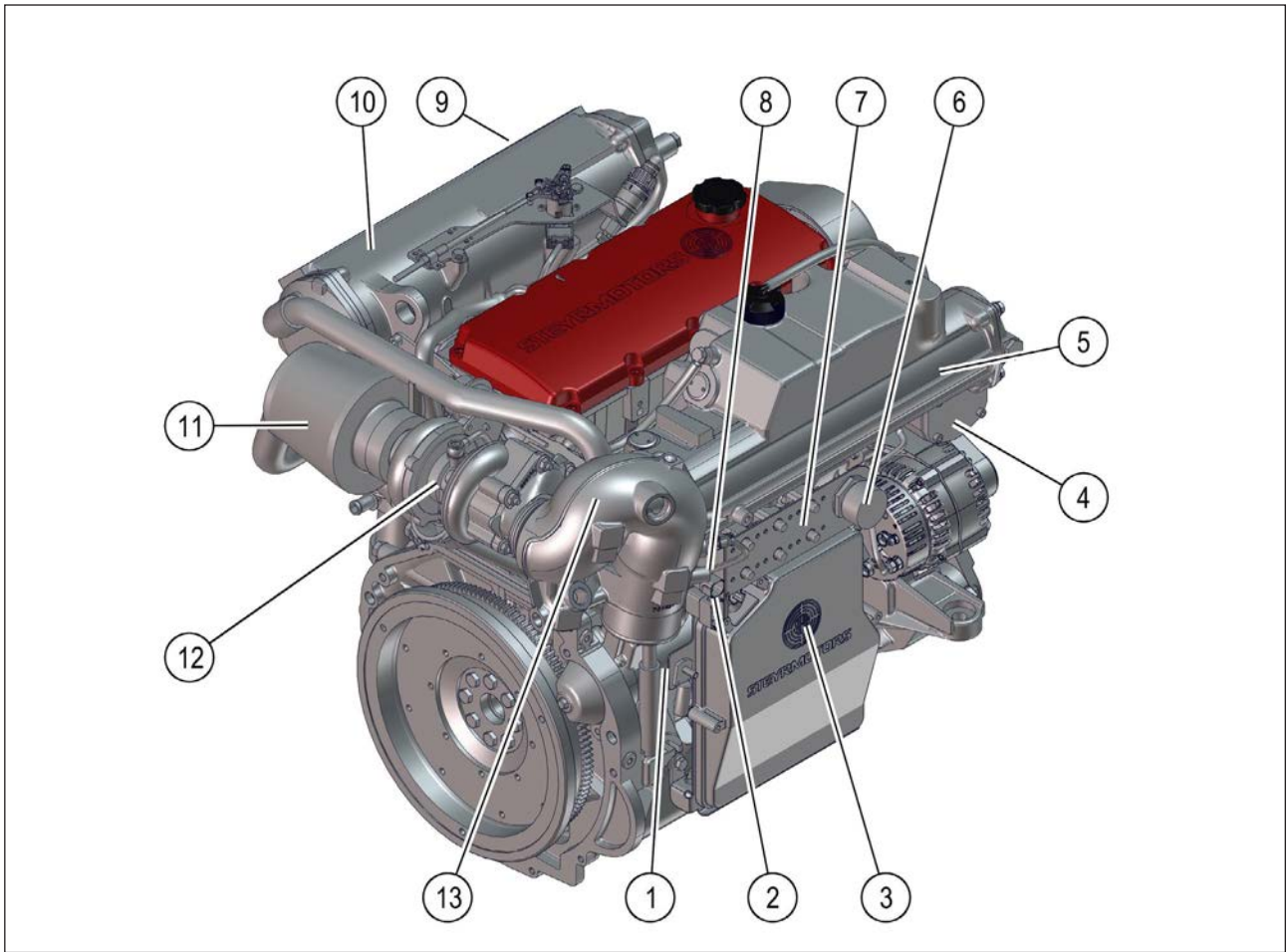

Fig. 8

Pos.	Description	Pos.	Description
1	Starter motor	8	Inversion switch
2	Diagnostic outlet	9	Model and serial number
3	Engine control unit (ECU) / relais	10	Intercooler
4	Thermostat housing	11	Air filter
5	Heat exchanger	12	Turbo charger
6	Connector instrument panel	13	Exhaust elbow
7	Fuses (Circuit breakers)		

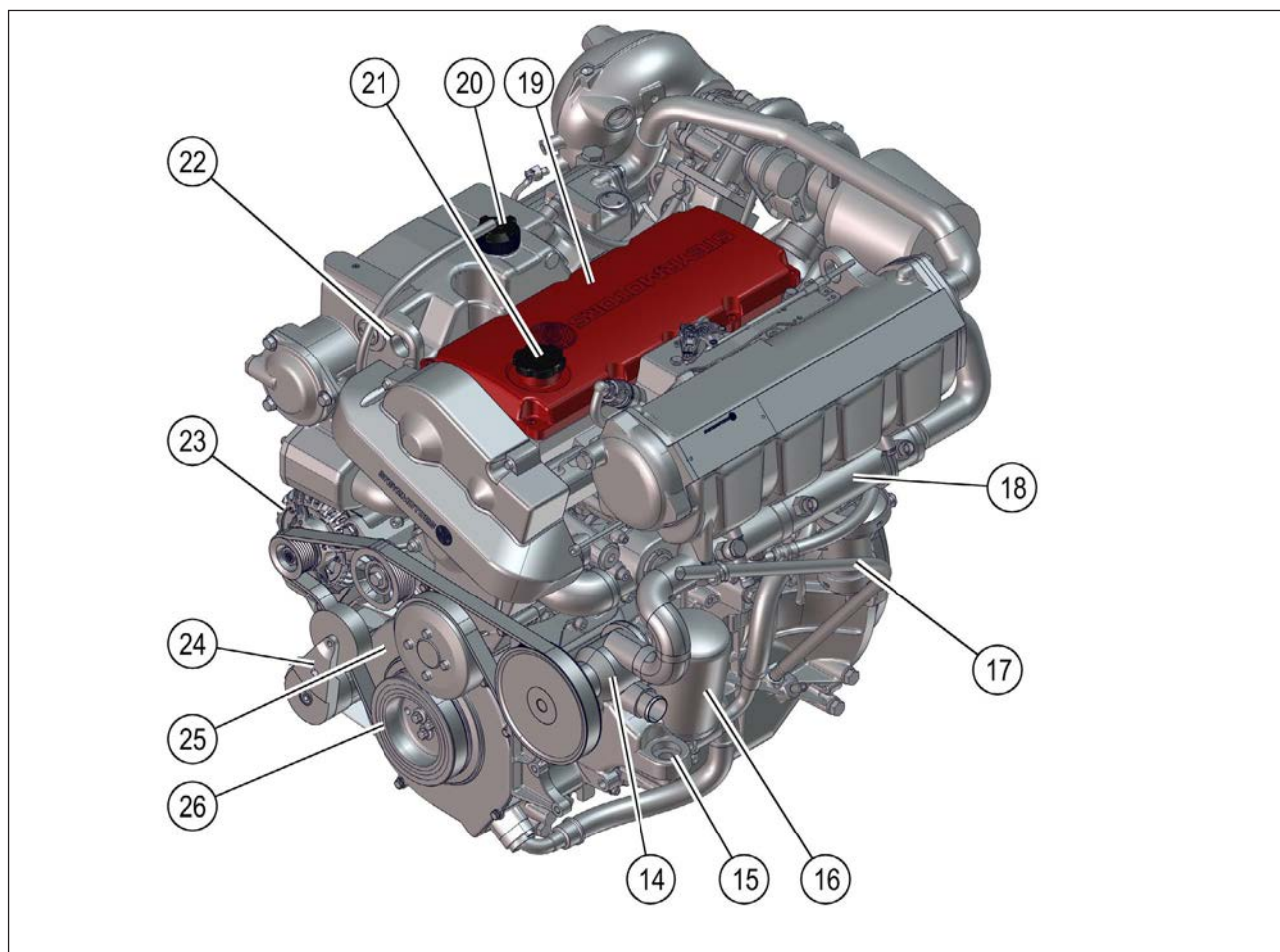

Fig. 9

Pos.	Description
14	Raw water pump
15	Engine mount
16	Oil filter
17	Oil dipstick
18	Tandem cooler, fuel - hydraulic oil
19	Camshaft housing cover
20	Cooler cap

Pos.	Description
21	Engine oil filler cap
22	Engine lifting eye
23	Alternator
24	Poly-v belt tensioner
25	Cover timing belt
26	Vibration damper

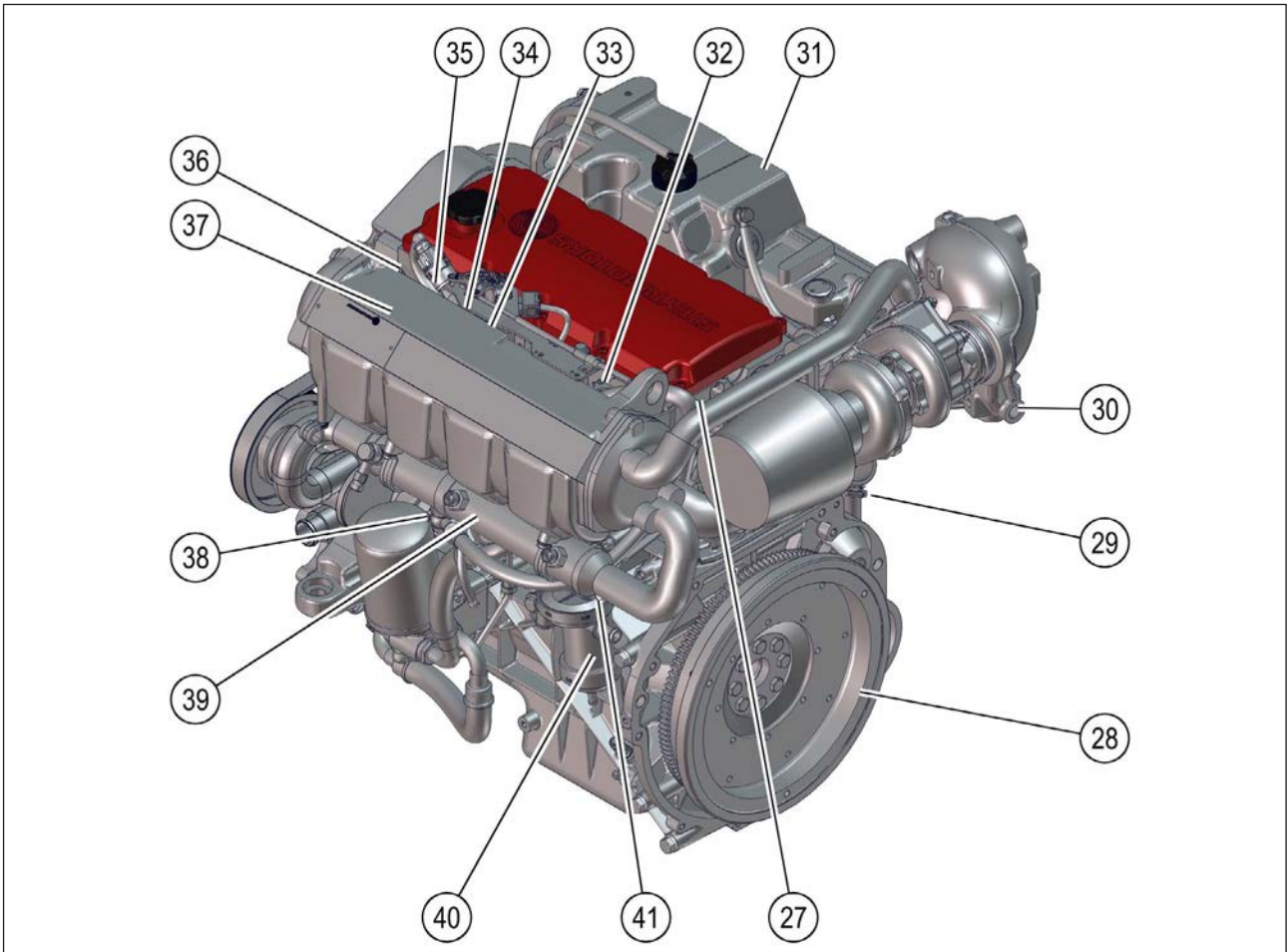

Fig. 10

Pos.	Description
27	Injection timing position sensor
28	Flywheel
29	Oil pressure sensor
30	Zinc anode
31	Coolant expansion tank
32	Injection timing device
33	Charge air temperature sensor
34	Potentiometer accelerator

Pos.	Description
35	Manifold absolute pressure sensor
36	Rack position sensor
37	Intercooler
38	Engine coolant drain plug
39	Tandem cooler, fuel - hydraulic oil
40	Oil separator
41	Raw water drain plug

## A 5 Product references, illustrations and specifications

When reference is made in this manual to a brand name, number, product or specific tool, an equivalent product may be used in place of the product referred to unless specifically stated otherwise. Equivalent products which are used must meet all current local regulations and standards to avoid hazards.

Some countries may apply additional internal regulation. Please follow their advices appropriately, example:

Austria		Bundesamt für Schifffahrt
England	LR =	Lloyds Register of Shipping
Finland		Navigation Office
France	BV =	Bureau Veritas
Germany		DNV GL Group
Italy	RINA =	Registro Italiano Navale
Norway		DNV GL Group
Sweden		Navigation Office
USA	ABYC =	American Boat Yacht Council
USA	NMMA =	National Marine Manufacturers Association
USA	USCG =	United States Coast Guard

All information, illustrations and specifications contained in this manual are based on the latest product information available at the time of printing. **Steyr Motors AG** reserves the right to make changes at any time, without notice, to specifications and models and also to discontinue models, as well as the right to change specifications or parts at any time without incurring any obligation to equip same on models manufactured prior to date of such change.

Continual accuracy of this manual cannot be guaranteed.

All illustrations used in this manual may not depict actual models or equipment and are intended as representative views for reference only.

### A 6 Insurance

Insurance on your **Steyr Motors** marine engine and boat should be obtained as soon as practical for protection against loss by fire, theft, etc. Consult your local insurance agent.

### A 7 Stolen unit

The model and serial numbers on your engine are important for you. As to the location of these important numbers, refer to model and serial numbers in the section technical data.

Record each of these numbers in the spaces provided at the end of this manual and on a separate sheet. Store the separate sheet in a safe place other than your boat.

In case of theft, report the model and serial numbers to your local authorities and your insurance agent.

### A 8 Warranty Declaration, Emission Related Warranty

The current version of the **Steyr Motors** warranty declaration and the emission-related warranty can be found under the following link on the homepage of **Steyr Motors AG**:  
<https://www.steyr-motors.com>.

#### A 8.1 Warranty registration approval

When you purchased your boat, your dealer was obliged to issue a warranty registration approval for your **Steyr Motors** marine engine.

This warranty registration approval gives proof and is to be submitted in case of warranty claims. Your **Steyr Motors** marine dealer is also obliged to complete the warranty registration approval.

Required tests and measurements are to be carried out from your **Steyr Motors** marine dealer and sent to **Steyr Motors AG** for approval of warranty registration.

## A 9 Dealer service - maintenance

---

### ***NOTICE***

Please do not forget to have confirmed in your manual that the installation and maintenance have been carried out in accordance with the guidelines.

---

This is also an opportunity to clarify with your **Steyr Motors** marine dealer possible questions that arise during the first running hours on your boat, and to establish a service and maintenance routine.

Services will be performed by **Steyr Motors** marine dealers at local rates.

Costs for service material has to be paid by the owner.

## A 10 Repair service

All repair works on your **Steyr Motors** marine engine should be carried out by a licensed **Steyr Motors** marine dealer with his professional knowledge, trained staff and special-purpose tools to solve all occurring problems. Preferably, all work on your **Steyr Motors** marine engine should be carried out by the **Steyr Motors** marine dealer that sold the equipment to you - he knows you and the equipment.

If problems occur during a trip, **Steyr Motors** recommends bringing your engine to the next **Steyr Motors** marine dealer. Information on dealers and distributors can be found at the end of this manual.

### A 10.1 Replacement parts

Your **Steyr Motors** marine engine was designed to operate in a marine environment. **Steyr Motors** recommends using parts supplied or approved by **Steyr Motors** for repair, replacement, or maintenance, to ensure maximum compliance and safety. Parts not supplied or approved by **Steyr Motors** may be of questionable quality and should only be used if equivalent.

## A 11 Before casting off

Check the weather report, wind and water conditions. Tell someone where you are going to and when you expect to arrive or return.

### Recommended minimum on-board tools

- Screwdriver set
- Metric socket set
- Metric Allen key set
- Metric spanner set
- Long nose pliers
- Lubrication oil spray
- 12-volt pilot lamp
- Flashlight
- Insulating tape
- Sharp knife

### Recommended minimum on-board spare parts

- Propeller and small parts for propeller mounting
- Fuel filter (pre- & fine filter)
- Impeller for raw water pump
- Fuses
- Bulbs
- Sealing compound

These lists represent a suggested **MINIMUM**, and are not intended to cover all boats or possible boating conditions.

---

## A 12 Engine submersion

Remove engine from water as quickly as possible and contact your local **Steyr Motors** marine dealer for service.

It is imperative that your dealer removes all water from the engine and immediately relubricates all internal parts. Electrical devices must be replaced. Delay in completing these actions may allow extensive engine damage.

Frequently check engine compartment for excessive water accumulation; water depth in bilge should be kept well below flywheel housing. Engine compartment must enable proper venting to avoid condensation to build up on inner surfaces.

All repair works on your **Steyr Motors** marine engine should be carried out by a licensed **Steyr Motors** marine dealer with his professional knowledge, trained staff and special-purpose tools to solve all occurring problems. Preferably, all work on your **Steyr Motors** marine engine should be carried out by the **Steyr Motors** marine dealer that sold the equipment to you - he knows you and the equipment.

If problems occur during a trip, bring your engine to the next **Steyr Motors** marine dealer. Information on dealers and distributors can be found at the end of this manual.

## A 13 Bottom painting

If your boat is in water where marine growth is a problem, the use of an antifouling paint will reduce the growth rate.

- Tin base antifouling paint (TBTA or TBTF) is recommended where its use is permitted.
- Copper base antifouling paint may be used, but will require more frequent inspection and replacement of sacrificial anodes. **DO NOT PAINT** any part of the drive unit with copper base antifouling paint.

---

### **NOTICE**

Painting the drive unit with copper base paint will accelerate galvanic corrosion.

- ▶ **DO NOT USE** any graphite base antifouling paint.
- ▶ Vinyl-butyl base antifouling paint is a recommended alternative.

---

### **NOTICE**

Never paint anti-corrosion anodes, or their effectiveness will be lost.

- ▶ See your **Steyr Motors** marine contract partner for an antifouling paint that is suitable for your area.

### **A 14 Boat bottom**

The condition of the boat bottom can affect your boat's performance. Marine growth, present in fresh water as well as salt water, will reduce boat speed. A boat bottom with evidence of marine growth causes a reduction in top speed of 20 percent or more. Periodically clean the bottom of your boat following the manufacturer's recommendations.

---

## A 15 Boating responsibilities

As a boat owner, you have certain responsibilities to others. Be sure that all operators read this manual.

You are legally responsible for all occupants of your boat. Instruct at least one of your passengers in the basic fundamentals of handling your boat in case of an emergency. Show all hands the location of emergency equipment and how to use it. You are required by law to have one locally approved life jacket for each person aboard, plus one approved throwable device for man overboard protection.

Learn the waterway rules of the location in which you are going to operate your boat. Navigable waterways are controlled by federal regulations while inland lakes are controlled by local jurisdictions. Obey these regulations to protect yourself, your passengers and fellow boating enthusiasts.

Thoroughly familiarize yourself with weather station warning system signals and waterway traffic signs.

Contact your local Coast Guard station and take advantage of their seasonal boat inspections and training courses.

### A 15.1 Safety

This manual contains certain information related to the personal safety of you the operator, your passengers and bystanders.

The safety symbol **ATTENTION**: appears next to important information to prevent you and others from being hurt.

The symbol **NOTICE**: appears next to important information to keep machinery from being damaged.

Observe all notices and safety warnings contained in this manual.

## A 16 California proposition 65 warning



### **WARNING**























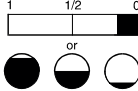







#### **California proposition 65 warning**

Diesel engine exhaust and some of its constituents are known to the state of California to cause cancer, birth defects, and other reproductive harm.

---

## A 17 Symbols

Certain symbols or combinations of symbols may appear on your **Steyr Motors** marine engine or on its accessories. It is very important that you understand their meaning or purpose. If any symbol is not clearly understood, see your DEALER.

<b>"Safety Warning" Symbols</b>			
	Means risk of <b>SERIOUS</b> injury is present. Follow instructions in the Operation, Maintenance & Warranty Manual before using engine or accessory.		Means place shift control in <b>NEUTRAL</b> before starting motor. Follow instructions in Operation, Maintenance & Warranty Manual before starting engine.
	Indicates that contents are under pressure.		Identifies poisonous material.
			Indicates that <b>ELECTRICITY</b> of more than 50 volts is present.
			Indicates a potential fire hazard.
<b>"Position Indicator" Symbols</b>			
	Indicates upward movement.  Example: While boat is at planing speed, activating trim switch to raise the bow of the boat.		Indicates downward movement.  Example: While boat is at planing speed, activating trim switch to lower the bow of the boat.
			Indicates gear shift control positions: <b>FORWARD</b> , <b>NEUTRAL</b> and <b>REVERSE</b>
<b>"Condition" Symbols</b>			
	Identifies the meter which indicates accumulative running hours of engine.		Identifies the meter which indicates battery voltage or amperage.
	Identifies battery or a meter which indicates status of battery-generator charging system.		Indicates the amount of liquid in tank.
	Identifies the meter which indicates engine coolant temperature.		<b>FILTER:</b> Identifies a device which removes contaminants from engine's oil system.
			Identifies the meter which indicates engine coolant pressure.
			Identifies the meter which indicates the pressure of engine's lubricating system.
<b>"Functional Description" Symbols</b>			
	<b>FILTER:</b> Identifies a device which removes contaminants from fuel.		Identifies the <b>EMERGENCY IGNITION CUT-OFF SWITCH</b> . Emergency engine stop.
	Identifies the negative ground or negative voltage connection.		Identifies engine drain plugs and fittings.
	Identifies the <b>STOP SWITCH</b> .  It may also identify <b>STOP</b> position of the throttle control.		
			<b>FUSE:</b> Identifies a device which protects the electrical system from overload.
			Identifies the operating device for starting the engine.
<b>"Instructional" Symbols</b>			
	Indicates <b>FUEL</b> is to be used or <b>FUEL</b> is present.		Means read your Operation, Maintenance & Warranty Manual before operating the product. It contains information or instructions vital for operation of product.
	Indicates <b>OIL</b> is to be used or <b>OIL</b> is present.		<b>ENGINE OIL FILL:</b> Location for introduction of oil into the engine.
			Indicates areas to be lubricated.
			Indicates lubricating oil used in transmissions.

## B Specifications

### B 1 Fuel requirements

The **Steyr Motors** marine engines are designed for maximum fuel economy. To maintain optimum performance use diesel fuel according to EN 590 or equivalent to meet this specification. When temperatures are below  $-7\text{ }^{\circ}\text{C}$  ( $20\text{ }^{\circ}\text{F}$ ), use diesel fuels with additives for low temperature operation.

#### B 1.1 How to select fuel

Fuel quality is an important factor in obtaining satisfactory engine performance, long engine life, and acceptable exhaust emission levels. Direct injected diesel engines are designed to operate on most diesel fuels marketed today. In general, fuels meeting the properties of CEC RF-03-A-84 have provided satisfactory performance.

The ASTM D 975 specification, however, does not in itself adequately define the fuel characteristics needed for assurance of fuel quality. The properties listed in the following fuel oil selection chart have provided optimum engine performance.

#### Fuel selection chart

Properties	Unit	Minimum	Maximum	ASTM Test procedure
Cetane number		52.5		DIN 51773
Density at 15 °C	kg/m <sup>3</sup>	820	845	EN ISO 3675 EN ISO 12185
Distillation 250 °C 350 °C End point 360 °C	% (V/V) % (V/V)	- 85 %	< 65 % 95 %	EN ISO 3405
Flash point	°C	55		EN ISO 2719
CFPP (Cloud point)	°C	-5 (s)	-15 (w)	
Kinematic viscosity 40 °C	mm <sup>2</sup> /s	2	4.50	EN ISO 3104
Sulphur content	mg/kg	-	10.0	EN ISO 20846 EN ISO 20884
Copper corrosion	Rating	Class 1	Class 1	EN ISO 2160
Carbon residue: Conradson number (10 % residue)	% (m/m)	-	0.30	EN ISO 10370
Ash	% (m/m)	-	0.01	EN ISO 6245
Water content	mg/kg	-	200	EN ISO 12937
Oxidation stability	g/m <sup>3</sup>	-	25	EN ISO 12205

## B 2 Engine oil requirements

To obtain the best engine performance and engine life, **Steyr Motors** Turbo Diesel Engine Oil SAE 10W-40 (500830) is recommended. Engine oils are specified by ACEA, API service codes and SAE viscosity numbers. If **Steyr Motors** High Performance Turbo Diesel Engine Oil SAE 10W-40 is not available, it is required to use a reputable brand of engine oil labelled for correct ACEA and API as well as fulfilling SAE 10W-40, see table below.

Refer to oil identification symbol on the container.

---

### CAUTION

**Using the incorrect engine oil can cause hazards or engine damages!**

- ▶ Use engine oil accordingly the specifications listed in table below.
  - ▶ Observe the material safety data sheet.
- 

Item	SE 6 cylinder engines	SE 4 cylinder engines
Initial filling quantity	17.0 litre (inclusive 1 litre oil filter)	11.5 litre (inclusive 1 litre oil filter)
Oil quantity between min and max on oil dipstick	3.5 litre	2.5 litre
Oil change quantity	Approx. 16.0 litre (without oil filter)	Approx. 10.5 litre (without oil filter)
Oil filter	Approx. 1.0 litre	
Oil - specification	SAE 10W-40 API: CI-4, CH-4, CG-4, CF-4, CF ACEA: E6, E7	
Recommended engine oil	Steyr Motors turbo diesel engine oil SAE 10W-40 SMO no. 500830	

During the break in period (20 hours), frequently check the oil level. Higher oil consumption is normal until cylinders are stabilized. The oil level should be maintained between the minimum and maximum mark on the dipstick. The space between the marks represents approximately 3.5 litres (3.7 quarts).

### 2.4 **Service and maintenance schedule** for recommended oil change intervals.

---

### **NOTICE**

- ▶ There are two different oil dip sticks available according to the engine storage procedure.
  - ▶ After first 50 hours of operation change the engine oil and replace the oil filter. Refer to service and maintenance schedule.
-

### Oil identification symbol

Engine oils are specified by ACEA, API service code and SAE viscosity numbers.

These may be found on the label, top of can, or oil identification symbol.

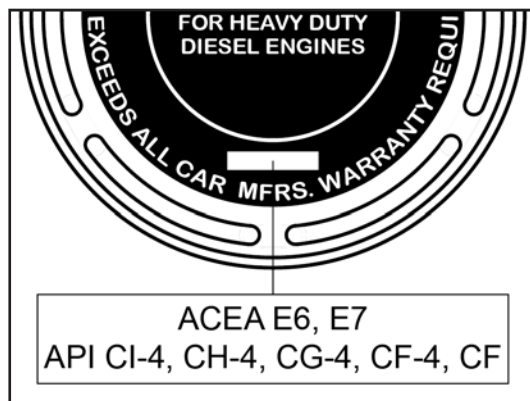

Fig. 11 Top of can

### NOTICE

Some engine oils have several ACEA / API quality ratings.

The specified ACEA /API service letter code must be among these quality ratings.

**Steyr Motors AG** has no values regarding the oil & fuel consumption when an untested engine oil is in use.

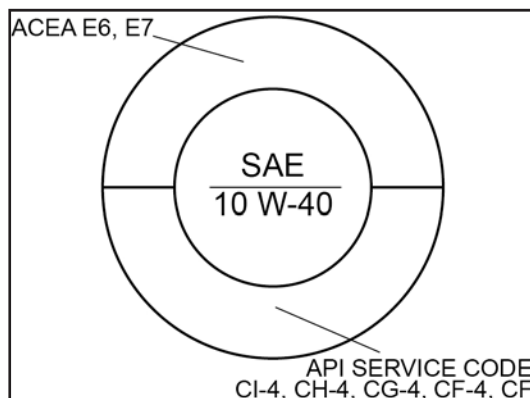

Fig. 12 Oil identification symbol



Fig. 13 Oil sticker

### B 3 Engine coolant requirements

To maintain the specific functions of the engine coolant use engine coolant according the specifications of **Steyr Motors AG** only, see table below.



#### **CAUTION**

**Using the incorrect coolant can cause hazards or engine damages!**

- ▶ Use coolant according to the specification table below.
  - ▶ Observe the material safety data sheet.
- 

Item	Specification 6 cylinder engine	Specification 4 cylinder engine
Coolant filling quantity	15.5 l	10.7 l
Coolant additive specification	Organic acid technology (NAP-Free)	
Water/coolant ratio	50:50 %, deionised water to be used	
Recommended coolant	Steyr Motors engine coolant – 40 C° SMO no. 500831, ready mixed	

The coolant level has to be maintained between the minimum and maximum mark on the coolant expansion reservoir. For the location of the coolant expansion reservoir see the vessel manufacturers operation manual.

---

#### **NOTICE**

The engine coolant has to be checked and replaced periodically. Refer to **2.4 Service and maintenance schedule** for detailed information.

---

## C General information

### C 1 Electronic engine management system

The **Steyr Motors** marine engine is equipped with an Electronic Management System (EMS) that performs the following:

- Controls engine functions to ensure maximum efficiency.
- Self-diagnostic to protect the engine mechanical components against severe damage if operating parameters exceed limits.
- Stores diagnostic data of EMS sensor circuits for maintenance and service.
- Stores abuse data.

#### **i** Information

The following general warning informations is provided from EMS. Indications of faults are depending on the installation done by the vessel manufacturer.

#### **i** Information

Example based on standard **Steyr Motors** instrument panel. Instrument panel may be different on actual vessel.



Fig. 14 Example

## C 2 Diagnostic system

The Electronic Management System (EMS) monitors the following engine parameters such as oil pressure, boost pressure, coolant temperature, sensor control rack, potentiometer accelerator, and speed signal.

The Electronic Management System (EMS) carries out self-diagnostic checks for all input values and sensor connections. In case of irregularities, there is an optical and audible warning signal.

Existing active failures remain stored until the problem has been solved.

To view stored service codes, a PC with diagnostic program (EDT 2.0) is necessary or an SCC2.

Malfunction during operation is categorised in three different categories: intermittent failure, non essential failure and essential failure. The Electronic Management System (EMS) will memorize such errors and if required reduce performance of the engine.

### SCC2 P/No 702420 (front view)



Fig. 15

## **D      Quality guidelines for repair**

### **D 1      Spare parts specification**

Only use genuine **Steyr Motors** spare parts in order to avoid possible loss of performance. For this reason you should insist on the famous quality of genuine **Steyr Motors** spare parts and under no circumstances use spare parts of unknown quality.

Refer to the corresponding spare parts catalogue to identify the required genuine **Steyr Motors** spare part number.

---

#### ***NOTICE***

Paint damage leads to corrosion.  
After repair, all surfaces must be carefully checked for damage to the paintwork.  
Paint damage must be professionally repaired.

---

### D 2 Abbreviations

ACT	Air charge temperature
APS	Absolute Pressure sensor (Barometric)
BDC	Bottom Dead Centre
BMK	Resources to be labelled
CEL	Check engine lamp
Cu	Copper
ECT	Engine coolant temperature
ECU	Electronic Control Unit
EMS	Electronic Management System
Fig.	Figure
ill.	Illustration
ITD	Injection Timing Device
MAssy	Main assembly
max.	maximum
min.	minimum
MSV	Machine safety regulation (ger.: Maschinen Sicherheitsverordnung)
NAP	Nitrite, amine, phosphate
PTO	(Power Take Off) power transmission at front crankshaft end
SMO	Steyr Motors AG
TDC	Top Dead Centre
WS	Wrench size

## E Disposal of automotive waste products

### E 1 List of operating materials

An entire list of the operating material is available in the spare parts catalogue.

### E 2 Disposal of operating materials

Used operating material is to be collected in special containers to enable possible subsequent treatment.



#### Environment

All operating materials for the engine are subject to the Special Waste Act for disposal. The "Special Waste Catalogue" ÖNORM S 2100 refers to the required disposal in Austria.

Respective legal local regulations are to be followed.

The operating and maintenance personnel have to take care that operating material and other material to be regarded as special waste product, are always deposited at a collection site.

Key no.	Description
31 423	Oil contaminated soil or oil bonding agent
54 102	Waste oil
54 104	Fuels
54 202	Lubricants
54 207	Vaseline
54 917	Solid sealing material
54 927	Oil soiled cleaning rags
54 928	Used oil and air filters
55 510	Paint and varnish containing waste material



#### Environment

**Waste oil can endanger the environment.**

- ▶ Dispose waste oil according to the local rules and regulations.
- ▶ Dispose oily rags or contaminated cleaning utensils properly, to avoid fire.



### Environment

**A leakage of operating materials during operation can contaminate soil and water.**

- ▶ Avoid leaks.
  - ▶ Regularly check seal tightness and proper function.
  - ▶ Take immediate action if environmentally hazardous materials reach the environment.
  - ▶ If necessary inform the responsible local authorities about damages.
-

## **F Notes on safety**

### **F 1 General notes on safety**

The general knowledge and training of the personnel and the contents of the "general regulations of safety technology" and machine safety regulations (Maschinen-Sicherheitsverordnung - MSV) are not subject of this chapter.

Inappropriate behaviour and insufficient knowledge of hazard during repair works may cause injury to persons.

In the description of repair works, such sources of danger are marked with

---

#### **CAUTION**

---

The personnel is to be trained accordingly and requested to follow the safety rules.

### **F 2 Guidelines for damage prevention**

The general knowledge and training of the workshop personnel and the contents of the "general regulations of safety technology" and machine safety regulations (Maschinen-Sicherheitsverordnung - MSV) are not subject of this chapter.

Inappropriate behaviour and insufficient knowledge of hazard during repair works may cause injury to persons.

In the description of repair works, such sources of danger are marked with

---

#### **WARNING**

---

While handling with operating materials, take care that these are not applied to visible surfaces.

Lubricants should form a thin film on the surface, surplus lubricants are to be wiped off.

### **F 3 Legal rules**

The following rules and guidelines are valid in Austria. For other countries, follow the local regulations.

Maschinen - Sicherheitsverordnung - MSV (machine safety regulations)

### F 4 Safety in the use of operating material

Dangerous operating material, in the sense of accident prevention, are all operating materials potentially explosive, oxidising, easily flammable, poisonous, dangerous to health and corrosive.

Especially the following material belong to this group:

- Engine oil
- Fuel
- Coolant
- Spirit
- Mineral oils
- Battery acid
- Anti-freeze agent
- Varnishes and diluents
- Solvents
- Fluid seals and nut locks

In case of fire of operating material do not try to extinguish the fire with water. Use carbon dioxide extinguisher or powder extinguisher. Contact fire brigade.

When operating material is spilled, e.g. in case of refuelling, it is to be absorbed by sand, soil or an appropriate bonding agent and to be disposed.



### **CAUTION**

**In order to prevent health hazards, take care of the following:**

- ▶ Avoid direct contact with dangerous operating material, as far as possible.
  - ▶ Change clothes as quickly as possible, if they are soiled with dangerous operating material.
  - ▶ Do not keep oily rags in work clothes.
  - ▶ Clean oil soiled body parts only with products friendly to skin (never use rubbing sand or solvents).
  - ▶ Never fill operating agents in beverage bottles.
-

## F 5 Measures in case of accidents

Products	First Aid		
	Skin	Eyes	Swallowing
Diesel fuel and mineral oils	Remove clothes and clean skin thoroughly with water and soap	Rinse thoroughly with water for at least 10 minutes SEE A DOCTOR!	<p>DO NOT VOMIT</p> <p>The biggest danger after an accidental intake is the fact that liquid could get into lungs by aspiration</p> <p>DO NOT INDUCE VOMITING AND IMMEDIATELY SEE A DOCTOR!</p>
Lubricants			
Anti-freeze agents			
Brake fluid			
Battery acid			



---

# 1 Operation

---



## Environment

**A leakage of operating materials during operation can contaminate soil and water.**

- ▶ Avoid leaks.
  - ▶ Regularly check seal tightness and proper functioning.
  - ▶ Take immediate action if environmentally hazardous materials reach the environment.
  - ▶ If necessary inform the responsible local authorities about damages.
- 



## DANGER

**Risk due to exhaust gases!**

Engine exhaust fumes can result in sickness or death.

- ▶ The exhaust emissions need to be deflected from the control station of the engine. Ensure adequate ventilation.
- 



## DANGER

**Risk of injury due to missing covers!**

Operating the engine without covers can result in injuries due to insert or catch.

- ▶ During operation all covers must be closed and installed.
-

### 1.1 Before starting

Familiarize yourself with the handling of the boat, in particular how to use transmission, and then proceed as follows:

1. Check the bilge for excessive water accumulation. Always keep the bilge clean and dry. Never allow the water level in the engine compartment to exceed the bottom of the oil pan. If water accumulation is unavoidable, install a bilge pump with an automatic control switch.

---

#### **NOTICE**

The water level in the boat's engine compartment will increase when the boat is operated at a high incline before planing speed is reached. Excessive water accumulation in the engine compartment/bilge may cause engine failures.

---

2. Open the raw water intake valve.

---

#### **NOTICE**

Operate the engine only while the raw water supply is assured or the cooling system is equipped with a flushing device. The raw water pump will be damaged and/or the engine will overheat if operated without cooling water.

---

3. Open the fuel stop valve.

---

#### **NOTICE**

Only start the engine when a bubble-free fuel supply is guaranteed. Prior to first start-up of the engine (after installation, after storage etc.), purge the fuel system by "ignition ON" for 3 x 10 sec.

---

If the suction height of the fuel-pump is more than 0.5 m, the fuel supply line must be filled before first start-up of the engine.

4. Check the operating levels of:
  - Engine coolant
  - Engine oil
  - Hydraulic oil
  - Transmission oil
  - Fuel
  
5. Control of electric system:
  - Charge and charge state of battery

### 1.2 Starting the engine (Key switch version)

---

#### **NOTICE**

In order to start the engine quickly and run smoothly, the fuel system must be primed with the aid of the electric fuel pump before the first start and/or after each change of the fuel filter (ignition "ON" several times for approximately 10 seconds). **Prerequisite:** fully filled fuel prefilter!

---

Starting procedure for the **Steyr Motors** marine engine is the same for both cold and warm engines. The engine control unit **automatically regulates the fuel supply and the preheating period**, for any given temperature. Therefore, the throttle lever should remain in neutral position.



Fig. 16

1. To start the engine, move throttle lever into idle position and gear into neutral position.
2. Turn ignition key into position **ignition "ON"**. An audible alarm will sound and the warning lights are illuminated (temporary), indicating the correct function of the audible and visual warning systems.

---

## NOTICE

In the case of a low temperature start wait until the combined oil pressure/glow plug pre-heating indication light is turned off, before you continue with the start procedure.

---

3. Turn ignition key into position “**START**” and hold in this position until “**starting**” of engine, but under no circumstances hold in this position for more than ten seconds.  
If engine does not start, release **ignition key**, **wait 30 seconds** to cool down starter motor, repeat **starting procedure**.
4. As soon as engine starts, release ignition key. The audible alarm will stop when normal oil pressure has been reached.

---

## CAUTION

If engine fails to start within one minute and/or repeated attempts, contact your **Steyr Motors** marine dealer.

- ▶ Never turn ignition key to position “START” when engine is running.
- 

### 1.2.1 Stopping the engine (Key switch version)

1. Move throttle lever into idle position and gear in neutral position.
2. Cool down the engine.
3. Turn ignition key to “OFF” position.

---

## CAUTION

Do not stop engine at speeds above idle or “accelerate” engine while turning off ignition. This may result in engine failures.

---

Download Instrument Panel Documentation from: <https://www.steyr-motors.com>

### 1.3 Starting the engine (Push button version)

---

#### **NOTICE**

In order to start the engine quickly and run smoothly, the fuel system must be primed with the aid of the electric fuel pump before the first start and/or after each change of the fuel filter (ignition "ON" several times for approximately 10 seconds). **Prerequisite:** fully filled fuel prefilter!

---

Starting procedure for the **Steyr Motors** marine engine is the same for cold or warm operating condition. The engine control unit **automatically regulates the fuel supply and the preheating period**, for any given temperature. Therefore, the throttle lever should remain in neutral position.

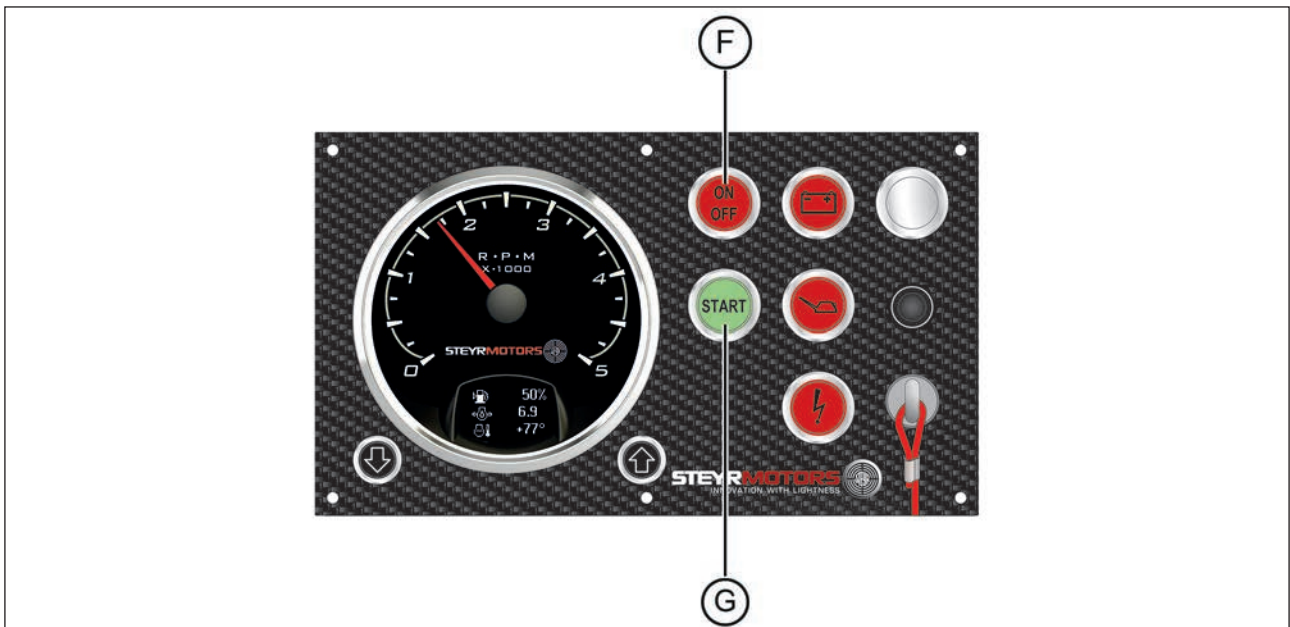

Fig. 17

1. To start the engine, move throttle lever into idle position and gear into neutral position.
2. Press the push button for **ignition (F)** (push button lock in place); An audible alarm will sound and the warning lights are illuminated (temporary), indicating the correct function of the audible and visual warning system.

---

## NOTICE

In the case of a low temperature start, wait until the combined oil pressure/glow plug pre-heating indication light is turned off, then continue with the start procedure.

---

3. Press the button **START (G)** and hold in this position until “**starting**” of engine, but under no circumstances hold in this position for more than ten seconds.  
If engine does not start, release ignition key, wait 30 seconds to cool down starter motor, repeat starting procedure.
4. As soon as engine starts, release start button. The audible alarm will stop when normal oil pressure has been reached.

---

## CAUTION

If engine fails to start within one minute and/or repeated attempts, contact your **Steyr Motors** marine dealer.

- ▶ Never push start button when engine is running.
- 

### 1.3.1 Stopping the engine (Push button version)

1. Move throttle lever into idle position and gear in neutral position.
2. Cool down the engine.
3. Press push button ignition ON/OFF (**F**) to disengage from locking position and to shut OFF the engine.

---

## CAUTION

Do not stop engine at speeds above idle or “accelerate” engine while turning off ignition. This may result in engine failures.

---

Download Instrument Panel Documentation from: <https://www.steyr-motors.com>

### 1.4 Run in procedure after major overhaul

The following run in procedure must be used on **Steyr Motors** engines following a major overhaul, where a major overhaul is defined as a replacement of any or all of the following:

- Crankshaft,
- Piston(s),
- Con rod(s),
- Monoblock

#### 1.4.1 Definitions

- Rated speed            Engine speed with maximum power
- Half engine speed    Half of rated speed

#### 1.4.2 Procedure, work steps

##### Preparation

- Engine filled with oil and coolant to max. levels
- Steyr High Performance Diesel-Engine Oil 10W-40
- Steyr Motors engine coolant (if not available use GlycoShell - 50/50 % water/coolant)
- Steyr Motors engine diagnostic tool connected to the ECU

##### Test method

- Remove the expansion tank pressure cap for degassing the system
- Start the engine
- Run at idle speed for 20 minutes
- Stop the engine
- Check coolant and oil level, top up to max. level if necessary
- Close the expansion tank with the pressure cap
- Start the engine
- Warm up the engine (~ 15 minutes)
- Run the boat minimum for 4 hours at no more than half engine speed
- Check oil level, top up to max level
- Check the error list in the ECU using the diagnostic programme, if no errors continue run in. If errors occurred, contact **Steyr Motors** authorized service partner for further decisions
- Warm up the engine (~ 15 minutes)
- Run the boat minimum for 2 hours at no more than 75 % engine speed
- Check the service code list in the ECU using the diagnostic program, if no errors continue run in. If errors occurred, contact **Steyr Motors** authorized service partner for further decisions

- Warm up the engine (~ 15 minutes)
- Start the **Steyr Motors** diagnostic tool data logger
- Run the boat minimum for 20 minutes at full rated speed
- Stop diagnostic tool data logger and save the file (filename: engine number and date  
E.g. 68225765\_20080910.dat)
- Check the service code list in the ECU. If errors occurred, contact **Steyr Motors** authorized service partner for further decisions
- Send the data Log file to **Steyr Motors** authorized service partner
- Check coolant and oil level at cold engine, top up to max. level if necessary
- Continue using the engine according to **Steyr Motors** Operator Manual

### 1.5 Engine break-in procedure

The following procedure must be used on new and rebuilt **Steyr Motors** marine engines. All **Steyr Motors** marine engines have been run for a short period as a final test at the factory. You must follow the engine break-in instructions during the first 20 running hours to ensure maximum performance and longest engine life.

---

#### **NOTICE**

Non-observance of break-in instructions may cause severe engine failure.

- ▶ Follow the break-in instructions on new and rebuilt **Steyr Motors** engines.
- 

#### 1.5.1 First two hours

For the first five to ten minutes of operation, run the engine at a fast idle, below 1.500 rpm. For the remaining first two hours of operation vary the engine speed frequently by accelerating to approximately 75 % throttle for two to three minutes cycles.

---

#### **NOTICE**

To ensure maximum performance and longest engine life do not run the engine at a constant rpm for long periods during the initial two hours of break-in.

- ▶ Change the engine speed during the initial two hours of the break-in.
- 

---

#### **NOTICE**

The ECU monitors load during the first two hours of engine operation. If the load on the engine is too high, the user is warned by the "Check Engine Lamp".

If the operator gets an alert, the throttle position must be reduced until the signal extinguishes.

---

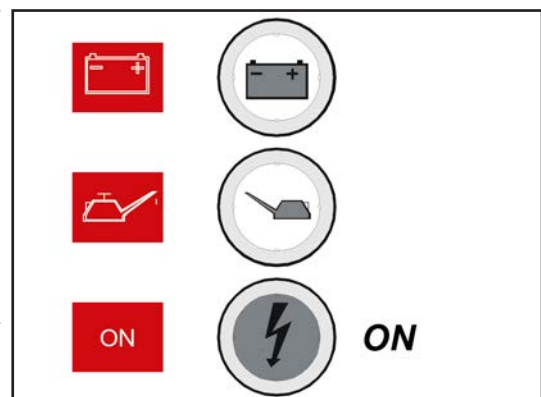

Fig. 18

---

### 1.5.2 Next eight hours

For the next eight hours, continue to run the engine at approximately 75 % throttle or less. Occasionally reduce throttle to lower loads and let the engine temperature cool down. During this eight hours of running it is permissible to run at full throttle for periods of less than two minutes.

---

#### **NOTICE**

To ensure maximum performance and longest engine life do not run the engine at a constant rpm for long periods during break-in.

- ▶ Vary the engine speed during break-in.
- 

### 1.5.3 Final ten hours of break-in

During the final ten hours of break-in, the engine may run at full speed for five to ten minutes. Continue to operate engine within the specified temperature, at moderate engine speed to cool down the engine between full power cycles.

---

#### **NOTICE**

To ensure maximum performance and longest engine life, do not run the engine at a constant rpm for long periods during break-in.

- ▶ Change the engine speed during break-in.
- 

**During break-in period, be particularly observant of the following:**

1. Check engine oil level daily. Always maintain oil level in the desired range between the "MIN" and "MAX" marks on dipstick. When refilling engine oil, refer to **B 2 Engine oil requirements**.
2. Check oil pressure control lamp. If the lamp lights up as soon as the boat changes its position (while turning, straightening up the boat or planing), check the oil level in the engine housing by means of dipstick. If necessary, add oil (DO NOT OVER-FILL). In case that the oil pressure control lamp is still illuminated with correct oil level, have the engine checked by your **Steyr Motors** marine dealer as to malfunction of signal or oil pump.

### **NOTICE**

During normal operation of engine, oil pressure will rise as rpm increases and fall as rpm decreases. In general, oil pressure will be higher with cold engine oil and specific rpm than with hot engine oil.

---

3. Check the engine temperature indication. The normal operating temperature should be between 80 - 95 °C. In case of audible alarm, check the coolant level in the expansion tank (only with cold engine before starting).
  4. Deviations from normal operating conditions will be indicated by warning lights and audible alarm.
- 

### **CAUTION**

In case of non-observance of break-in instructions, warranty will be void.

Engine to be filled with specified oil quality only.

---

Engine to be filled with recommended oil quality only. See chapter **B 2 Engine oil requirements**.

#### **1.5.4 Operation after break-in**

The engines specified in this manual are intended to be operated at different speeds and loads, but not allowing full load of the engine for more than one hour per 12 running hours. Economic driving may be achieved at the following speeds, which will prolong engine life and reduce emissions and noise:

<b>6 cylinder</b>		<b>4 cylinder</b>			
SE126E32	<b>3000 rpm</b>	SE236S36	<b>3400 rpm</b>	SE144E38	<b>3600 rpm</b>
SE156E34	<b>3200 rpm</b>	SE266E40	<b>3800 rpm</b>	SE164E40	<b>3800 rpm</b>
SE186E38	<b>3600 rpm</b>	SE266S36	<b>3400 rpm</b>		
SE236E40	<b>3800 rpm</b>	SE286E40	<b>3800 rpm</b>		
		SE306J38	<b>3600 rpm</b>		

When starting a cold engine, always allow the engine to warm up slowly. Never run the engine at full speed until operating temperature is reached. During the first 50 running hours, check the oil level frequently.

---

### **NOTICE**

Do not run up engine at raised idling speed without load!

---

## 1.6 Shifting

### Example: single lever shift control system

1. If the gear shift mechanism is disengaged, move the control lever to neutral position. The shift mechanism will automatically engage.
2. To go FORWARD - press the neutral lock button if fitted, and move the control lever forward. Throttle movement will begin after forward gear engagement.
3. To go in REVERSE - press the neutral lock button if fitted, and move the control lever backwards. Throttle movement will begin after reverse gear engagement.
4. To go from FORWARD to REVERSE, or REVERSE to FORWARD, always pause at NEUTRAL and allow engine speed to return to idle and vessel speed below 1 kn.
5. After shifting is completed, continue to move the control lever slowly in the desired direction to increase speed.

---

### **NOTICE**

A sudden increase in shifting torque on the remote control lever indicates a possible problem in the shifting system. If so, see your **Steyr Motors** dealer as soon as possible for proper diagnosis and necessary service adjustment. Continued operation under this condition could result in damage to the shifting mechanism.

---

### 1.7 Remote control operating instructions

Your boat may be equipped with one of the following remote controls:

- Single lever control
- Dual lever control for twin engines

#### **NOTICE**

If other than **Steyr Motors AG** matched remote controls are used, follow the manufacturer's recommendation.

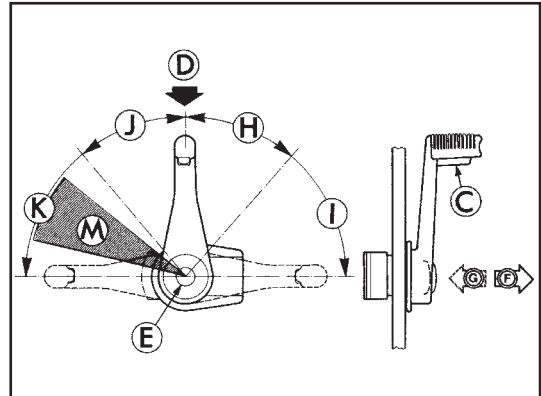

Fig. 19

Remote controls have the following important features:

- A single lever which allows to select forward or reverse gear, regulate engine speed, and ensure shifting is done at low engine speed.
- A start-in-neutral-only feature which will protect you from starting your **Steyr Motors** marine engine with engaged gears.

The side mount control has a neutral lock button (**C**) located in the control lever which must be pressed to permit shifting from neutral to forward or reverse. The top mount controls do not have a neutral lock, but there is a neutral ratchet position.

#### **Side mount control**

To disengage shift mechanism:

1. Place control lever into neutral position (**D**).
2. Press both neutral lock button (**C**) and shift disengage button (**E**).
3. Move control lever forward to increase throttle.

(**F**) Shift mechanism engaged

(**G**) Shift mechanism disengaged

The neutral lock and shift mechanism will automatically engage when the control lever is returned to neutral position.

### Top mount control

To disengage shift mechanism:

1. Grasp the control lever hub and pull straight in for approximately  $\frac{1}{4}$  " (6 mm).
2. Move control lever forward to increase throttle.

The shift mechanism will automatically engage when control lever is returned to neutral.

Your boat may be equipped with remote controls other than those described above. When not using **Steyr Motors** marine engine matched controls, ask your dealer for operating instructions for the remote control used in your boat since operation and function may differ from **Steyr Motors** marine engine matched remote controls.

---

### CAUTION

Your boat should be equipped by manufacturer with a remote control with protection against starting in gear. Only use a remote control with start-in-neutral-only feature. This feature can prevent injury resulting from unexpected turning of the propeller and sudden movement of the boat.

---

### 1.8 How to shift and control speed

---

#### **NOTICE**

Do not shift into FORWARD or REVERSE unless engine is running. Damage to the shift mechanism could result from trying to shift without the engine running.

---

Move the control lever to neutral position **(D)**. The shift mechanism will automatically engage. Press neutral lock button **(C)** on some single side mount control and move the control lever to shift into forward or reverse. The throttle will begin to advance after gear engagement. Continue to move the control lever slowly in the desired direction to increase speed.

- (H)** Reverse shift range
- (I)** Reverse throttle range
- (D)** Neutral position
- (J)** Forward throttle range
- (K)** Forward shift range

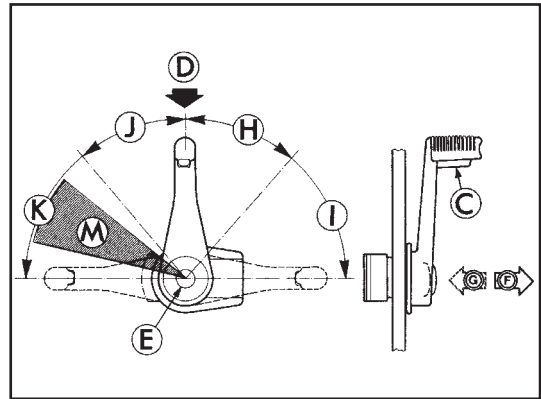

Fig. 20

#### 1.8.1 Fuel economy

Using the fuel economy throttle range **(M)** can save fuel depending on boat load and hull design. When the boat reaches top speed, reduce engine speed slightly. Make sure the boat maintains to plane when reducing engine speed. Continue to reduce engine speed slightly while maintaining to plane. Do not allow boat to fall off plane. This will give a comfortable ride and help to save fuel at the same time.

#### 1.8.2 Gear box - information

---

#### **NOTICE**

You are requested to follow the instructions and recommendations provided by the marine gear box manufacturer.

---

#### 1.8.3 Fixed speed switch

---

#### **NOTICE**

Shift into gear must only be done with idling speed!

---

## 1.9 Instrument panel (Key switch version)

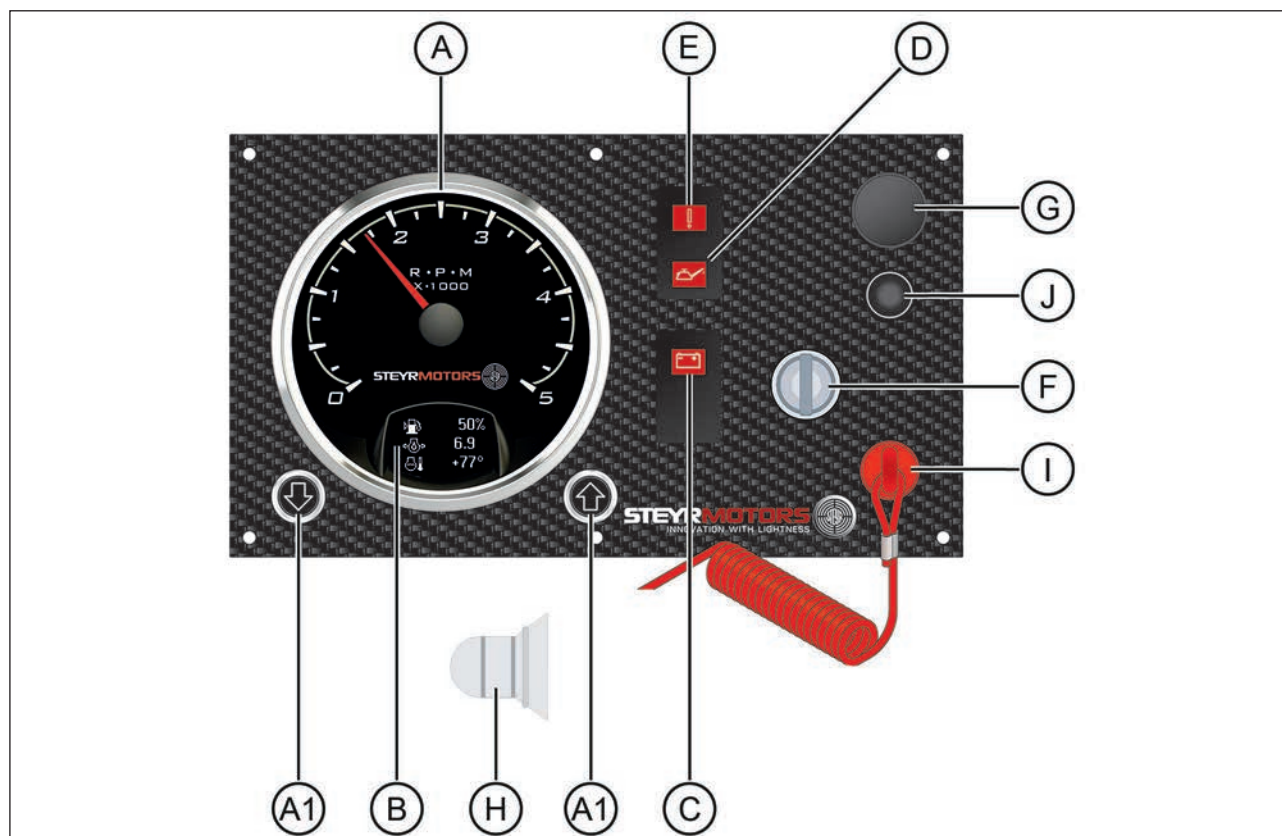

Fig. 21

	Description
<b>A</b>	Tachometer
<b>A1</b>	Function buttons
<b>B</b>	Engine parameter display
<b>C</b>	Warning light - battery charge
<b>D</b>	Combined light preheating control & warning light - engine oil pressure
<b>E</b>	Warning light - CEL check engine lamp

	Description
<b>F</b>	Ignition key
<b>G</b>	Blind plug - installation option for key switch constant revolution
<b>H</b>	Audible warning device (installed on rear side of panel)
<b>I</b>	Emergency cut off switch (lan-yard)
<b>J</b>	Circuit breaker (10 amp)

If you should need additional instruments or accessories, please contact your **Steyr Motors** marine dealer.

# Operation

## 1.9.1 Instrument panel legend

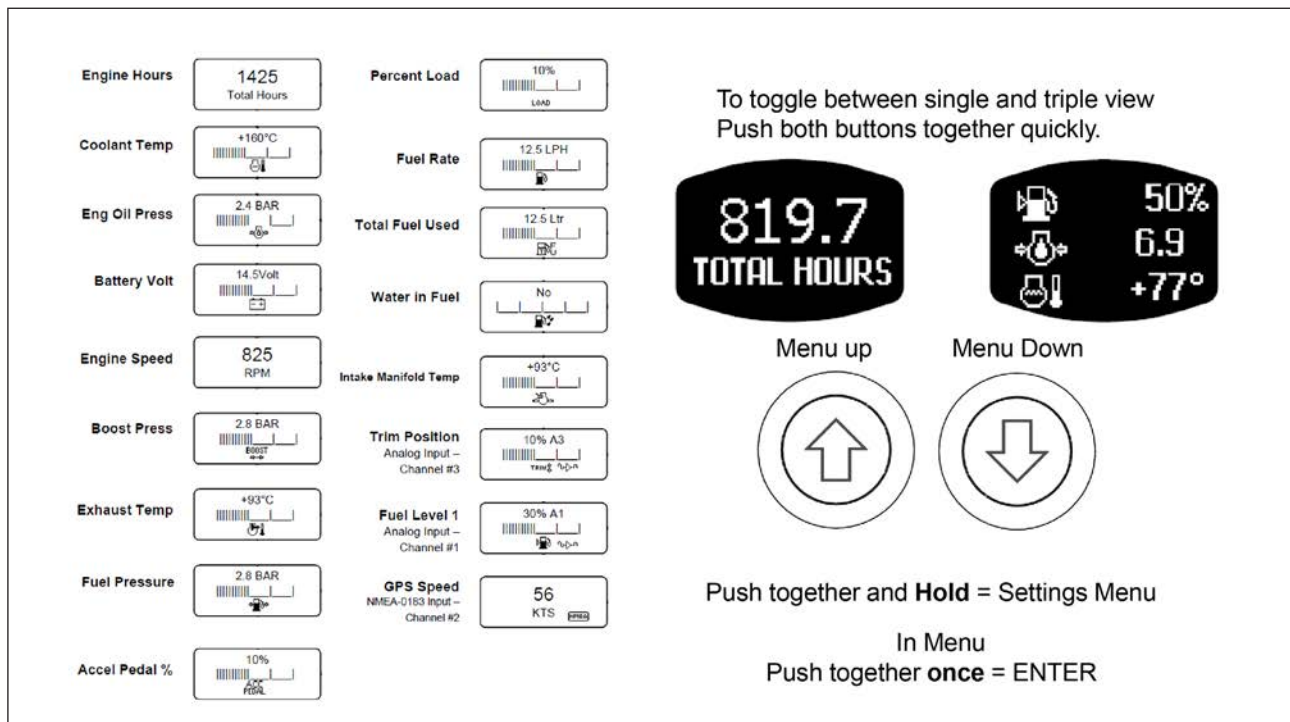

Fig. 22

## 1.9.2 Instrument indication, normal operation (Key switch version)

### 1. Ignition ON ( ... before starting)



Fig. 23

System check - see light indication

### NOTICE

At low temperature condition (cold weather) the combined light for glow plug preheating & engine oil pressure will not extinguish after 1 sec. (glow plug preheating phase) In this case start engine immediately after the light extinguishes.

[X] = ON (1 sec.)

### 2. Ignition ON ( ... before starting)



Fig. 24

Indication memorized service codes

[Y] = ON (5 sec.)

### 3. Engine running (after start)



Fig. 25

Normal condition

### NOTICE

For further information see: "Table - Error indication on instrument panel".

[Z] = OFF

## 1.10 Instrument panel (Push button version)

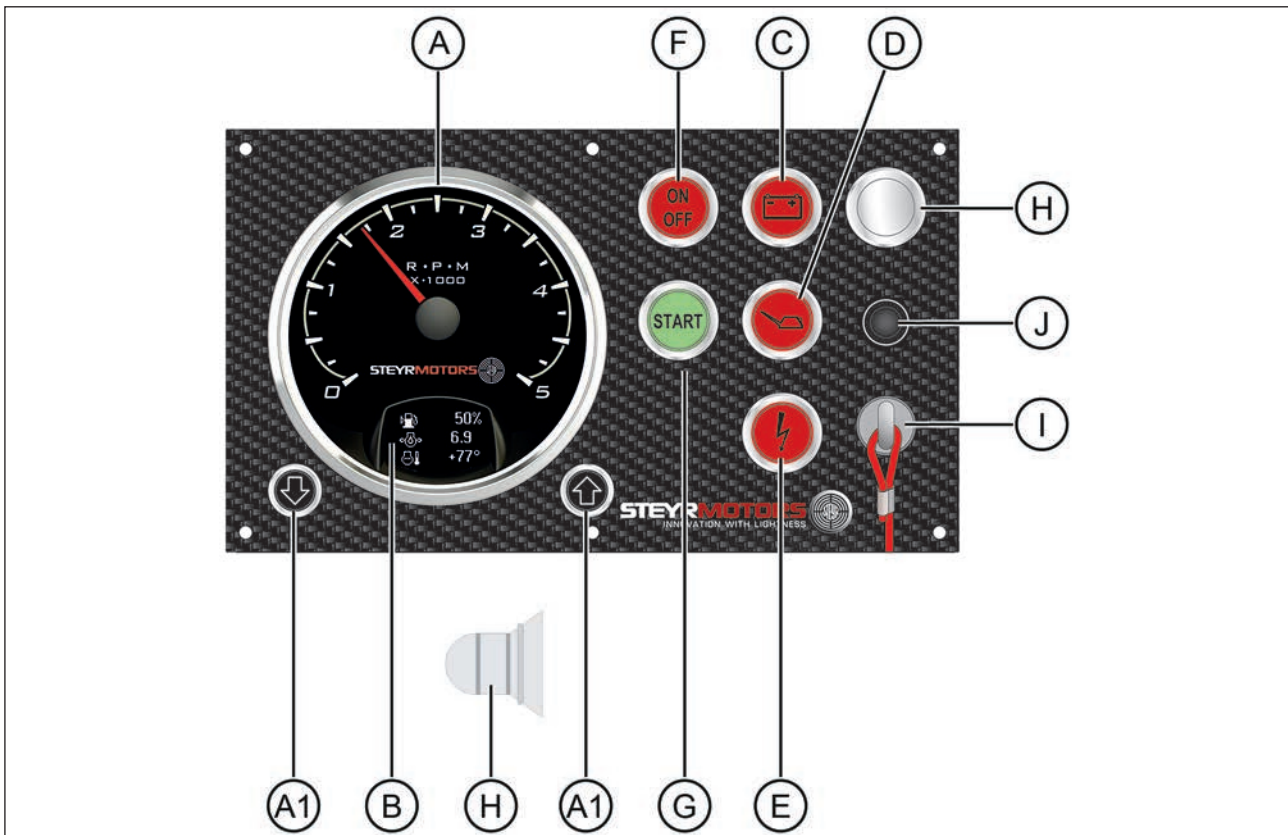

Fig. 26

	Description
<b>A</b>	Tachometer
<b>A1</b>	Function buttons
<b>B</b>	Engine parameter display
<b>C</b>	Warning light - battery charge
<b>D</b>	Combined light preheating control & warning light - engine oil pressure
<b>E</b>	Warning light - CEL check engine lamp

	Description
<b>F</b>	Push button - ignition ON/OFF (red)
<b>G</b>	Push button - START (green)
<b>H</b>	Audible warning device (installed on rear side of panel)
<b>I</b>	Emergency cut off switch (lan-yard)
<b>J</b>	Circuit breaker (10 amp)

### NOTICE

Instrument gauges are automatically illuminated if ignition is turned ON.

In the case of inversion the engine will be automatically shut off, in order to allow normal operation later.

The ignition push button (**F**) must be switched OFF and ON again, then the engine can be restarted via the push button START (**G**).

### 1.10.1 Instrument panel legend

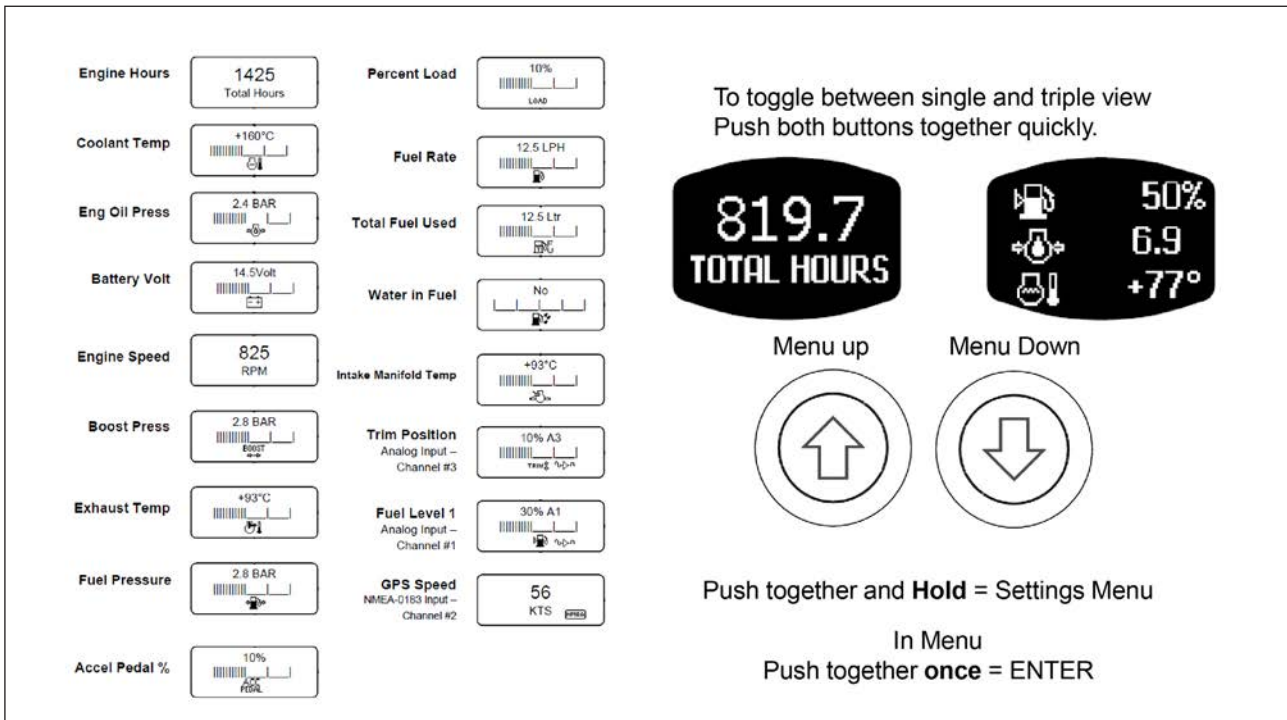

Fig. 27

1.10.2 Instrument indication, normal operation (Push button version)

1. Ignition ON ( ... before starting)



System check - see light indication

**NOTICE**

At low temperature condition (cold weather) the combined light for glow plug preheating & engine oil pressure will not extinguish after 1 sec. (glow plug preheating phase) In this case start engine immediately after the light extinguishes.

[X] = ON (1 sec.)

Fig. 28

2. Ignition ON ( ... before starting)



Indication memorized service codes

[Y] = ON (5 sec.)

Fig. 29

3. Engine running (after start)



Normal condition

**NOTICE**

For further information see: "Table - Error indication on instrument panel".

[Z] = OFF

Fig. 30

## 1.11 Emergency cut off switch (Lanyard)

An emergency cut off switch is a feature on the instrument panel. Use of this switch is highly recommended. To properly use this feature, attach the lanyard securely to your clothing. Do not attach the lanyard to clothing that will tear away before the lanyard is pulled from switch to stop the engine. Using this switch is simple and should not interfere with normal operation of the boat. Care must be taken to avoid accidental pulling of lanyard during normal operation. Unexpected loss of forward motion will occur. This could allow occupants to be thrown forward. In case the emergency cut off switch had been activated (lanyard pulled) the engine can be restarted by a person if; the pull knob (1) of the emergency switch is being pulled and held in this position. While holding the pull knob proceed with the normal start procedure and start engine. The engine will immediately stop if the pull knob is released under these circumstances.



Fig. 31



### CAUTION

The emergency cut off switch can only be effective when in good working condition. Observe the following:

- Lanyard must always be free of entanglements that could hinder its operation.
- Once a month, check switch for proper operation. With engine running, pull lanyard. If engine does not stop, see your **Steyr Motors** dealer for replacement of switch.

Do not use the Emergency cut off switch as a "Stop" switch. This will reduce the life time of the Emergency cut off switch!

### 1.12 Warning lights and audible alarm

Your boat with the **Steyr Motors** marine engine is equipped with three warning lights and one audible alarm (mounted behind the instrument panel) to indicate the following operation condition or system deficiencies (The ECU will also reduce the engine power in case an important operating parameter limit has been exceeded).

- Indication pre-warming phase (combined indication through oil pressure light. Becomes active if ambient engine coolant temperature is below 20 °C / 68 °F)
- Break-in; over load warning
- Engine oil pressure too low
- High coolant temperature
- Sensors or sensor circuit defect

After ignition is turned “ON” the indication/warning lights are illuminated and the warning horn will sound for a second, this serves as a functional check for the optical/audible warning system.

The indication light and the warning horn remain switched on for 5 sec. after ignition “ON” a defective sensor or sensor circuit has been detected and stored in the Engine Control Unit (ECU) (see section Instrument Panel).

Please contact your nearest **Steyr Motors** marine dealer to get professional assistance to verify the deficiency and to correct any possible failure.

If the engine oil pressure is too low, the following alarms are issued:

V30000 (from 2021)	Oil pressure indication light on and the audible alarm sounds
V50000 (until 2021)	“CEL” on, oil pressure indication light on 1 x sec. and the audible alarm sounds

The engine power will be limited. In this case proceed as follows:

- Check engine oil level, respectively add engine oil if necessary (refer to chapter Fuel and Lubricants)
- Restart engine and watch the oil pressure light. The warning light has to extinguish within 3 or 4 seconds after the start. If this does not happen **the engine must be stopped immediately** (Ignition “OFF”).

In case of an overheating of the exhaust gas cooling system, the warning light “engine control” flashes and the audible alarm sounds (2 times per second); the engine power is reduced. In this case, proceed as follows:

- IMMEDIATELY reduce the engine to idle speed.
- Check and clean the raw water filter.
- Check the coolant temperature gauge for overheating of engine coolant. If the coolant temperature gauge indicates overheating of engine coolant, switch for a short time to REVERSE to remove a possible clogging of the raw water inlet through large plastic parts etc., and then to FORWARD. Let the engine run at idle speed for some minutes. If the temperature gauge still indicates an overheating of the engine, the engine is to be stopped. Restart the engine only after having found and eliminated the cause for alarm. See “loss of power” in trouble shooting chart, technical data and in maintenance section. Check coolant level and if necessary, refill coolant until an adequate coolant level is achieved. If the cause for optical/audible alarm cannot be found, consult your **Steyr Motors** marine dealer.

## 1.13 Electronic engine control unit (ECU)

The **Steyr Motors** marine engine is equipped with an electronic engine control unit (ECU) that performs the following:

- Controls engine functions to ensure maximum efficiency.
- Self-diagnostic to protect the engine from damage if operating parameters are exceeded.
- Stores diagnostic data of ECU server circuits for maintenance and service.
- Stores abuse data.

Engine power is reduced if:

Table valid for engines from year of manufacture 2021				
Operating parameter	Effect noticed	Panel indication	Additional tool-readings	Action or possible reason
High engine coolant temperature limit exceeded	Reduction of engine speed	Horn ON 1 x p. sec. indication light "CEL" ON 1 x p. sec. Gauge reading > 105 °C	Steyr Diag Power limitation	See service manual, fault finding chart: Cooling system
Defect - engine coolant sensor or sensor connection	Reduction of engine speed	Horn ON 1 x p. sec. indication light "CEL" ON 1 x p. sec.	Steyr Diag Service code	Sensor or connector failure; see service code list
Exhaust temperature limit exceeded	Reduction of engine speed	Horn and indication light "CEL" ON 2 x p. sec.	Steyr Diag Power limitation	See service manual, fault finding chart: Raw water cooling system
Defect - Exhaust temperature sensor or sensor connection	Reduction of engine speed	Horn and indication light "CEL" ON 2 x p. sec.	Steyr Diag Service code	Sensor or connector failure; see service code list
Oil pressure below limit	Reduction of engine speed	Horn and indication light "CEL" continuous ON Oil pressure indication light 1 x p. sec.	Steyr Diag Power limitation	See service manual, fault finding chart: Engine oil system

## Operation

Table valid for engines from year of manufacture 2021				
Operating parameter	Effect noticed	Panel indication	Additional tool-readings	Action or possible reason
Defect - Oil pressure sensor or sensor connection	Reduction of engine speed	Oil pressure indication light continuous ON	Steyr Diag Service code	Sensor or connector failure; see service code list
Insufficient boost pressure or defective sensor	Reduction of engine speed		Steyr Diag Power limitation	See service manual, fault finding chart: Air charge system
Engine speed sensor fault	Irregular engine speed or stalled engine	No RPM indication on tachometer	Steyr Diag Service code	See service manual, fault finding chart: Speed sensor
Engine speed remains at idle	No increase of engine speed if throttle is moved to max.		Steyr Diag Service code	See service manual, fault finding chart: Accelerator potentiometer failure
Control solenoid	Irregular engine speed or stalled engine	In case of rack error horn and indication light "CEL" ON	Steyr Diag Service code	Check control rack for ease of movement, see <b>4.5.1.1 1st Preservation procedure</b> step 11 See service manual, Measure Y1/ FMS fuel metering solenoid - control solenoid

Table valid for engines until year of manufacture 2020				
Operating parameter	Effect noticed	Panel indication	Additional tool-readings	Action or possible reason
High engine coolant temperature limit exceeded	Reduction of engine speed	Horn ON 2 x p. sec. Gauge reading > 107 °C	Steyr Diag Power limitation	See service manual, fault finding chart: Cooling system
Defect - engine coolant sensor or sensor connection	Reduction of engine speed	Horn ON 2 x p. sec.	Steyr Diag Service code	Sensor or connector failure; see service code list

Table valid for engines until year of manufacture 2020				
Operating parameter	Effect noticed	Panel indication	Additional tool-readings	Action or possible reason
Exhaust temperature limit exceeded	Reduction of engine speed	Horn and indication light "CEL" ON 2 x p. sec.	Steyr Diag Power limitation	See service manual, fault finding chart: Raw water cooling system
Defect - Exhaust temperature sensor or sensor connection	Reduction of engine speed	Horn and indication light "CEL" ON 2 x p. sec	Steyr Diag Service code	Sensor or connector failure; see service code list
Oil pressure below limit	Reduction of engine speed	Horn continuous and Oil indication light continuous switched ON	Steyr Diag Power limitation	See service manual, fault finding chart: Engine oil system
Defect - Oil pressure sensor or sensor connection	Reduction of engine speed	Oil pressure indication light switched ON 1 x p. sec.	Steyr Diag Service code	Sensor or connector failure; see service code list
Insufficient boost pressure or defective sensor	Reduction of engine speed		Steyr Diag Power limitation	See service manual, fault finding chart: Air charge system
Engine speed sensor fault	Irregular engine speed or stalled engine	No RPM indication on tachometer	Steyr Diag Service code	See service manual, fault finding chart: Speed sensor
Engine speed remains at idle	No increase of engine speed if throttle is moved to max.		Steyr Diag Service code	See service manual, fault finding chart: Accelerator potentiometer failure
Control solenoid	Irregular engine speed or stalled engine	In case of rack error horn and indication light "CEL" ON	Steyr Diag Service code	Check control rack for ease of movement, see <b>4.5.1.1 1st Preservation procedure</b> step 11 See service manual, Measure Y1/ FMS fuel metering solenoid - control solenoid

### 1.14 Diagnostic system

The electronic engine control unit monitors the following engine parameters:

- Oil pressure,
- Boost pressure,
- Coolant temperature,
- Exhaust pipe temperature (hi-riser),
- Sensor control rack,
- Potentiometer accelerator,
- Speed signal

The ECU carries out self-diagnostic and/or plausibility checks for all input values and sensor connections. In case of irregularities, there is an optical or audible warning signal (see **Table - Error Indication on Instrument Panel**).

Stored service codes can be selected and cleared after elimination of deficiency via SCC (**Steyr Control Center**).

Please consult authorized **Steyr Motors** service partners to assist in fault finding procedure if necessary.

Malfunction during operation is ranked in three different categories intermittent failure, non essential failure and essential failure.

#### SCC2 P/No 702420 (front view)



Fig. 32

## 1.15 Propellers

### 1.15.1 Twin installations

All **Steyr Motors** marine engine inboard models can also be set up for counter-rotation for twin installation. This is done by inverting direction of cable lines on shift lever in order to achieve a counter-rotation of propeller.

Counter-rotation is accomplished in the gearbox. The propeller, propeller shaft and output gear are the only parts that counter-rotate. The engine always has standard rotation.

It is customary to operate your propeller as shown on this illustration for twin installation.

Some boat manufacturers may set up twin installations the opposite way. When propellers and/or cable lines are removed, care must be taken to attach them at the same position as before, and that the propellers are not exchanged.

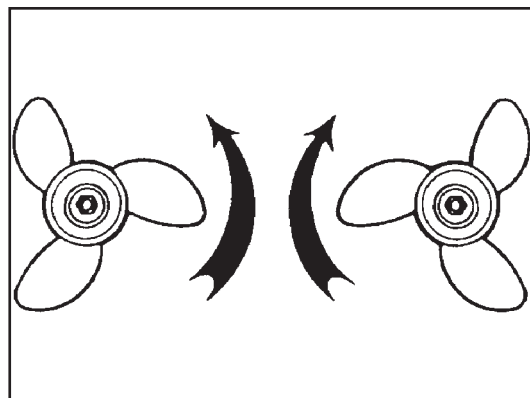

Fig. 33

### 1.15.2 Optional propellers

Propellers are available in all regular sizes for both right and left-hand rotation. Stainless steel has greater strength and durability than aluminium. This allows the stainless steel propeller blades to be thinner and still maintain more beam strength than aluminium propellers. The result is a more efficient propeller that gives better performance and more fuel economy.

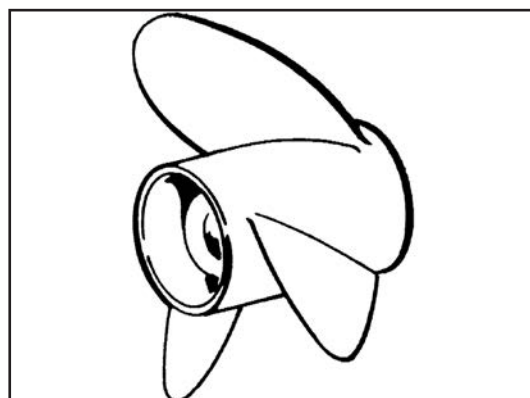

Fig. 34

### 1.15.3 Propellers

Right-hand propellers rotate clockwise to propel a boat forward. Right-hand propellers are considered standard-rotation propellers. To identify a right-hand propeller, note the angle **(A)** of the blade as seen from port side.

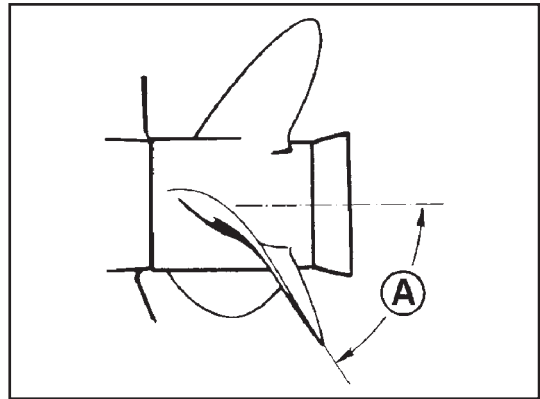

Fig. 35

Left-hand propellers rotate counter clockwise to propel a boat forward. Left-hand propellers are considered counter-rotation propellers. To identify a left-hand propeller, note the angle **(B)** of the blade as seen from port side.

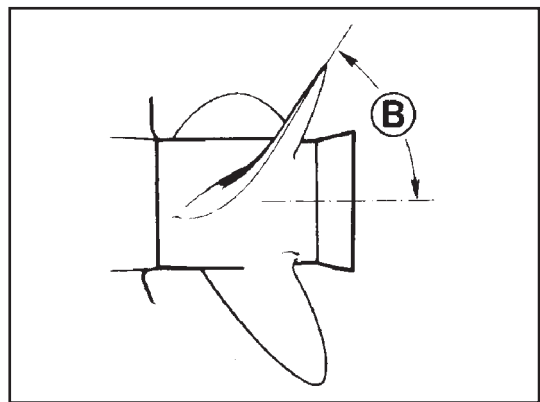

Fig. 36

---

### **NOTICE**

Never interchange a right-hand propeller with a left-hand propeller. This would result in the boat being propelled in reverse when propulsion units are operated in forward gear, and forward when propulsion units are operated in reverse gear. To help you better understand and show the difference between left-hand and right-hand propellers, see figures.

After having the propellers serviced, always shift into FORWARD or REVERSE at idle speed and determine whether the boat moves in the right direction. If the boat moves in the OPPOSITE direction, the propellers have not been installed properly.

---

### **CAUTION**

Failure to perform above test could result in loss of control.

---

#### 1.15.4 Propeller torque

The torque of the propeller creates forces that are transmitted to the boat. This can cause the boat to lean to one side (list).

The forces created by the counter-rotating propeller are opposite to the forces created by the standard rotating propeller. When the vertical drives are trimmed equal, these opposite forces balance each other.

#### 1.15.5 Propeller care

A damaged or unbalanced propeller will cause excessive vibration and a loss of boat speed. Under these conditions, stop the engine and check the propeller for damage. If the propeller seems to be damaged, have it checked and repaired by your local **Steyr Motors** marine dealer. Always carry a spare propeller and replace the damaged propeller as soon as possible.

---

### ***NOTICE***

Never run with a damaged propeller. Running with a damaged propeller can result in damage to drive components and engine.

---

#### 1.16 Water jet

When using water jet drives, please contact your **Steyr Motors** marine dealer. As to information on function and application, please refer to respective documents and documentation of the drive manufacturer.

#### 1.17 Operating procedure for freezing temperatures

When freezing temperatures are forecast and the boat will be operated and left in the water, the propeller must remain in the tilted down (submerged) position at all times to prevent water in the vertical drive from freezing. Upon completion of engine operation, drain the engine as described in Off-Season Storage Preparations.

### 1.18 Salt water operation

Fresh water to flush the raw water circuit is recommended after use in salt, polluted, or brackish water to prevent deposits from clogging and corroding the cooling passages. Contact your **Steyr Motors** marine dealer to obtain an Engine Flushing Kit that allows flushing of the engine when in or out of the water.

---

#### **NOTICE**

Use in salt or brackish water may require additional anti-corrosion protection.

---

---

#### **NOTICE**

START and RUN diesel engine while raw water circuit is flushed with fresh water!

---

### 1.19 High altitude operation

Your **Steyr Motors** marine engine is specified to operate within an altitude from a sea level of 1000 meters without any performance loss. Operation in altitudes above 1000 meters are not recommended.

## 1.20 Fuel system

### 1.20.1 Fuel pump

The **Steyr Motors** marine engine is equipped with an electric fuel pump. It is turned “ON” and “OFF” with the key switch. If the engine is not started within 10 seconds after turning the key switch “ON”, the fuel pump is automatically turned off.

### 1.20.2 Fuel system checks

Fill the tank with the recommended fuel. Keeping tanks full reduces water condensation and helps keep fuel cool, which is important to engine performance.

Make sure that fuel supply valves (if used) are open, and valve cock seals are absolutely (gas) tight.

---

#### **NOTICE**

Do not dry run fuel pump!

---

To insure a prompt start and an even run of the engine, the fuel system is to be rinsed by means of the electric fuel pump (ignition “ON” several times for approx. 10 sec.) before starting the engine the first time and/or after every replacement of a fuel filter.

Refill fuel at the end of each day’s operation to prevent condensation build up in tank. Condensation formed in a partially filled tank contaminates the fuel and promotes the growth of microbial organisms that can block fuel filters and restrict fuel flow.

If the engine is equipped with a fuel/water separator, drain off any water that has accumulated. Water in fuel can seriously affect engine performance and damage injection equipment reducing engine life expectancy.

**Steyr Motors** recommends installing a pre-fuel filter with water separating capability. The filter flow rate must allow a flow rate of 330 l/h for 6 cylinder and  $\geq 240$  l/h for 4 cylinder engines with a maximum permissible pressure drop rate of less than 200 mbar.

## Operation

### 1.20.3 Fuel contamination

In the marine environment, the most likely fuel contaminants are water and microbial growth (black “slime”). Generally, this type of contamination is the result of poor fuel handling practices. Black “slime” requires water in the fuel to form and grow; the best prevention is to change or refill the fuel regularly.

### NOTICE

A galvanized steel tank should never be used for fuel storage, because the fuel reacts chemically with the zinc coating forming powdery flakes which can quickly clog the fuel filters and damage the fuel pump and injectors.

### 1.20.4 Fuel system (from year of manufacture June 2024)

The externally installed fuel system is standard equipment for all 6-cylinder and 4-cylinder Marine engine types from **Steyr Motors**.

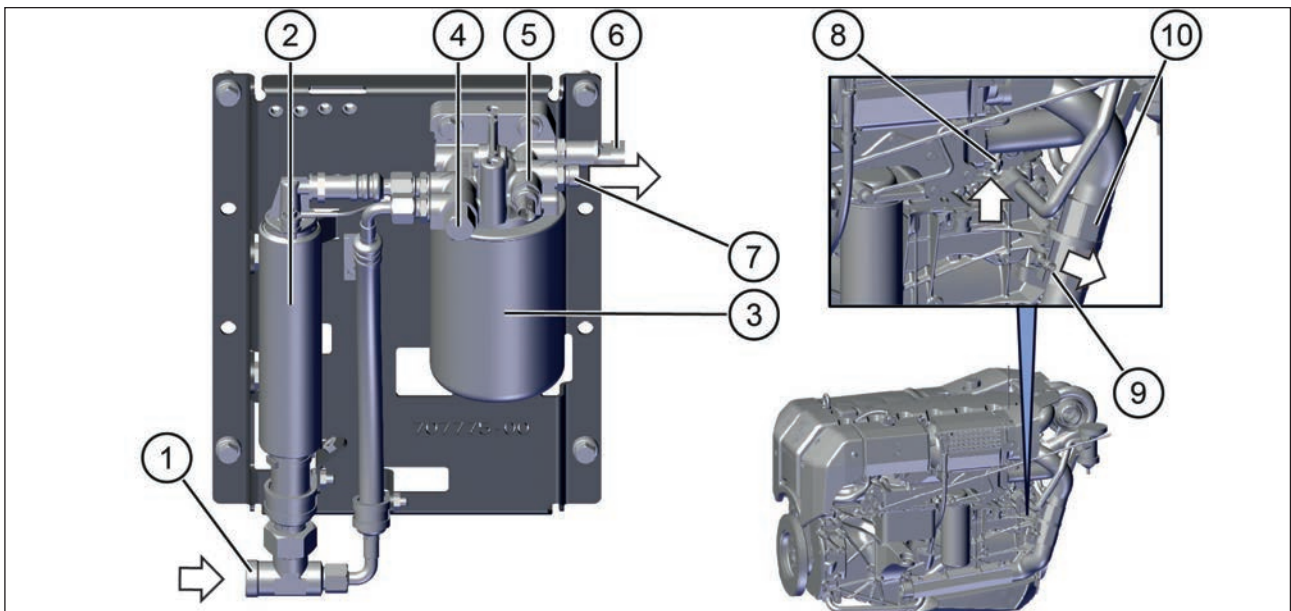

Fig. 37

Item	Description
(1)	Fuel inlet connection (from fuel pre-filter)
(2)	Electrical fuel pump
(3)	Fuel fine filter
(4)	Pressure relieve valve
(5)	Fuel temperature sensor
(6)	Fuel pressure sensor

Item	Description
(7)	Fuel outlet connection (to engine fuel inlet connection no. #8)
(8)	Engine fuel inlet connection
(9)	Engine fuel outlet connection (back to fuel tank)
(10)	Fuel cooler

All **Steyr Motors** Marine engines are tested and certified, and meet following regulations / certifications:

**Regulations:**

- IMO Resolution MSC. 81 (70) Testing of Lifesaving Appliances
- Regulation (EU) 2022/1157, item No. MED/1.36. SOLAS 74 as amended, Regulation III/4, III/34 & X/3 and LSA Code
- DNV standard DNV-ST-E406 - Design of free-fall lifeboats

**Certifications:**

- TYPE APPROVAL CERTIFICATE  
Steyr Motors Certificate No: TAM00000DY
- EC-TYPE EXAMINATION CERTIFICATE (MODULE B)  
Steyr Motors Certificate No: MEDB000034E
- QS - CERTIFICATE OF ASSESSMENT - EC (MODULE E)  
Steyr Motors Certificate No: MEDE000000M

In terms of the externally installed fuel system the boat builders have to consider following:

As there is a wide variety of applications in the marine sector it is in the responsibility of the boat builders to comply and to prove the application to the particular regulations (SOLAS, Lifeboat, etc.).

**Steyr Motors** cannot cover this variety of requirements and regulations with one fuel system. Therefore, some additional pre-measures must be done for each particular installation (e.g. splashguard, dip drain etc.) to fulfil the necessary regulations.

For this reason, a standardised, externally installed fuel system for the marine sector is supplied.

The fuel hoses supplied, including the fitted fittings, comply with the following standards:

- SAE J1527 Type A Class I, USCG SAE J1942, ISO 7840, USCH H, HF, German Lloyd, Lloyds RE.

According to the manufacturer's specifications, these hoses are permitted / approved for operation with the following media:

- Gasoline, ethanol blends, diesel fuels, petroleum base hydraulic fluids, and lubricating oils.

The system volume is approximately 1.2 litres without pre-filter.

## Operation

---

- [A] Basic position of externally mounted fuel system:  
The axis of the fuel filter head outlet connection (7) is to be mounted equal to or higher than the engine fuel inlet connection (9).

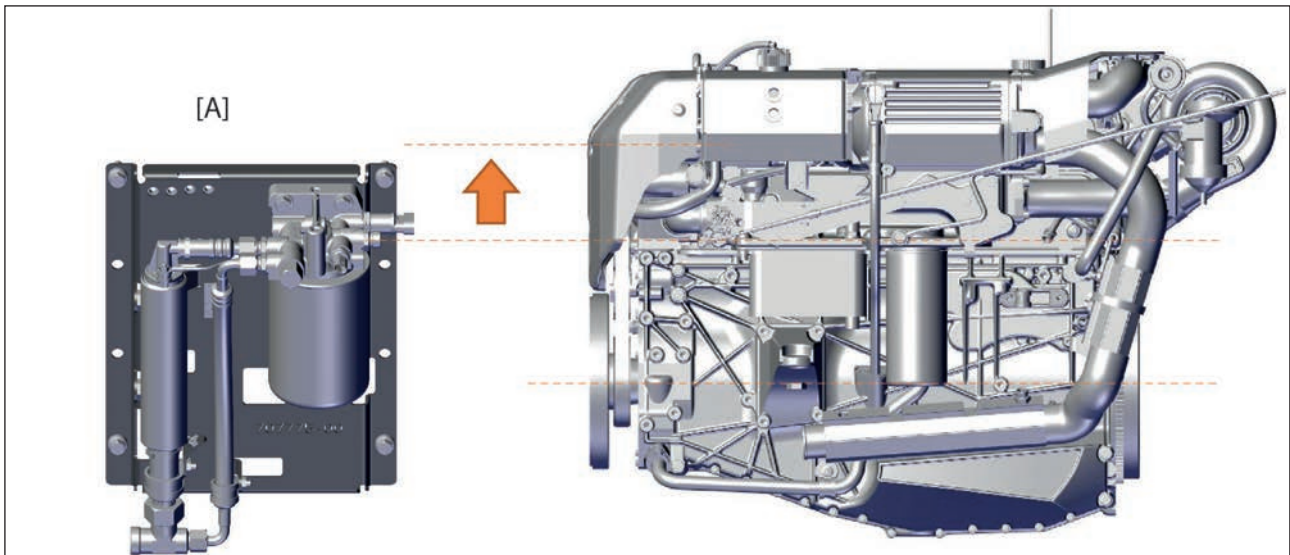

Fig. 38

## 1.21 Cooling system

**Steyr Motors** marine engines are equipped with a closed (internal) and an open (external) cooling circuit.

### 1.21.1 Function description: 6 cylinder engine

#### Closed cooling circuit

The closed cooling system consist of a pressurized circuit with an expansion tank. The pressurized circuit consists of coolant distribution manifold, monoblock coolant jacket, exhaust manifold with thermostat and heat exchanger. The system pressure is controlled by a pressure cap on the expansion tank. The level of coolant in the expansion tank differs between cold and warmed-up engine in a range of the min. & max. indicating marks. Temperature in the closed cooling circuit is controlled by means of thermostat. The thermostat determines the amount of coolant circulating through the heat exchanger, thus controlling the operating temperature of the engine.

A temperature sensor **(A)** checks the cooling temperature. An excessive temperature rise of the coolant will cause an optical and audible alarm (*see table 2.8 Error indication on instrument panel*). In this case, engine power will be reduced.

The temperature gauge on the instrument panel indicates the coolant temperature of the engine.

#### Open cooling circuit (Raw water circuit)

Thermal energy transferred from the engine and absorbed by the engine coolant is drained via the (external) raw water circuit. Raw water is sucked by the pump via the raw water intake, constantly pumped through intercooler and heat exchanger, and discharged together with the exhaust gas inside the exhaust elbow. In this passage the raw water exits through the exhaust pipe system.

A temperature sensor **(B)** monitors the raw water and exhaust gas mix temperature. An excessive rise will cause an optical and audible alarm (*see table 2.8 Error indication on instrument panel*). In this case, the engine power will be reduced.

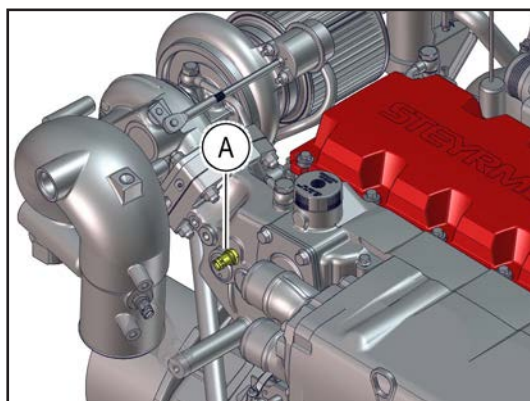

Fig. 39

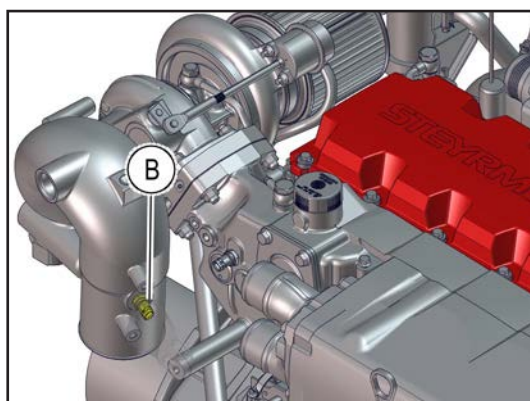

Fig. 40

### ***NOTICE***

Should the engine overheat at high speeds, reduce RPM to idling to prevent damages to the engine. In case of overheating problems, contact your **Steyr Motors** marine dealer.

In case of dry exhaust installation, contact your **Steyr Motors** marine dealer for exhaust temperature sensor positioning.

---

## 1.21.2 Function description: 4 cylinder engine

### Closed cooling circuit

The closed cooling circuit includes monoblock as well as exhaust manifold, heat exchanger and expansion tank. Temperature in the closed cooling circuit is precisely controlled by means of thermostat. The thermostat determines the amount of coolant circulating through the heat exchanger, thus controlling the operating temperature of the engine.

A temperature sensor **(A)** controls the cooling temperature. An excessive temperature rise of the coolant will cause an optical and audible alarm (*see table 2.8 Error indication on instrument panel*). In this case, engine power will be reduced.

The temperature gauge on the instrument panel indicates the coolant temperature of the engine.

### Open cooling circuit (Raw water circuit)

Thermal energy transferred from the engine and absorbed by the engine coolant is drained via the (external) raw water circuit. Raw water is sucked by the pump via the raw water intake, constantly pumped through intercooler and heat exchanger, and discharged together with the exhaust gas inside the exhaust elbow. In this passage the raw water exits through the exhaust pipe system.

A temperature sensor **(B)** monitors the raw water- and exhaust gas mix-temperature. An excessive rise will cause an optical and audible alarm (*see table 2.8 Error indication on instrument panel*). In this case, the engine power will be reduced.

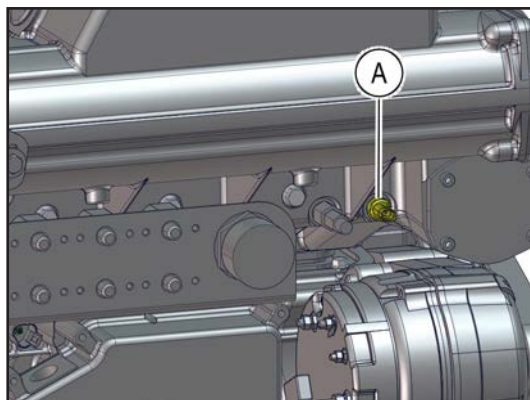

Fig. 41

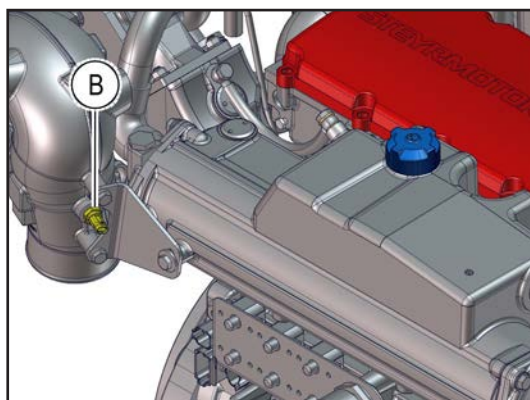

Fig. 42

## NOTICE

Should the engine overheat at high speeds, reduce RPM to idling to prevent damages to the engine. In case of overheating problems, contact your **Steyr Motors** marine dealer.

In case of dry exhaust installation, contact your **Steyr Motors** marine dealer for exhaust temperature sensor positioning.

### 1.22 Electrical equipment

The electrical equipment of your **Steyr Motors** marine engine primarily consists of an alternator with transistorized voltage regulator, battery and all necessary connecting cables and leads.

---

#### **NOTICE**

24 V on board system requires a specified DC/DC-converter to supply the entire Engine Management System EMS with 12 V. For detailed instructions consult your authorized **Steyr Motors** service partner.

---

#### 1.22.1 Alternator

The alternator is driven via a poly-v belt to charge the battery at all engine speeds. Output at idle speed is limited to low amperage/voltage values and will rise with maximum output occurring above an engine speed of 3000 rpm.

#### **Optional:**

Alternators are available with different outputs and voltages.

## 1.22.2 Battery

### For all 6 cylinder marine engines

Use a 12-volt battery with a cold testing circuit of 650 A at – 18 °C and a minimum capacity of 115 Ah at 27 °C, to ensure the supply of the electric and electronic components at all operating conditions.

### For all 4 cylinder marine engines

Use a 12-volt battery with a cold testing circuit of 450 A at – 18 °C and a minimum capacity of 92 Ah at 27 °C, to ensure the supply of the electric and electronic components at all operating conditions.

**ATTENTION:** \* **Do not use jumper cables and a booster battery to start engine. Remove battery from boat and recharge.**



- **WRONG CONNECTION WILL DESTROY ELECTRONIC SYSTEM**

\* **Do not charge battery in boat. Fumes vented during battery charging can lead to an explosion.**

\* **Battery electrolyte is a corrosive acid and should be handled with care.**

If electrolyte is spilled or splashed on any part of the body, immediately flush the exposed area with liberal amounts of water and obtain medical aid as soon as possible.

High resistance in the charging circuit can seriously affect the operation of the electrical system. Unless there is definite malfunction in the electrical system, high resistance is sometimes caused by corroded or loose connections. Wherever practical, the electrical connections on your engine have been sealed. However, we recommend that you make periodic inspections to ensure clean, tight connections throughout the electrical system.

---

## NOTICE

It is important that the battery connections are correct. The negative battery cable must be attached to the negative terminal (–) on the battery and the engine's positive cable must be attached to the positive terminal (+) on the battery. If these connections are reversed, the regulating unit may be immediately damaged.

---

Inspect your battery at regular intervals for specific gravity (state of charge), individual cell water level, cleanliness and clean, tight connections.

If the battery has become discharged for no apparent reason, check all electrical system components for malfunction, or a switch left in ON position prior to installing recharged battery.

## Operation

---

### 1.22.3 Circuit breakers & fuses 6 cylinder engines

**Steyr Motors** marine engine models are protected against overload by circuit breakers.

The base plate of the E-box carries 6 different thermal triggered circuit breakers.

Fuse protection level and function

F1	20 Amp fuse VBatt main relay
F2	25 Amp fuse fuel-pump circuit
F3	20 Amp fuse ECU circuits
F4	50 Amp fuse glow-plug circuit
F5	50 Amp fuse glow-plug circuit
F6	12.5 Amp fuse D+ alternator terminal

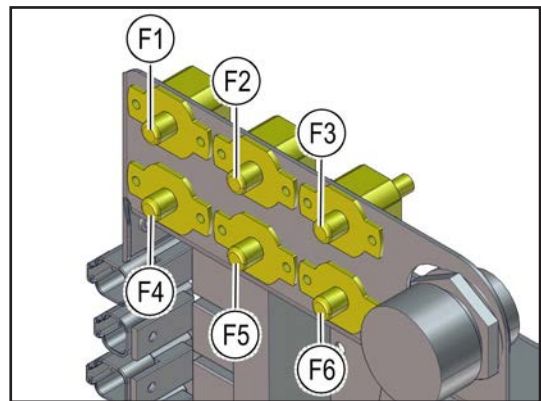

Fig. 43

---

### **NOTICE**

Avoid sparks that will damage the alternator or ECU. Do not attempt to connect or disconnect any part of the electrical system while the engine is running.

---

### **NOTICE**

The installation of any additional electrical accessories requires the protection of individual circuits. Consumption of current should occur directly at the battery.

---

### **NOTICE**

If the automatic electric circuit breaker is triggered more than ten times, a preventive replacement is recommended.

---

### 1.22.4 Circuit breakers & fuses 4 cylinder engines

**Steyr Motors** marine engine models are protected against overload by circuit breakers.

The base plate of the E-box carries 6 different thermal triggered circuit breakers.

Fuse protection level and function

F1	20 Amp fuse VBatt main relay
F2	25 Amp fuse fuel-pump circuit
F3	20 Amp fuse ECU circuits
F4	50 Amp fuse glow-plug circuit
F5	50 Amp fuse glow-plug circuit
F6	10 Amp fuse D+ alternator terminal

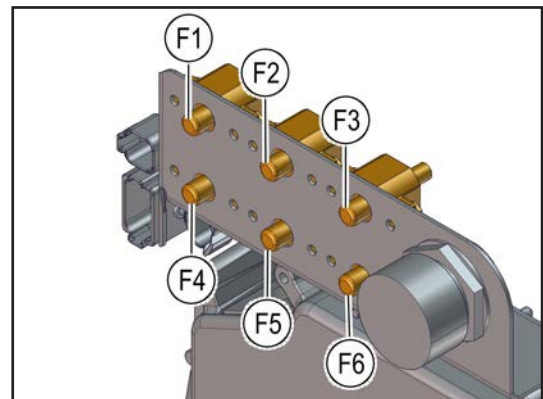

Fig. 44

#### **NOTICE**

Avoid sparks that will damage the alternator or ECU. Do not attempt to connect or disconnect any part of the electrical system while the engine is running.

#### **NOTICE**

The installation of any additional electrical accessories requires the protection of individual circuits. Consumption of current should occur directly at the battery.

#### **NOTICE**

If the automatic electric circuit breaker is triggered more than ten times, a preventive replacement is recommended.

### 1.22.5 Inversion switch (optional)

The inversion switch **(A)** which is activated in the case of an inclination of the boat in any direction over 70 °.

Via the main circuit relay the engine is shut down.

For safe guarding reasons the inversion switch must be checked according to the Service and Maintenance Schedule.

---

#### CAUTION

After such an event, this temporarily stored operating condition is to be cancelled from the engine management system by ignition "OFF" = "Reset".

Without "Reset", a new start of the engine is not possible.

---

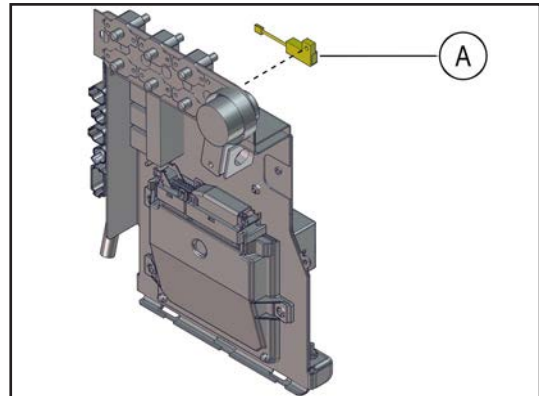

Fig. 45

### 1.22.6 Interrupt crankshaft housing ventilation (optional)

During possible vessel inversion, the by-pass valves **(B, C)** for crankshaft housing ventilation is closed.

This avoids a possible oil outlet via suction through the air filter.

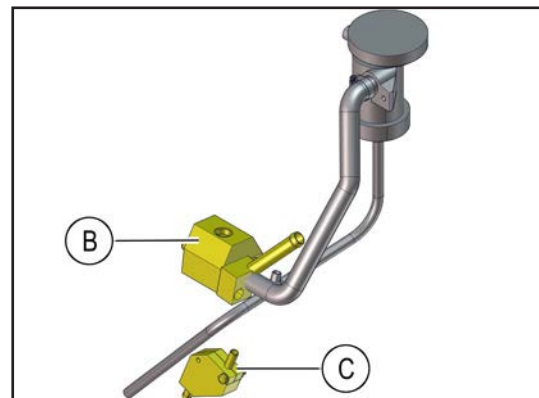

Fig. 46

### 1.22.7 Instrument panel

The engines are supplied with the standard instrument panel.

The respective customer may use a self-adapted **Steyr Motors** instrument panel or one which corresponds to his own ideas and requirements.

---

#### CAUTION

For unapproved alterations which lead to engine failure, no liability can be undertaken.

---

### 1.22.8 Dry operation

After a dry operation of the engine (without raw water cooling), check the impeller of the raw water pump for damages. Replace if necessary. Grease the impeller, use grease from genuine impeller service kit (see adequate spare parts catalogue).

## 1.23 Storage preservation procedure

If the engine will not be in use for a longer period of time, the engine needs to be preserved to avoid possible damage to the engine.

## 1.24 Startup after storage

When commissioning or running an engine that has been preserved, the engine will run roughly and smoke for the first few minutes. Do not be alarmed as this is normal until the deposits of the preservation materials have cleared

### 1.25 Fill fuel

#### **NOTICE**

##### **Possible engine damage due to contaminated fuel!**

The fuel system and the engine can be damaged by dirt particles or other contamination in the fuel, therefore:

- ▶ Only fill with clean diesel fuel according to EN 590 or F54. See chapter **“B 1 Fuel requirements”** for detailed information.
- ▶ Pay attention to cleanliness so that no dirt gets into the fuel tank or any fuel connection parts.
- ▶ The engine/vessel must stand upright for filling of fuel.

---

#### **i** Information

For the exact position of the filler neck refer to the operator manual of the vessel manufacturer.

---

Fuel supply to the engine:

The image shows the fuel inlet connection **(1)** to the engine block.

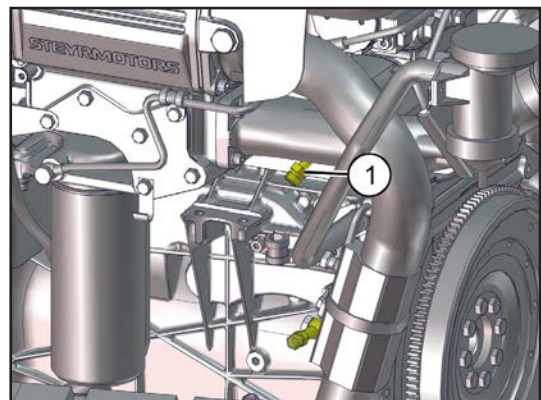

Fig. 47

Fuel from engine:

The image shows the fuel outlet connection **(2)** from the engine block.

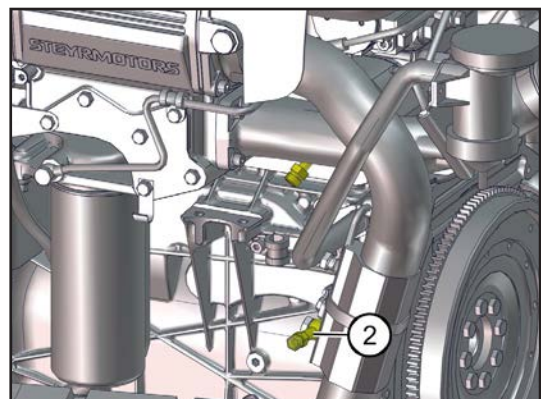

Fig. 48

## 1.26 Fill engine oil

### CAUTION

Using the incorrect engine oil can cause hazards or engine damages.

- ▶ Use engine oil according to the specification in chapter **B 2 Engine oil requirements**.
- ▶ Observe the material safety data sheet.

### CAUTION

Pay attention to hot engine oil. The temperature of engine oil can reach temperatures of 135 °C.

Hot surfaces and hot oil can cause serious injury.

- ▶ Use engine oil according to the specification in chapter **B 2 Engine oil requirements**.
- ▶ Observe the material safety data sheet.
- ▶ Avoid contact with hot engine.

1. Bring the engine to operating temperature and stop the engine. Wait approx. two minutes for the oil to collect in the engine oil pan.
2. Pull out oil dipstick (1).
3. Clean the oil dipstick with a fluff-free cloth at the measurement area and insert the dipstick.
4. Pull out the oil dipstick again.

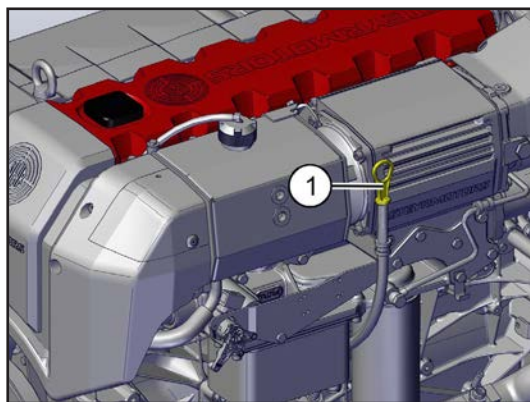

Fig. 49

5. Check the correct engine oil level. The oil level must be between the MIN and MAX marks at the oil dipstick.
6. Top up if necessary. For the correct specification see chapter "**B 2 Engine oil requirements**".

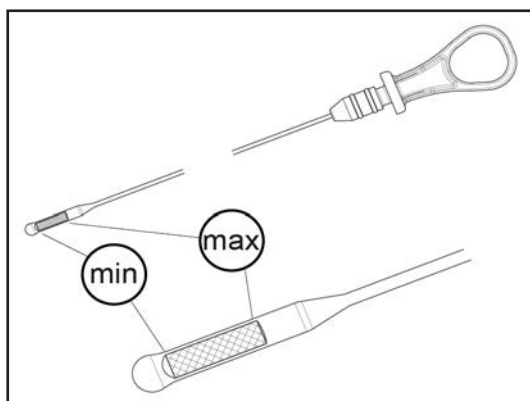

Fig. 50

## Operation

---

7. For refilling remove the oil filler cap **(1)**.
8. Fill in engine oil of the correct specification.
9. Put on oil filler cap **(1)** and lock by hand.
10. Remove possible contamination from the oil filler cap and environment.

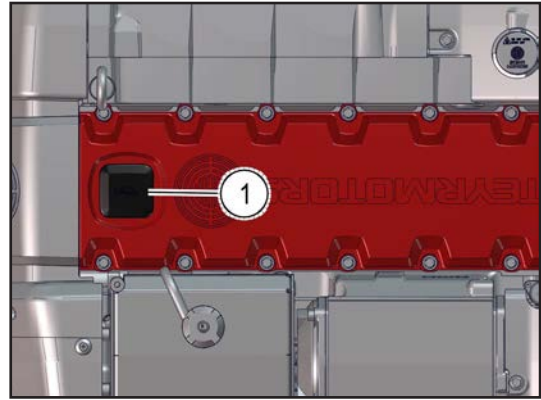

Fig. 51

---

### **NOTICE**

**Oil filling must be between the min. and max. markers of the oil dipstick.**

Lack of engine oil results in high operating temperatures, loss in efficiency, and a reduced engine life, overfilling additionally results in foaming of the engine oil (air in engine oil).

- ▶ Check oil level before starting the engine.
- ▶ Check oil level again after a test run of the engine.
- ▶ Engine/vessel must stand upright for checking the oil level.

---

t

---

## 1.27 Check and refill coolant

---

### CAUTION

**Coolant can damage organs through prolonged or repeated exposure.**

Contact with coolant can cause serious eye irritation.

- ▶ Do not inhale vapours.
  - ▶ Do not swallow coolant.
  - ▶ Avoid contact with eyes, to prevent eye damage.
  - ▶ Wear the appropriate personal protective equipment!
  - ▶ Observe the material safety data sheet.
- 

### CAUTION

**Using the incorrect coolant can cause hazards or engine damages.**

- ▶ Use coolant according to the specification **B 3 Engine coolant requirements**.
  - ▶ Observe the material safety data sheet.
- 

### WARNING

**With hot engine, the closed cooling circuit is under pressure. Do not try to open the pressure cap on the expansion tank or any drain plug or hoses of the coolant system.**

This may lead to severe injuries by hot coolant under pressure.

- ▶ Wait until the engine has cooled down, then open the pressure cap by  $\frac{1}{4}$  turn to the left to release the remaining system pressure.
  - ▶ Never open drain plugs or hose clamps at the cooling system with the engine at operating temperature.
-

## Operation

1. Check the engine coolant level at the expansion tank (1). For the exact position of the expansion tank at the vessel refer to the operator manual of the vessel manufacturer. The engine coolant level should be between the MIN (3) and MAX (4) marks of the expansion tank.

**Figure on the right is just an example.**

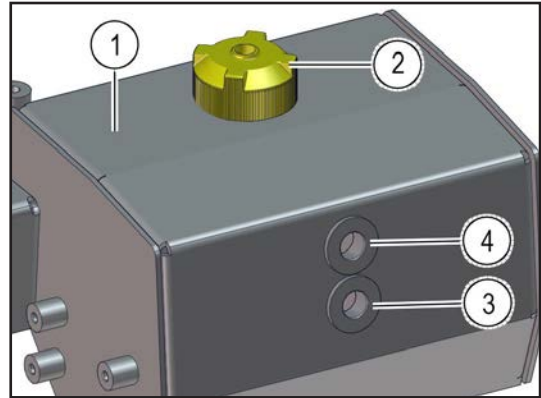

Fig. 52 example

2. Top up if necessary. Open filler cap (2). Fill the cooling circuit with specified coolant only, refer to chapter Engine Coolant Requirements for the correct specification. The engine coolant level must be between the MIN (3) and MAX (4) marks of the expansion tank.
3. Close the filler cap (2) properly.

**Figure on the right is just an example.**

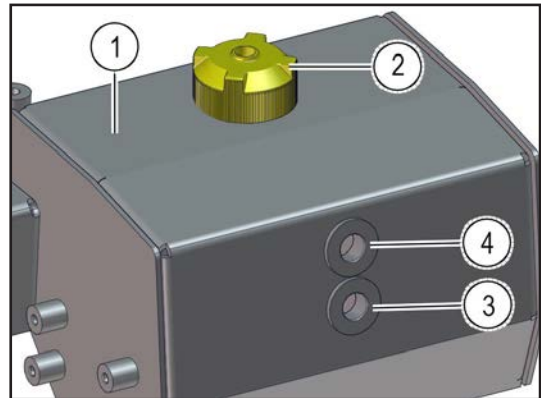

Fig. 53 example

## 2 Maintenance and service

### 2.1 Foreword

On receipt of your new **Steyr Motors** marine engine, the authorised dealer should have registered your engine at the **Steyr Motors** factory and reconfirmed this to you.

Future service requirements are indicated in “**2.4 Service and maintenance schedule**”. When these services are carried out, the **Steyr Motors** marine dealer will stamp the respective stubs. This servicing will assist in maintaining the value and satisfactory operation of your **Steyr Motors** marine engine.

It lies in the owner’s interest that for maintaining warranty and best performance of his **Steyr Motors** marine engine, we always insists on the sole utilization of **Steyr Motors** - ORIGINAL replacement parts, operating fluids and lubricants as well as **Steyr Motors** approved service procedures!

It is important that you study this chapter carefully as it will assist you in achieving satisfaction from your Steyr Motors marine engine.

Please retain this manual in the boat as it **MUST** be presented to the Steyr Motors marine dealer whenever you require **WARRANTY** and/or **SERVICE**.

### Important note

This chapter contains all service activities required for your engine. Checks and maintenance for the other parts of a complete drive system still need to be completed. Any such procedures are to be found in separate, attached booklet(s) of the individual manufacturer’s literature provided with the gearbox or similar drive components.

Whenever this manual refers to components like Manual Operation, Hydraulic Pump, etc., such instructions only apply where applicable since they are not used on every engine model.

## 2.2 Trouble check chart



### CAUTION

After following the "Action" described in the chart, and before cranking the engine, make sure that there are no loose fuel connections. Make sure the engine compartment is free of fuel vapours.

- ▶ Failure to comply could result in fire.
- ▶ Failure to comply could result in minor or moderate injury.

SYMPTOM	POSSIBLE CAUSE	ACTION
Engine won't start	<ol style="list-style-type: none"> <li>1. No fuel in tank or shut-off valve closed</li> <li>2. Air leak in suction lines</li> <li>3. Fuel line plugged or pump defective</li> <li>4. Poor fuel quality</li> <li>5. Water in fuel filter</li> </ol>	<p>Fill tank or open valve.</p> <p>Bleed fuel system and check for leaks.</p> <p>Fuel supply pump may be defective. See your Steyr Motors marine dealer.</p> <p>Replace fuel.</p> <p>Replace or drain water from fuel filter. Check fuel supply for water contamination. If water is present, drain fuel tank and flush with fresh fuel.</p>
Only for SOLAS ==>	<ol style="list-style-type: none"> <li>6. System error or failure</li> <li>7. Battery output insufficient</li> <li>8. Inversion switch actuated</li> </ol>	<p>Check engine management system display for service code.</p> <p>Charge or replace battery.</p> <p>Cancelled by ignition "OFF - ON"</p>



## Maintenance

SYMPTOM	POSSIBLE CAUSE	ACTION
Performance loss	<ol style="list-style-type: none"> <li>1. System error or failure</li> <li>2. Boat overloaded</li> <li>3. Boat trim</li> <li>4. Excessive water in bilge</li> <li>5. Boat hull condition</li> <li>6. Improper propeller selection</li> <li>7. Fuel incorrect</li> <li>8. Throttle not fully open</li> <li>9. Overheating</li> <li>10. Air intake troubles</li> </ol>	<p>Check: using diagnostics for errors or limitations. Engine coolant temperature; audible and or visual alarms.</p> <p>Reduce load.</p> <p>Distribute boat load evenly. Adjust trim.</p> <p>Drain bilge.</p> <p>See your Steyr Motors marine dealer.</p> <p>Select proper propeller pitch and diameter.</p> <p>Fill tank with correct fuel. Check fuel filter and fuel flow condition.</p> <p>Check throttle command lever for full travel.</p> <p>Check cooling system. Remove debris from water intake. Check belt tension. Check condition of impeller. Check for clogged heat exchanger tubing (in raw water circuit).</p> <p>Check intake air filter. Check ventilation of engine compartment.</p>
Excessive free play in steering wheel	Steering cable loose	See your Steyr Motors marine dealer.
High shift effort	<ol style="list-style-type: none"> <li>1. Remote control or transom bracket shift cable</li> <li>2. Remote control binding</li> <li>3. Engine/drive mechanism binding</li> </ol>	<p>Replace and adjust. See your Steyr Motors marine dealer.</p> <p>See your Steyr Motors marine dealer.</p> <p>See your Steyr Motors marine dealer.</p>

## 2.3 General fault finding chart

GENERAL FAULT FINDING CHART		Symptoms																								
		Starter/ISG does not rotate	Significant amount of white exhaust smoke	Black smoke	Little exhaust smoke	No exhaust smoke	Low engine power output	Abnormal fuel or engine oil consumption	No compression pressure feel when turning crankshaft	No pressure at unit injector	No fuel supply pressure when fuel supply pump ON	High speed/frequency running of electric fuel supply pump (high pitched noise)	ITD not keeping position	Low compression	No power to engine or start switch	Difficult starting	High blow-by values	Unstable engine running	Incorrect start of fuel-delivery	Excessive discharge of coolant	Overheating coolant system	Leak of gasket, exhaust manifold, cylinder	Leaking copper-insert or O-ring	Leaking oil cooler	O-ring of unit injector	
Factor, cause of trouble																										
Electrical system	Low battery	●																								
	Connection failure/terminal/main cable	●													●											
	Battery main switch not connected	●													●											
	Defective start switch	●																								
	Defective starter magnetic switch	●																								
	Breakdown of starter/ISG	●																								
	Fuse blown on ignition circuit	●																								
	Emergency cutoff switch interrupted	●																								
	Breakdown of glow plug		●																							
Fuel system	Running out of fuel					●				●	●	●														
	Clogging of fuel filter or water separator				●		●	●		●	●	●														
	Breakdown of fuel feed pump				●	●	●	●		●	●	●				●										
	Air trapped inside of the fuel system				●		●			●	●	●				●		●								
	Clogging of the fuel piping before fuel supply pump					●				●	●	●														
	Faulty injector nozzle		●	●	●		●	●											●							
	Incorrect setting of injection timing		●	●			●	●											●	●						
	Breakdown of injection pump				●	●	●	●																		
	No hydraulic pressure to build up				●		●	●								●		●								
	Stuck unit injector - spring remains compressed						●	●								●										
Others	Faulty driven machinery	●							●																	
	Clogging of air filter			●			●	●											●							
	High viscosity of engine oil																	●								
	Damage (seizure) of engines rotational/receiving parts	●							●									●	●							
	Faulty valve clearance		●				●	●	●										●							
	Low compression pressure		●				●	●	●									●	●							
	Faulty valve timing or engine timing		●				●	●	●									●	●							
	Faulty valve train		●	●	●		●	●	●							●										
	Faulty injection timing						●																			
	Air in coolant system														●						●	●				
	Fuel in coolant																						●	●		
	Coolant in lubricant																								●	
	Fuel in lubricant																								●	●
	Lubricant in coolant																								●	

● = critical  
● = non critical

## 2.4 Service and maintenance schedule

SE Service- and Maintenance Schedule				daily	after first 50 hours or 6 months	every 300 h. or 12 months	every 600 h. or 24 months	notes
Series SE 6 Cylinder (Z026168-0_13) (only for fuel according to EN 590)								
<b>Engine Lubrication</b>	check	- for leakage	O	●				
		- oil level	O	●				
	change	- oil filter	S		●	●		
		- engine oil	S		●	●		
<b>Engine Cooling System</b>	check	- for leakage	O	●				
		- fluid level	O	●				
		- hoses, hose clamps	O	●				
		- antifreeze temperature condition	O		●	●		
	change	- antifreeze	S					every 3600 hours or every 48 months
<b>Raw Water System</b>	check	- hoses, hose clamps	S	●				
		- zinc anodes	S		●			periodically
		- impeller	S			●		extreme environmental conditions (polluted water) halve the interval; if required, change impeller
	clean	- intercooler	S					every 900 hours or every 48 months
	change	- zinc anodes	S					if sacrificial progress reaches a material corrosion of 50 %
	preserve	- raw water circuit	S			●		after season
<b>Raw Water Cooler (Fuel, Hydraulic oil)</b>	check	- raw water passages	S			●		clean out deposits in pipelines
<b>Air Filter</b>	check	- contamination	S	●				
	change	- air filter element	S				●	
	preserve	- air filter element	S					after season
<b>Fuel System</b>	check	- for leakage	S	●				
		- hoses	S		●	●		
		- prefilter	S					x <sub>1</sub>
		- water in fuel	S	●				x <sub>2</sub>
	change	- fuel filters	S		●	●		depends on fuel quality
		- prefilter	S		●	●		x <sub>3</sub> , depends on fuel quality
preserve	- fuel system	S					after season / when out of operation for 6 months or more	
<b>Battery</b>	check		S					check battery charge condition
<b>Electronics</b>	check	- connections	S					after season

SE Service- and Maintenance Schedule					after first 50 hours or 6 months	every 300 h. or 12 months	every 600 h. or 24 months	notes
Series SE 6 Cylinder (Z026168-0_13) (only for fuel according to EN 590)				<i>daily</i>				
<b>Electrical Equipment</b>	<i>check</i>	- connections	S		●	●		tighten loose connections. Renew cables, if required
		- insulation	S		●	●		
<b>Inversion Switch</b>	<i>check</i>	- switch	S			●		
	<i>change</i>	- switch	S					every 1800 hours or every 48 months
<b>Driving System</b>	<i>re-center</i>	- driving unit	S		●	●		x <sub>1</sub>
<b>Turbo charger</b>	<i>check</i>	- actuation	S			●		
	<i>lubricate</i>	- actuation	S					after season / when out of operation for 1 month or more
<b>Warning Device</b>	<i>check</i>	- function	S	●				safety relevant
<b>Engine Mount Screws</b>	<i>check</i>	- torque	S		●			every 900 hours
<b>Safety Equipment</b>	<i>check</i>	- remote control	S	●				local rules and consultation of your Steyr Motors dealer
		- emergency cutout	S	●				
		- completeness	S	●				
	<i>change</i>	- emergency cutout	S					every 1800 hours or every 48 month
<b>Poly-V Belt</b>	<i>check</i>	- belt, pulleys and tighteners for wear	S		●	●		
	<i>change</i>	* poly-v belt system with standard equipment e.g.: alternator, raw water pump and hydraulic pump	S					every 1800 hours or every 48 months
		** poly-v belt system with optional equipment e.g. 2 <sup>nd</sup> additional alternator, high power hydraulic pump etc.	S					every 900 hours or every 48 months
<b>Poly-V Belt Tensioner</b>	<i>check</i>	-	S		●	●		
<b>Glow Plugs</b>	<i>change</i>	- plugs	S					every 1800 hours or every 48 months
<b>Timing Belt</b>	<i>check</i>	- belt tension	S		●	●		
	<i>change</i>	- timing belt	S					every 1800 hours or every 48 months
		- idler pulley (2x pieces)	S					
		- water pump	S					every 3600 hours or every 48 months
		- timing belt tensioner	S					
<b>Valves</b>	<i>check</i>	- valve clearance	S		●		●	
<b>Engine Timing</b>	<i>check</i>	- set timing	S		●		●	

## Maintenance

SE Service- and Maintenance Schedule					after first 50 hours or 6 months	every 300 h. or 12 months	every 600 h. or 24 months	notes
Series SE 6 Cylinder (Z026168-0_13) (only for fuel according to EN 590)				<i>daily</i>				
Unit Injector	check	- recalibrate levers setting	S		●		●	
		- set point	S		●		●	start of fuel deli- very
		- tightening torques	S		●		●	
clean	- unit injector	S				●	use tool SMO No. V00458 and follow enclosed instruc- tion 707090	
Hydraulic Pump (if fitted)	check	-oil level	S	●				
		-for leakage	S	●				
	change	- hydraulic oil	S				●	x <sub>1</sub>
Torsional Coupler	check	- tightness of bolts	S					every 48 months
	change	- bolts	S					if required, re- place bolts by us- ing Staloc 2S43
Front Vibration Damper	check	- tightening torque	S		●		●	
Engine Compartment and Bilge	check	- leakage water	S	●				repair or consult your Steyr Mo- tors dealer
		- leakage fuel	S	●				
		- leakage exhaust gas	S	●				
Shifting	check	- smooth action	S	●				
		- adjustment	S	●				
			O	for operating personnel				
			S	for service personnel				

x<sub>1</sub> refer to manufacturer specification / as per manufacturers guidelines.

x<sub>2</sub> drain/clean water from separator bowl.

Water separator is mandatory; check water separator daily

**NOTE:** Water in fuel can lead to accelerated fuel aging and other severe problems which can cause clogged fuel system parts [esp. filters]

x<sub>3</sub> if no pre-filter-manufacturer specifications available: change after first 50 hours; then after every 300 hours or minimum every year

### NOTICE

Operation at extreme environmental conditions may shorten the intervals. Any optical defect requires change of the component.

<b>SE Service- and Maintenance Schedule</b>					after first 25 hours or 3 months	every 150 h. or 6 months	every 300 h. or 12 months	notes
Series SE 6 Cylinder (702117_04) (valid for engines equipped with kit fuel density and fuel <b>not according to EN 590</b> )				<i>daily</i>				
<b>Engine Lubrication</b>	<i>check</i>	- for leakage	O	●				
		- oil level	O	●				
	<i>change</i>	- oil filter	S		●	●		
		- engine oil	S		●	●		
<b>Engine Cooling System</b>	<i>check</i>	- for leakage	O	●				
		- fluid level	O	●				
		- hoses, hose clamps	O	●				
		- antifreeze temperature condition	O		●	●		
	<i>change</i>	- antifreeze	S					every 3600 hours or every 48 months
<b>Raw Water System</b>	<i>check</i>	- hoses, hose clamps	S	●				
		- zinc anodes	S		●			periodically
		- impeller	S				●	extreme environmental conditions (polluted water) halve the interval; if required, change impeller
	<i>clean</i>	- intercooler	S					every 900 hours or every 48 months
	<i>change</i>	- zinc anodes	S					if sacrificial progress reaches a material corrosion of 50%
	<i>preserve</i>	- raw water circuit	S			●		after season
<b>Raw Water Cooler (Fuel, Hydraulic oil)</b>	<i>check</i>	- raw water passages	S			●		clean out deposits in pipelines
<b>Air Filter</b>	<i>check</i>	- contamination	S	●				
	<i>change</i>	- air filter element	S				●	
	<i>preserve</i>	- air filter element	S					after season
<b>Fuel System</b>	<i>check</i>	- for leakage	S	●				
		- hoses	S		●	●		
		- prefilter	S					x <sub>1</sub>
		- water in fuel	S					x <sub>2</sub>
	<i>change</i>	- fuel filters	S		●	●		
		- prefilter	S		●	●		x <sub>3</sub>
<i>preserve</i>	- fuel system	S					after season / when out of operation for 6 months or more	
<b>Battery</b>	<i>check</i>		S					check battery charge condition
<b>Electronics</b>	<i>check</i>	- connections	S					after season

## Maintenance

SE Service- and Maintenance Schedule					after first 25 hours or 3 months	every 150 h. or 6 months	every 300 h. or 12 months	notes
Series SE 6 Cylinder (702117_04) (valid for engines equipped with kit fuel density and fuel <b>not</b> according to EN 590)				<i>daily</i>				
<b>Electrical Equipment</b>	<i>check</i>	- connections	S		●	●		tighten loose connections. Renew cables, if required
		- insulation	S		●	●		
<b>Inversion Switch</b>	<i>check</i>	- switch	S			●		
	<i>change</i>	- switch	S					every 1800 hours or every 48 months
<b>Driving System</b>	<i>re-center</i>	- driving unit	S		●	●		see manufacturers specifications
<b>Turbo Charger</b>	<i>check</i>	- actuation	S			●		
	<i>lubricate</i>	- actuation	S			●		after season / when out of operation for 1 month or more
<b>Warning Device</b>	<i>check</i>	- function	S	●				safety relevant
<b>Engine Mount Screws</b>	<i>check</i>	- torque	S		●			every 900 hours
<b>Safety Equipment</b>	<i>check condition</i>	- remote control	S	●				local rules and consultation of your Steyr Motors dealer
		- emergency cutout	S	●				
		- completeness	S	●				
	<i>change</i>	- emergency cutout						every 1800 hours or every 48 months
<b>Poly-V Belt</b>	<i>check</i>	- belt, pulleys and tighteners for wear	S		●	●		
	<i>change</i>	* poly-v belt system with standard equipment e.g.: alternator, raw water pump and hydraulic pump	S					every 1800 hours or every 48 months
		** poly-v belt system with optional equipment e.g.: 2 <sup>nd</sup> additional alternator; high power hydraulic pump etc.	S					every 900 hours or every 48 months
<b>Poly-V Belt Tensioner</b>	<i>check</i>	-	S		●	●		
<b>Glow Plugs</b>	<i>change</i>	- plugs	S					every 1800 hours or every 48 months
<b>Timing Belt</b>	<i>check</i>	- belt tension	S		●	●		
	<i>change</i>	- timing belt - idler pulley (2x pieces)	S					every 1800 hours or every 48 months
		- water pump - timing belt tensioner	S					every 3600 hours or every 48 months
<b>Valves</b>	<i>check</i>	- valve clearance	S		●		●	
<b>Engine Timing</b>	<i>check</i>	- set timing	S		●		●	

SE Service- and Maintenance Schedule					after first 25 hours or 3 months	every 150 h. or 6 months	every 300 h. or 12 months	notes
Series SE 6 Cylinder (702117_04) (valid for engines equipped with kit fuel density and fuel <b>not</b> according to EN 590)				<i>daily</i>				
Unit Injector	check	- recalibrate levers setting	S		●		●	
		- set point	S		●		●	start of fuel delivery
		- tightening torques	S		●		●	
	clean	- unit injector	S				●	use tool SMO No. V00458 and follow enclosed instruction 707090
Hydraulic Pump (if fitted)	check	- oil level	S	●				
		- for leakage	S	●				
	change	- hydraulic oil	S				●	x <sub>1</sub>
Torsional Coupler	check	- tightness of bolts	S					every 48 months
	change	- bolts	S					if required, replace bolts by using Staloc 2S43
Front Vibration Damper	check	- tightening torque	S		●		●	
Engine Compartment and Bilge	check	- leakage water	S	●				repair or consult your Steyr Motors dealer
		- leakage fuel	S	●				
		- leakage exhaust gas	S	●				
Shifting	check	- smooth action	S	●				
		- adjustment	S	●				
			O	for operating personnel				
			S	for service personnel				

x<sub>1</sub> refer to manufacturer specification / as per manufacturers guidelines.

x<sub>2</sub> drain/clean water from water separator bowl.

Water separator is mandatory; check water separator daily

**NOTE:** Water in fuel can lead to accelerated fuel aging and other severe problems which can cause clogged fuel system parts [esp. filters]

x<sub>3</sub> if no pre-filter-manufacturer specifications available: change after first 25 hours; then after every 150 hours or minimum every year

## NOTICE

Operation at extreme environmental conditions may shorten the intervals. Any optical defect requires change of the component.

- The service life of some components depends on the fuel used. Depending on the fuel used, the service life may be reduced considerably!

## 2.5 Trouble indication chart (from year of manufacture 2021)

Instrument Panel Factors / Cause of trouble V30000	Effects noticed during operation						ECU / EMS			Help	
	Emergency cut off switch (Lanyard) connected / open (normal closed)	Battery charge light	Oil pressure indication light (+ pre glow time indication)	CEL light - visual indication	Acoustic indication (horn)	Gauge visual indication	Engine power limited Beta limitation active (boat performance / velocity)	Beta limitation diagnostic	Service code memorized	Area to troubleshoot	Tools
Ignition key turned to "ON" position	o	c	⋆	⋆	⋆	"ON" cont.					
Ignition key "ON" + start position => engine not cranking	o	c	⋆	⋆	⋆	"ON" cont.					
Ignition key turned to "ON" position, => missing CAN-data communication	o	c	⋆	⋆	⋆	OFF	no CAN-data on tacho				
Ignition key turned to "ON" position, => condition no service code stored	c	c	⋆	1 sec	1 sec	"ON" 1 sec		NO			
Ignition key turned to "ON" position, => condition no service code stored => pre-heating active (glow plugs)	c	c	⋆	cont. (2)	1 sec	"ON" 1 sec		NO			
Ignition key turned to "ON" position, (Service code memorized)	c	c	⋆	1 sec	5 sec	"ON" 5 sec		stored service code	Service code list	EDT	
Start => engine not cranking	c	o	⋆	⋆	⋆	OFF					
Start => running engine idle & charging	c	c	⋆	⋆	⋆	OFF					
ACT: high air charge temperature	c		⋆	⋆	2x/sec	"ON" 2x/sec	YES	2		Raw water circuit air charging system	
ACT: defective - air charge temperature sensor => or sensor connection	c		⋆	⋆	2x/sec	"ON" 2x/sec	YES above 800 rpm	2	274 / 275	Service code list	Sensor box
ECT: high engine coolant temperature => operation limit exceeded	c		⋆	⋆	1x/sec	"ON" 1x/sec	YES	64		Coolant circuit	
ECT: defective - engine coolant temperature sensor => or sensor connection	c		⋆	⋆	1x/sec	"ON" 1x/sec	YES (4)	64	279 / 280	Service code list	Sensor box
EXT: high exhaust coolant temperature => operation limit exceeded	c		⋆	⋆	2x/sec	"ON" 2x/sec	YES	2048		Raw water circuit	
EXT: defective - exhaust coolant temperature sensor => or sensor connection	c		⋆	⋆	2x/sec	"ON" 2x/sec	YES above 800 rpm	2048	1029 / 1030	Service code list	Sensor box
LPS: low oil pressure => lubricant pressure below limit	c		⋆	1x/sec	⋆	"ON" cont.	YES	8		Pressurized lubricant system	
LPS: defective lubricant pressure sensor => or sensor connection	c		⋆	⋆	⋆	OFF	YES above 2650 rpm	8	1314 / 1315	Service code list	Sensor box
MAP: insufficient boost pressure (at given load & speed) => or defective sensor => or sensor connection	c		⋆	⋆	⋆	OFF	YES above 1175 rpm	4	263 / 264 (5)	Combustion system, charging system	Sensor box,
RPM: defective - engine speed sensor => or sensor connection	c		⋆	⋆	⋆	OFF	no RPM on tacho	Engine stops running	1829 / 1832 (6)	Speed sensor, trouble shooting procedure	Sensor box
RPOS: defective rack position sensor => or sensor connection	c		⋆	⋆	⋆	"ON" cont.	YES		594	Electrical system	Sensor box
RPOS: RPOS deviation (rack blocked)	c		⋆	⋆	⋆	"ON" cont.	YES		594	Rack, actuator	
ITD: ITP deviation	c		⋆	⋆	⋆	OFF	YES	1024	4113	Injection timing device, lubricant system	
ITD: defective ITP sensor => or sensor connection	c		⋆	⋆	⋆	OFF	YES	1024	4097 / 4098 / 4113	Service code list	
FPS: fuel pressure is too low (below > 2.0 bar for min. 10 sec)	c		⋆	⋆	4s/1 Hz on & 4s off	OFF			395	Service code list	EDT 2.0
SOLAS: inversion switch active	c		⋆	⋆	⋆	"ON" cont.			NO		
MET / T30: defective - manifold exhaust gas temp. sensor => or sensor connection (3)	c		⋆	⋆	⋆	OFF	YES	4096	1349 / 1350	MET sensor	
MET / T30: high manifold exhaust gas temperature => operation limit exceeded (3)	c		⋆	⋆	⋆	OFF	YES	4096		Fuel density, combustion system	
FDS: defective - fuel density sensor => or sensor connection => or fuel density out of range (3)	c		⋆	⋆	⋆	OFF	YES		345 / 375 / 377	FDS sensor, fuel density	
WIF: water in fuel sensor (option) => too much water in the separator	c		⋆	⋆	⋆	⋆	NO		8809	Empty water separator	
Others											
No charging from alternator (7)	c		⋆	⋆	⋆	OFF	NO		NO	Electrical system, belt drive	
Limitation during "Break in" phase	c		⋆	⋆	⋆	"ON" cont.	NO		NO		

(1) Hz  $f = \frac{1}{T}$   
 f = frequency [Hz]  
 T = time of oscillation [s]

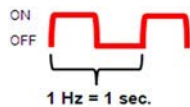

- (2) light remains active during pre-heating process; activation and duration determined by engine temp.
- (3) only in combination with FDS (fuel density sensor)
- (4) no limitation below 1000 rpm; limitation above 1000 rpm after 180 sec.; limitation above 2000 rpm
- (5) limitation due to insufficient boost may occur without faultcode; 263 and 264 are served for defective sensor or sensor connection.
- (6) no tacho RPM, or engine start can occur without faultcode; 1829 and 1832 are served for defective speed sensor or speed sensor connection
- (7) direct connection to alternator; error codes 1378 and 1379 set only by voltage measured at the ECU supply

## 2.6 Trouble indication chart (until year of manufacture 2020)

Instrument Panel Factors / Cause of trouble V50000	Effects noticed during operation						ECU / EMS				Help	
	Emergency cut off switch (Lanyard) connected / open normal closed	Battery charge light	Oil pressure indication light (+ pre glow time indication)	CEL light - visual indication	Acoustic indication (horn)	Gauge visual indication	Engine power limited Beta limitation active (boat performance / velocity)	Beta limitation diagnostic	Service code memorized	Area to troubleshoot	Tools	
Ignition "ON" => starting	Ignition key turned to "ON" position	o	c	*	*	*	"ON" cont.					
	Ignition key "ON" + start position => engine not cranking	o	c	*	*	*	"ON" cont.					
	Ignition key turned to "ON" position, missing CAN-data communication	o	c	*	*	*	OFF	no CAN-data on tacho				
	Ignition key turned to "ON" position, (condition no service code stored)	c	c	*	*	*	"ON" 1 sec		NO			
	Ignition key turned to "ON" position, (Service code memorized)	c	c	*	*	*	"ON" 1 sec		Stored service code	Service code list	EDT	
	Start => engine not cranking	c	o	*	*	*	OFF					
Start => running engine idle & charging	c	c	*	*	*	OFF						
Possible indication during operation	ACT: high air charge temperature => operation limit exceeded	c		*	*	*	"ON" 2 x p. sec	2	YES	Raw water circuit charging system		
	ACT: defective - air charge temperature sensor => or sensor connection	c		*	*	*	"ON" 2 x p. sec	2	YES above 800 rpm	274 / 275	Service code list	Sensor box
	ECT: high engine coolant temperature => operation limit exceeded	c		*	*	*	"ON" 2 x p. sec	64	YES	64	Coolant circuit	
	ECT: defective - engine coolant temperature sensor => or sensor connection	c		*	*	*	"ON" 2 x p. sec	64	YES (4)	279 / 280	Service code list	Sensor box
	EXT: high exhaust coolant temperature => operation limit exceeded	c		*	*	*	"ON" 2 x p. sec	2048	YES	2048	Raw water circuit	
	EXT: defective - exhaust coolant temperature sensor => or sensor connection	c		*	*	*	"ON" 2 x p. sec	2048	YES above 800 rpm	1029 / 1030	Service code list	Sensor box
	LPS: low oil pressure => lubricant pressure below limit	c		*	*	*	"ON" cont.	8	YES	8	Pressurized lubricant system	
	LPS: defective lubricant pressure sensor => or sensor connection	c		*	*	*	OFF	8	YES above 2650 rpm	1314 / 1315	Service code list	Sensor box
	MAP: insufficient boost pressure (at given load & speed) => or defective sensor => or sensor connection	c		*	*	*	OFF	4	YES above 1175 rpm	8744 / 8745 (5)	Combustion system, charging system	Sensor box
	RPM: defective - engine speed sensor => or sensor connection	c		*	*	*	OFF	no RPM indication on tacho	Engine stops running	1829 (6)	Speed sensor, trouble shooting procedure	Sensor box
	RPOS: defective rack position sensor => or sensor connection	c		*	*	*	"ON" cont.	YES	594 / 600 / 601	Electrical system	Sensor box	
	RPOS: RPOS deviation (rack blocked)	c		*	*	*	"ON" cont.	YES	594	Rack, actuator		
	ITD: ITP deviation	c		*	*	*	OFF	1024	YES	4113	Injection timing device, lubricant system	
	ITD: defective ITP sensor => or sensor connection	c		*	*	*	OFF	1024	YES	4097 / 4098 / 4113	Service code list	
FPS: fuel pressure is too low (below > 2.0 bar for min. 10 sec) Note: implemented with software V50000.11B.XXXXX	c		*	*	*	OFF			4s on & 4s off (2)	395	Service code list	EDT 2.0
Optional equipment	SOLAS: inversion switch active	c		*	*	*	"ON" cont.			NO		
	MET / T30: defective - manifold exhaust gas temp. sensor => or sensor connection (3)	c		*	*	*	OFF	4096	YES	1349 / 1350	MET sensor	
	MET / T30: high manifold exhaust gas temperature => operation limit exceeded (3)	c		*	*	*	OFF	4096	YES	4096	Fuel density, combustion system	
	FDS: defective - fuel density sensor => or sensor connection => or fuel density out of range	c		*	*	*	OFF		YES	374 / 375	FDS sensor, fuel density	
WIF: water in fuel sensor (option) => too much water in the separator	c		*	*	*	4s on & 4s off (2)	4s on & 4s on (2)	NO		8805	Empty water separator	
Others	No charging from alternator	c		*	*	*	OFF	NO		NO	Electrical system, belt drive	
	Limitation during "Break in" phase	c		*	*	*	"ON" cont.	NO		NO		

(1) Hz  $f = \frac{1}{T}$   
 f = frequency [Hz]  
 T = time of oscillation [s]

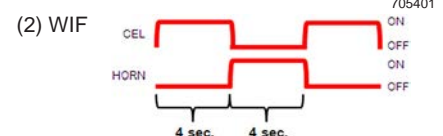
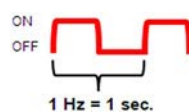

(3) only in combination with FDS (fuel density sensor)

(4) no limitation below 1000 rpm; limitation above 1000 rpm after 180 sec.; limitation above 2000 rpm

(5) limitation due to insufficient boost may occur without faultcode; 8744 and 8745 are served for defective sensor or sensor connection.

(6) no tacho RPM, or engine start can occur without faultcode; 1829 and 1832 are served for defective speed sensor or speed sensor connection



<b>1200 h Service</b>
<i>Made by:</i>
<i>Date:</i>

<b>1350 h Service</b>
<i>Made by:</i>
<i>Date:</i>

<b>1500 h Service</b>
<i>Made by:</i>
<i>Date:</i>

<b>1650 h Service</b>
<i>Made by:</i>
<i>Date:</i>

<b>1800 h Service</b>
<i>Made by:</i>
<i>Date:</i>

<b>1950 h Service</b>
<i>Made by:</i>
<i>Date:</i>

<b>2100 h Service</b>
<i>Made by:</i>
<i>Date:</i>

<b>2250 h Service</b>
<i>Made by:</i>
<i>Date:</i>

<b>2400 h Service</b>
<i>Made by:</i>
<i>Date:</i>

<b>2550 h Service</b>
<i>Made by:</i>
<i>Date:</i>

<b>2700 h Service</b>
<i>Made by:</i>
<i>Date:</i>

<b>2850 h Service</b>
<i>Made by:</i>
<i>Date:</i>

## 2.8 Error indication on instrument panel

### Instrument panel (standard)



Fig. 54

- |   |  |
|---|--|
| <b>A</b> Audible warning device         | <b>C</b> Combined light preheating control & warning light engine oil pressure |
| <b>B</b> Warning light - battery charge | <b>D</b> Warning light CEL check engine lamp                                   |

**Operating condition:** During normal engine operation, or indication in case of sensor defect while ignition is switched ON.

**Event:** Speed resp. performance limitation during engine operation

## Instrument panel (SOLAS)



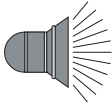







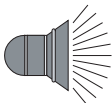

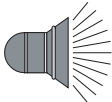



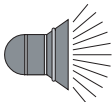



Fig. 55











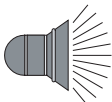

- |   |  |
|---|--|
| <b>A</b> Audible warning device         | <b>C</b> Combined light preheating control & warning light engine oil pressure |
| <b>B</b> Warning light - battery charge | <b>D</b> Warning light CEL check engine lamp                                   |

**Operating condition:** During normal engine operation, or indication in case of sensor defect while ignition is switched ON.



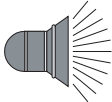







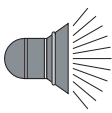





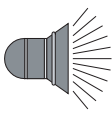

**Event:** Speed resp. performance limitation during engine operation

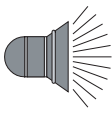



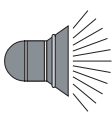





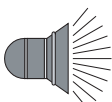

## Maintenance

Indication status V30000 (valid for engines from year of manufacture 2021)			Fault	Remarks
80 ° - 90 °C  <b>ON</b> 	  	<b>ON</b>  <b>FLASH- ING (1x per sec.)</b>  <b>OFF</b>	Oil pressure below min. limit	Check oil level, contact authorized workshop
80 ° - 90 °C  <b>OFF</b> 	  	<b>OFF</b>  <b>ON</b>  <b>OFF</b>	Fault oil pressure sensor or sensor connection	Check oil level, contact authorized workshop
<b>ON</b> 		<b>ON</b>	Engine overload during break-in period	Reduce throttle position until light goes OFF (indication during first 2 hours of operation) see "engine break in procedure"
80 ° - 90 °C  <b>ON</b>  <b>(2x per sec.)</b>	  	<b>FLASH- ING (2x per sec.)</b>  <b>OFF</b>  <b>OFF</b>	<b>High exhaust temperature (over 85 °C) or defect exhaust tempe- rature sensor or bad connection</b>	Check raw water system, strainer, impeller pump contact authorized workshop
<b>high approx 105 °C</b>  <b>ON</b>  <b>(1x per sec.)</b>	  	<b>FLASH- ING (1x per sec.)</b>  <b>OFF</b>  <b>OFF</b>	<b>Engine coolant temperature too high</b>	After cooling down, check engine coolant level contact authorized workshop

Indication status V30000 (valid for engines from year of manufacture 2021)			Fault	Remarks
<b>120 °C</b>  <b>ON</b>  <b>(1x per sec.)</b>	  	<b>FLASH- ING (1x per sec.)</b>  <b>OFF</b>  <b>OFF</b>	Defect engine coolant sensor or bad connection	After cooling down, check engine coolant level Contact authorized workshop
<b>80 ° - 90 °C</b>  <b>OFF</b> 	  	<b>OFF</b>  <b>OFF</b>  <b>OFF</b>	Unstable idle speed, no indication on tachometer  	Defect speed sensor or sensor connection contact authorized workshop
<b>80 ° - 90 °C</b>  <b>ON</b> 	  	<b>ON</b>  <b>OFF</b>  <b>OFF</b>	Trouble in governing loop, involved components: control solenoid, rack, control gear of unit injector, rack position sensor	Contact authorized workshop

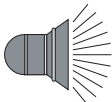
## Maintenance

Indication status V50000 (valid for engines until year of manufacture 2020)			Fault	Remarks
80 ° - 90 °C  <b>ON</b> 	  	OFF ON OFF	Oil pressure below min. limit	Check oil level, contact authorized workshop
80 ° - 90 °C  OFF 	  	OFF <b>FLASHING (1x per sec.)</b> OFF	Fault oil pressure sensor or sensor connection	Check oil level, contact authorized workshop
<b>ON</b> 		ON	Engine overload during break-in period	Reduce throttle position until light goes OFF (indication during first 2 hours of operation) see "engine break in procedure"
80 ° - 90 °C  <b>ON</b>  <b>(2x per sec.)</b>	  	<b>FLASHING (2x per sec.)</b> OFF OFF	<b>High exhaust temperature (over 85 °C) or defect exhaust temperature sensor or bad connection</b>	Check raw water system, strainer, impeller pump contact authorized workshop
<b>high approx 108 °C</b>  <b>ON</b>  <b>(2x per sec.)</b>	  	OFF OFF OFF	<b>Engine coolant temperature too high</b>	After cooling down, check engine coolant level contact authorized workshop

Indication status V50000 (valid for engines until year of manufacture 2020)			Fault	Remarks
<p>120 °C</p> <p><b>ON</b></p>  <p>(2x per sec.)</p>	  	<p>OFF</p> <p>OFF</p> <p>OFF</p>	<p>Defect engine coolant sensor or bad connection</p>	<p>After cooling down, check engine coolant level Contact authorized workshop</p>
<p>80 ° - 90 °C</p> <p><b>OFF</b></p> 	  	<p>OFF</p> <p>OFF</p> <p>OFF</p>	<p>Unstable idle speed, no indication on tachometer</p> 	<p>Defect speed sensor or sensor connection contact authorized workshop</p>
<p>80 ° - 90 °C</p> <p><b>ON</b></p> 	  	<p><b>ON</b></p> <p>OFF</p> <p>OFF</p>	<p>Trouble in governing loop, involved components: control solenoid, rack, control gear of unit injector, rack position sensor</p>	<p>Contact authorized workshop</p>

## 2.9 Service-code lists

### 2.9.1 V30000.2H (valid for engines from year of manufacture 2021)

#### **NOTICE**

Some codes may not apply due to different application!

<b>Fault Codes SE-Marine V30000.2H (17.05.2024)</b>				
<b>Dec.</b>	<b>Hex.</b>	<b>ABBREV.</b>	<b>INVOLVED DEVICE</b>	<b>POSSIBLE CAUSE</b>
71	47	VTGHBRIDGE_E-MIN	Turbocharger output control	Signal voltage too low, possible short circuit to ground
72	48	VTGHBRIDGE_E-MAX	Turbocharger output control	Signal voltage too high, possible short circuit to battery
263	107	MAP_E-MIN	Manifold Air Pressure Sensor (Boost pressure Sensor)	Signal voltage too low, possible short circuit to ground
264	108	MAP_E-MAX	Manifold Air Pressure Sensor (Boost pressure Sensor)	Signal voltage too high, possible short circuit to battery
274	112	ACT_E-MIN	Air Charge Temperature Sensor	Signal voltage too low, possible short circuit to ground
275	113	ACT_E-MAX	Air Charge Temperature Sensor	Signal voltage too high, possible short circuit to battery
279	117	ECT_E-MIN	Engine Coolant Temperature Sensor	Signal voltage too low, possible short circuit to ground
280	118	ECT_E-MAX	Engine Coolant Temperature Sensor	Signal voltage too high, possible short circuit to battery
288	120	PED_E-NPL	Accelerator Pedal	Possibly wrong pedal used
290	122	PED1_E-MIN	Potentiometer accelerator 1	Signal voltage too low, possible short circuit to ground
291	123	PED1_E-MAX	Potentiometer accelerator 1	Signal voltage too high, possible short circuit to battery
374	176	FUEL_DENSITY_E-NPL	Fuel density sensor	Measured fuel density is not in valid range/ No valid density value
375	177	FUEL_DENSITY_E-FER	Fuel density sensor	Timeout of fuel density sensor - check connection and sensor
377	179	FUEL_DENSITY_E-SIG	Fuel density sensor - signal not plausible (oszillating)	Signal not plausible (oszillating)
386	182	FT_E-MIN	Fuel Temperature Sensor	Signal voltage too low, possible short circuit to ground

Fault Codes SE-Marine V30000.2H (17.05.2024)				
Dec.	Hex.	ABBREV.	INVOLVED DEVICE	POSSIBLE CAUSE
387	183	FT_E-MAX	Fuel Temperature Sensor	Signal voltage too high, possible short circuit to battery
389	185	FT_ET1_E-NPL	Fuel Temperature Sensor via CAN message ET1	Non plausible value from FTS sensor
390	186	FT_ET1_E-FER	Fuel Temperature Sensor via CAN message ET1	CAN timeout, connection to the FTS sensor lost; check supply voltage and wiring
395	18B	PF20_RANGE_E-FER	PF20 - Fuel Pressure Sensor	Fuel pressure is below the limit
396	18C	PF20_E-MIN	PF20 - Fuel Pressure Sensor	Signal voltage too low, possible short circuit to ground
397	18D	PF20_E-MAX	PF20 - Fuel Pressure Sensor	Signal voltage too high, possible short circuit to battery
544	220	REM_PAD_E-SIG	Remote Accelerator Pedal	Time out of CAN message received from remote accelerator pedal
545	221	REM_PAD_E-NPL	Remote Accelerator Pedal	Input signal out of valid range
546	222	PED2_E-MIN	Potentiometer accelerator 2	Signal voltage too low, possible short circuit to ground
547	223	PED2_E-MAX	Potentiometer accelerator 2	Signal voltage too high, possible short circuit to battery
594	252	FMS_MALF_E-SIG	Fuel Metering Solenoid	FMS malfunction error detected
595	253	FMS_E-MIN	Fuel Metering Solenoid	0mm rack calibration position is out of bounds (SR0POS)
596	254	FMS_E-MAX	Fuel Metering Solenoid	18mm rack calibration position is out of bounds (SR18POS)
597	255	FMS_E-FER	Fuel Metering Solenoid	Non plausible fms SR0POS
599	257	RPOS_MON_E-NPL	Fuel Rack Position Sensor	RPOS signal not plausible
600	258	RPOS_E-MIN	Fuel Rack Position Sensor	Signal voltage too low, possible short circuit to ground
601	259	RPOS_E-MAX	Fuel Rack Position Sensor	Signal voltage too high, possible short circuit to battery
1029	405	EXT_E-MIN	Exhaust Temperature Sensor	Signal voltage too low, possible short circuit to ground
1030	406	EXT_E-MAX	Exhaust Temperature Sensor	Signal voltage too high, possible short circuit to battery
1314	522	LPS_E-MIN	Lubricant Pressure Sensor	Signal voltage too low, possible short circuit to ground

<b>Fault Codes SE-Marine V30000.2H (17.05.2024)</b>				
<b>Dec.</b>	<b>Hex.</b>	<b>ABBREV.</b>	<b>INVOLVED DEVICE</b>	<b>POSSIBLE CAUSE</b>
1315	523	LPS_E-MAX	Lubricant Pressure Sensor	Signal voltage too high, possible short circuit to battery
1349	545	T30_E-MIN	T30- Exhaust Temperature Sensor	Signal voltage too low, possible short circuit to ground
1350	546	T30_E-MAX	T30- Exhaust Temperature Sensor	Signal voltage too high, possible short circuit to battery
1378	562	VBATTIN_E-MIN	Battery Voltage Detection Sensor	Battery voltage too low
1379	563	VBATTIN_E-MAX	Battery Voltage Detection Sensor	Battery voltage too high
1540	604	RAMECC_E-FER	ECU	Error on ecu RAM, replace ECU with new one
1581	62D	FMS_MALF_E-FER	Fuel Metering Solenoid	Rack is not calibrated yet
1602	642	VREF1_E-MIN	VREF1 Sensor	Signal voltage too low, possible short circuit to ground
1603	643	VREF1_E-MAX	VREF1 Sensor	Signal voltage too high, possible short circuit to battery
1618	652	VREF2_E-MIN	VREF2 Sensor	Signal voltage too low, possible short circuit to ground
1619	653	VREF2_E-MAX	VREF2 Sensor	Signal voltage too high, possible short circuit to battery
1688	698	VREF3_E-MIN	VREF3 Sensor	Signal voltage too low, possible short circuit to ground
1689	699	VREF3_E-MAX	VREF3 Sensor	Signal voltage too high, possible short circuit to battery
1829	725	RPM_PRECRANK_E-FER	RPM Sensor	RPM Sensor defect, signal voltage not correct, wiring not ok
1832	728	RPM_E-SIG	RPM Sensor	RPM Sensor defect, signal voltage not correct, wiring not ok
4097	1001	ITP_E-MIN	Injection Timing Device Position Sensor	Signal voltage too low, possible short circuit to ground
4098	1002	ITP_E-MAX	Injection Timing Device Position Sensor	Signal voltage too high, possible short circuit to battery
4112	1010	ITD_INVCALIB_E-FER	Injection Timing Device	Invalid calibration value, recalibrate the ITD
4113	1011	ITD_FP_E-FER	Injection Timing Device	ITD is possibly not moving
4208	1070	FMS_E-NPL	Fuel Metering Solenoid	Non plausible position

Fault Codes SE-Marine V30000.2H (17.05.2024)				
Dec.	Hex.	ABBREV.	INVOLVED DEVICE	POSSIBLE CAUSE
4353	1101	T2_E-MIN	T2- Temperature Sensor	Signal voltage too low, possible short circuit to ground
4354	1102	T2_E-MAX	T2- Temperature Sensor	Signal voltage too high, possible short circuit to battery
4904	1328	TPCB_E-MIN	ECU Internal Temperature Sensor	Signal voltage too low, possible short circuit to ground
4905	1329	TPCB_E-MAX	ECU Internal Temperature Sensor	Signal voltage too high, possible short circuit to battery
5140	1414	MISUSE_WAR_E-FER		WAR switch misuse code activated
5424	1530	FMS_OVERCURRENT_E-FER	Fuel Metering Solenoid	Overcurrent on FMS - maybe short circuit
5426	1532	PF20_HIGH_E-FER	PF20 - Fuel Pressure Sensor	Fuel pressure is too high
6296	1898	FMS_OSCILLATION_E-FER	oszilation of the FMS dedected	Mechanical problems in the FMS
6656	1A00	INVALID_IO_CALIB_E-NPL		Software calibration fault
8744	2228	BARO_E-MIN	Barometric Pressure Sensor	Signal voltage too low, possible short circuit to ground
8745	2229	BARO_E-MAX	Barometric Pressure Sensor	Signal voltage too high, possible short circuit to battery
8809	2269	WIF_E-FER	Water in fuel sensor	There's too much water in the water separator. Service required
9572	2564	VTGPOSFB_E-MIN	Turbocharger Position Feedback	Signal voltage too low, possible short circuit to ground
9573	2565	VTGPOSFB_E-MAX	Turbocharger Position Feedback	Signal voltage too high, possible short circuit to battery

2.9.2 V50000.11B (valid for engines until year of manufacture 2020)

**NOTICE**

Some codes may not apply due to different application!

Fault Codes SE-Marine V50000.11B (17.05.2024)				
Dec.	Hex.	ABBREV.	INVOLVED DEVICE	POSSIBLE CAUSE
70	46	VTGHBRIDGE_E-FER	VTG H-Bridge	Functional error on ECU- H-Bridge
71	47	VTGHBRIDGE_E-MIN	Turbocharger output control	Signal voltage to low, possible short circuit to ground
72	48	VTGHBRIDGE_E-MAX	Turbocharger output control	Signal voltage to high, possible short circuit to battery
263	107	BARO_FP_E-MIN	Barometric Pressure Sensor	Signal voltage to low, possible short circuit to ground
264	108	BARO_FP_E-MAX	Barometric Pressure Sensor	Signal voltage to high, possible short circuit to battery
274	112	ACT_E-MIN	Ambient Air Temperature Sensor	Signal voltage to low, possible short circuit to ground
275	113	ACT_E-MAX	Ambient Air Temperature Sensor	Signal voltage to high, possible short circuit to battery
279	117	ECT_E-MIN	Engine Coolant Temperature Sensor	Signal voltage to low, possible short circuit to ground
280	118	ECT_E-MAX	Engine Coolant Temperature Sensor	Signal voltage too high, possible short circuit to battery
288	120	PED_E-NPL	Potentiometer accelerator 1 & 2	Possibly wrong pedal used
290	122	PED1_E-MIN	Potentiometer accelerator 1	Signal voltage to low, possible short circuit to ground
291	123	PED1_E-MAX	Potentiometer accelerator 1	Signal voltage to high, possible short circuit to battery
374	176	FUEL_DENSITY_E-NPL	Fuel density sensor	Measured fuel density is not in valid range/ No valid density value
375	177	FUEL_DENSITY_E-FER	Fuel density sensor	Timeout of fuel density sensor - check connection and sensor
395	18B	PF20_RANGE_E-FER	PF20 - Fuel Pressure Sensor	Fuel pressure is below the limit
396	18C	PF20_E-MIN	PF20 - Fuel Pressure Sensor	Signal voltage to low, possible short circuit to ground

Fault Codes SE-Marine V50000.11B (17.05.2024)				
Dec.	Hex.	ABBREV.	INVOLVED DEVICE	POSSIBLE CAUSE
397	18D	PF20_E-MAX	PF20 - Fuel Pressure Sensor	Signal voltage to high, possible short circuit to battery
544	220	REM_PAD_E-SIG	Remote Accelerator Pedal	Time out of can message received from remote accelerator pedal
545	221	REM_PAD_E-NPL	Remote Accelerator Pedal	Input signal out of valid range
546	222	PED2_E-MIN	Potentiometer accelerator 2	Signal voltage to low, possible short circuit to ground
547	223	PED2_E-MAX	Potentiometer accelerator 2	Signal voltage to high, possible short circuit to battery
594	252	FMS_MALF_E-SIG	Fuel Metering Solenoid	FMS malfunction error detected
595	253	FMS_E-MIN	Fuel Metering Solenoid	0mm rack calibration position is out of bounds (SR0POS)
596	254	FMS_E-MAX	Fuel Metering Solenoid	18mm rack calibration position is out of bounds (SR18POS)
600	258	RPOS_E-MAX	Rack Position Sensor	Signal voltage to high, possible short circuit to battery
601	259	RPOS_E-MIN	Rack Position Sensor	Signal voltage to low, possible short circuit to ground
899	383	TLE_OUTL2_GPR_E-MIN	Glow Plug RELAY	Signal voltage to low, possible short circuit to ground
900	384	TLE_OUTL2_GPR_E-MAX	Glow Plug RELAY	Signal voltage to high, possible short circuit to battery
1029	405	EXT_E-MIN	Exhaust Temperature Sensor	Signal voltage to low, possible short circuit to ground
1030	406	EXT_E-MAX	Exhaust Temperature Sensor	Signal voltage to high, possible short circuit to battery
1314	522	LPS_E-MIN	Lubricant Pressure Sensor	Signal voltage to low, possible short circuit to ground
1315	523	LPS_E-MAX	Lubricant Pressure Sensor	Signal voltage to high, possible short circuit to battery
1349	545	T30_E-MIN	T30- Exhaust Temperature Sensor	Signal voltage to low, possible short circuit to ground
1350	546	T30_E-MAX	T30- Exhaust Temperature Sensor	Signal voltage to high, possible short circuit to battery
1378	562	VBATTIN_E-MIN	Battery Voltage Detection Sensor	Battery voltage to low
1379	563	VBATTIN_E-MAX	Battery Voltage Detection Sensor	Battery voltage to high
1540	604	RAMECC_E-FER	ECU	Error on ecu RAM, replace ECU with new one

<b>Fault Codes SE-Marine V50000.11B (17.05.2024)</b>				
<b>Dec.</b>	<b>Hex.</b>	<b>ABBREV.</b>	<b>INVOLVED DEVICE</b>	<b>POSSIBLE CAUSE</b>
1576	628	TLE_RL1_ FPR_E-MIN	Fuel Pump Relay Output	Signal voltage to low, possible short circuit to ground
1577	629	TLE_RL1_ FPR_E-MAX	Fuel Pump Relay Output	Signal voltage to high, possi- ble short circuit to battery
1581	62D	FMS_E-FER	Fuel Metering Sole- noid	Rack is not calibrated yet
1592	638	FMS_E-SIG	Fuel Metering Sole- noid	Non plausible signal from fms
1602	642	VREF1_E-MIN	VREF1 Sensor	Signal voltage to low, possible short circuit to ground
1603	643	VREF1_E-MAX	VREF1 Sensor	Signal voltage to high, possi- ble short circuit to battery
1618	652	VREF2_E-MIN	VREF2 Sensor	Signal voltage to low, possible short circuit to ground
1619	653	VREF2_E-MAX	VREF2 Sensor	Signal voltage to high, possi- ble short circuit to battery
1688	698	VREF3_E-MIN	VREF3 Sensor	Signal voltage to low, possible short circuit to ground
1689	699	VREF3_E-MAX	VREF3 Sensor	Signal voltage to high, possi- ble short circuit to battery
1796	704	HYB_ CLUTCH_E-FER	Hybrid Transmission Clutch	Clutch is not engaged right
1829	725	RPM_ PRECRANK_E- FER	RPM Sensor	RPM Sensor defect, signal voltage not correct, wiring not ok
1831	727	RPM_SIG_E- SIG	RPM Sensor	RPM Sensor defect, signal voltage not correct, wiring not ok
2586	A1A	HCU_ ERROR_E-FER	Hybrid Control Unit	Functional error on HCU
2673	A71	HCU_ OVERLOAD_E- FER	Hybrid Control Unit	To high voltage on HCU
2684	A7C	HCU_ OVERTEMP_E- FER	Hybrid Control Unit	Overtemperature on HCU
4097	1001	ITP_E-MIN	Injection Timing De- vice Position Sensor	Signal voltage to low, possible short circuit to ground
4098	1002	ITP_E-MAX	Injection Timing De- vice Position Sensor	Signal voltage to high, possi- ble short circuit to battery
4112	1010	ITD_ INVCALIB_E- FER	Injection Timing De- vice	Invalid calibration value, re- calibrate the ITD

Fault Codes SE-Marine V50000.11B (17.05.2024)				
Dec.	Hex.	ABBREV.	INVOLVED DEVICE	POSSIBLE CAUSE
4113	1011	ITD_FP_E-FER	Injection Timing Device	ITD is possibly not moving
4148	1034	VPROT_E-MIN	Vprot Sensor	Signal voltage to low, possible short circuit to ground
4149	1035	VPROT_E-MAX	Vprot Sensor	Signal voltage to high, possible short circuit to battery
4181	1055	T30FB_E-MIN	T30 feedback	Feedback current error
4182	1056	T30FB_E-MAX	T30- Exhaust Temperature Sensor	Invalid signal level
4208	1070	FMS_E-NPL	Fuel Metering Solenoid	Non plausible position
4226	1082	HYB_ESR_TO_E-SIG	Hybrid Control Unit	Lost communication, timeout of ESR message
8191	1FFF	FAULPATH-FER	ECU FAULTS	Unexpected error detected, call software department
8744	2228	MAP_E-MIN	Manifold Air Pressure Sensor (Boost pressure Sensor)	Signal voltage to low, possible short circuit to ground
8745	2229	MAP_E-MAX	Manifold Air Pressure Sensor (Boost pressure Sensor)	Signal voltage to high, possible short circuit to battery
8805	2265	WIF_E-FER	Water in fuel sensor	There's too much water in the water separator. Service required
9572	2564	VTGPOSFB_E-MIN	Turbocharger Position Feedback	Signal voltage to low, possible short circuit to ground
9573	2565	VTGPOSFB_E-MAX	Turbocharger Position Feedback	Signal voltage to high, possible short circuit to battery
12387	3063	PF20_RANGE_E-MAX	PF20 - Fuel Pressure Sensor	Fuel pressure is above the limit
49811	C293	HCU_OFFLINE_E-FER	Hybrid Control Unit	HCU is offline, or connection is broken

### **2.10 Wiring diagram SE E-Box 12 V, 6 cyl. (standard)**

valid for engines from year of manufacture 2021

See 707610 for complete wiring schematics.

### **2.11 Wiring diagram SE E-Box 24 V, 6 cyl. (optional)**

valid for engines from year of manufacture 2021

See 707611 for complete wiring schematics.

### **2.12 Wiring diagram SE E-Box external 6 cyl. (optional)**

valid for engines from year of manufacture 2021

See 707609 for complete wiring schematics.

### **2.13 Wiring diagram SE E-Box 6 cyl. options**

valid for engines from year of manufacture 2021

See 707609 for complete wiring schematics.

### **2.14 Wiring diagram SE E-Box 12 V, 6 cyl. (standard)**

valid for engines until year of manufacture 2020

See 2181349-0 for complete wiring schematics.

### **2.15 Wiring diagram SE E-Box 24 V, 6 cyl. (optional)**

valid for engines until year of manufacture 2020

See 2181350-0 for complete wiring schematics

### **2.16 Wiring diagram SE E-Box external, 6 cyl. (optional)**

valid for engines until year of manufacture 2020

See 2181351-0 for complete wiring schematics.

### **2.17 Wiring diagram SE E-Box 6 cyl. options**

valid for engines until year of manufacture 2020

See 2181349-0 for complete wiring schematics.

## 2.18 Wiring harness SE 6 cyl.

Designation	Component	Description
A1		M1CU3
B1	plug 3-pole	RPOS Rack position
B2		ITP Injection timing device position
B3	plug 3-pole	RPM Engine speed
B4	plug 3-pole	MAP Manifold absolute pressure
B5	plug 3-pole	LPS Lubricant pressure
B6	plug 2-pole	ECT Engine coolant temperature
B7		ACT Air charge temperature
B8	plug 2-pole	EXT Engine exhaust temperature
B9	plug 5-pole	CMD Pedal
B10		FSP Fuel supply pressure
B12		FT Fuel temperature sensor (as of 2021)
F1	Fuse 20 A	VBATT
F2	Fuse 25 A	Fuel supply pump
F3	Fuse 20 A	ECU Electronic control unit
F4	Fuse 50 A	Glow plugs
F5	Fuse 50 A	Glow plugs
F6	Fuse 10 A	Alternator
G1		Lima
K1		MR Main relay
K2		FPR Fuel supply pump relay
K3		GPR Glow plug relay
K4		SER Start enable relay
M1		Starter motor
X1		Panel
X2		Diag.
X3		Harness intake side
X4		WIF Water in fuel
X5		GND
X6		Fuel supply pump
X9		Option 24 V
X20		Hybrid
X21		Option MET/FDS
X22		Option Trim/Gear
X23		SOLAS inversion switch
X25		Option VTG/SCI
X26		Option GIR 2-pol
Y1		FMS Fuel metering solenoid
Y2		ITV Injection timing valve

### **2.19 Wiring diagram SE E-Box 12 V, 4 cyl. (standard)**

valid for engines from year of manufacture 2021

See 707711 for complete wiring schematics.

### **2.20 Wiring diagram SE E-Box 12 V, 4 cyl. options**

valid for engines from year of manufacture 2021

See 707711 for complete wiring schematics.

### **2.21 Wiring diagram SE E-Box 12 V, 4 cyl. (standard)**

valid for engines until year of manufacture 2020

See 701668 for complete wiring schematics.

### **2.22 Wiring diagram SE E-Box 12 V, 4 cyl. options**

valid for engines until year of manufacture 2020

See 701668 for complete wiring schematics.

## 2.23 Wiring harness SE 4 cyl.

Designation	Component	Description
A1		M1CU3
B1	plug 3-pole	RPOS Rack position
B2		ITP Injection timing device position
B3	plug 3-pole	RPM Engine speed
B4	plug 3-pole	MAP Manifold absolute pressure
B5	plug 3-pole	LPS Lubricant pressure
B6	plug 2-pole	ECT Engine coolant temperature
B8	plug 2-pole	EXT Engine exhaust temperature
B9	plug 5-pole	CMD Pedal
B10		FSP Fuel supply pressure
B12		FT Fuel temperature sensor (as of 2021)
F1	Fuse 20 A	VBATT
F2	Fuse 25 A	Fuel supply pump
F3	Fuse 20 A	ECU Electronic control unit
F4	Fuse 50 A	Glow plugs
F5	Fuse 50 A	Glow plugs
F6	Fuse 10 A	Alternator
G1		Lima
K1		MR Main relay
K2		FPR Fuel supply pump relay
K3		GPR Glow plug relay
K4		SER Start enable relay
M1		Starter motor
X1		Panel
X2		Diag.
X4		WIF Water in fuel
X5		GND
X6		Fuel supply pump
X9		Option 24 V
X20		Hybrid
X21		Option MET/FDS
X22		Option Trim/Gear
X23		SOLAS inversion switch
X25		Option VTG/SCI
X26		Option GIR 2-pol
Y1		FMS Fuel metering solenoid
Y2		ITV Injection timing valve

**2.24 Wiring diagram Instrument CAN Panel 12/24 V**

See 2181471-0 for complete wiring schematics.

**2.25 Wiring diagram Instrument CAN Panel Solas 12/24 V**

See 2181470-0 for complete wiring schematics.

### 3 Maintenance activities

#### 3.1 Check engine oil level

##### **CAUTION**

Check with cool engine only, or after a shut down period of approx. 3 to 5 min.

Remove oil dipstick (A), clean it and insert it into oil dipstick tube, then remove oil dipstick (A) again and check oil level on marker.

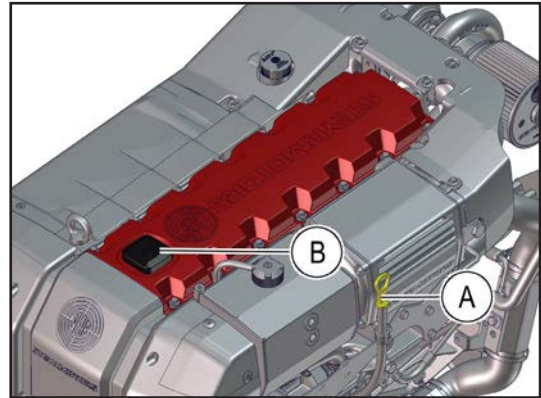

Fig. 56

#### 3.2 Refill engine oil

1. Remove engine oil filler cap (B) and add Steyr Motors high performance diesel engine oil up to specified maximum marker on oil dipstick.

##### **CAUTION**

Engine oil must not exceed maximum marker. Overfilling results in high operating temperatures, foaming (air in oil), loss in efficiency and reduced engine life.

2. Put on the engine oil filler cap.

##### **NOTICE**

Remove possible oil contaminations.  
To use engine oil of other quality than specified, warranty expires.

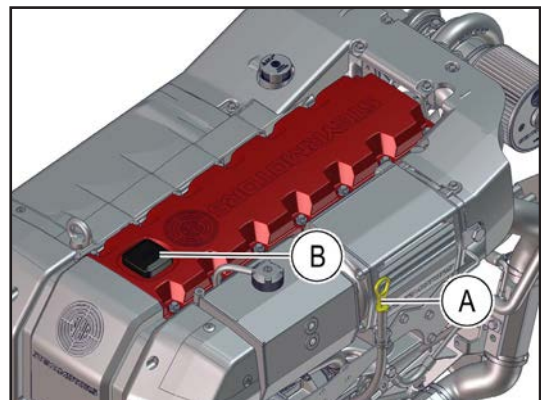

Fig. 57

### 3.3 Oil level for power steering

1. Whenever you check engine oil level, also check oil level of power steering. If required, add automatic transmission oil (available at your **Steyr Motors** marine dealer). Other approved oils, such as GM Servo or Dexron II, may also be used. Do not overfill pump reservoir.

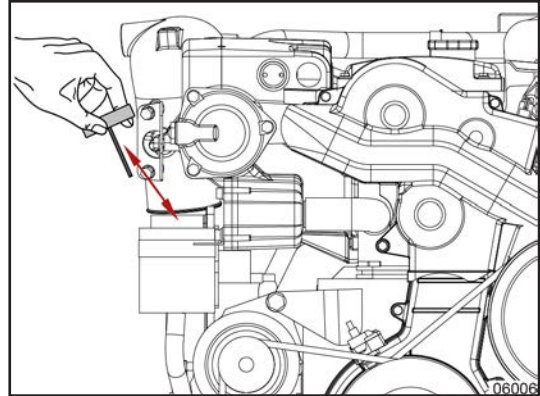

Fig. 58

### 3.4 Oil level for transmission

1. Whenever you check engine oil level, also check oil level of transmission. If required, add automatic transmission oil (available at your **Steyr Motors** marine dealer). Other approved oils, such as GM Servo or Dexron II, may also be used. Do not overfill transmission.

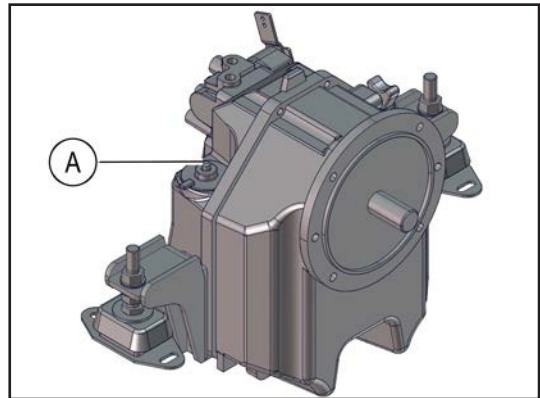

Fig. 59

---

#### **NOTICE**

Consider specifications of respective transmission manufacturer.

---

### 3.5 Check coolant (Closed cooling circuit)

#### **CAUTION**

With hot engine, the closed cooling circuit is under pressure. Do not try to open the radiator cap or the drain plugs when engine is hot. This may cause severe injuries by hot coolant. As soon as the engine has cooled down, the cap may be opened.

1. Open the radiator (1) cap slowly and release the pressure in the system.

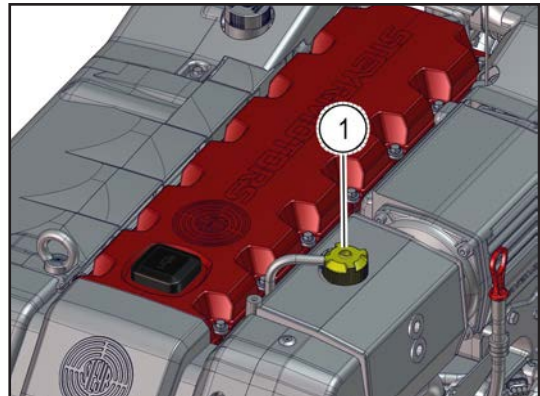

Fig. 60

#### **CAUTION**

Only add **Steyr Motors** engine coolant.

2. Coolant level should reach the "MAX" marking (A) in the expansion tank. Refill coolant only at the expansion tank.

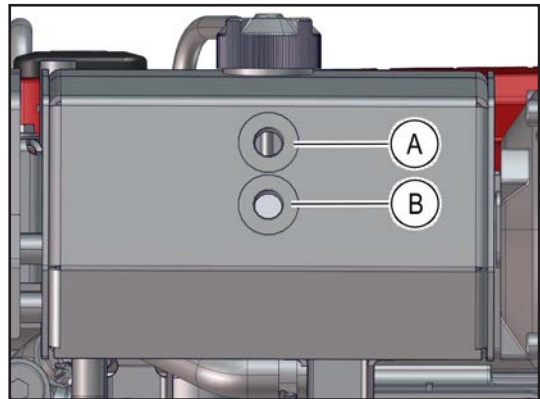

Fig. 61

#### **NOTICE**

When not using original **Steyr Motors** coolant, severe damage to the cooling system of your engine may occur.

#### **Drain points of coolant circuit:**

- 1) Engine block
- 2) Oil cooler
- 3) Heat exchanger housing

#### **Check Coolant SE-Series:**

#### **CAUTION**

Only open the radiator cap when the engine is cold!

Open the radiator cap slowly and release the pressure in the system!

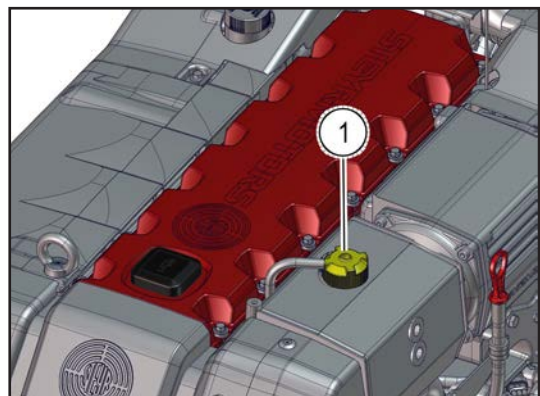

Fig. 62

### 3.6 Drain the raw water circuit of the engine

#### CAUTION

Not draining the raw water circuit in time before the winter season and/or daily when running the engine during the winter season, may lead to freeze damage to the engine.

1. Remove drain plug **(A)**. Engine empties itself via exhaust system.

#### NOTICE

Drain plug **(A)** is not available for all types, in that case remove the hose.

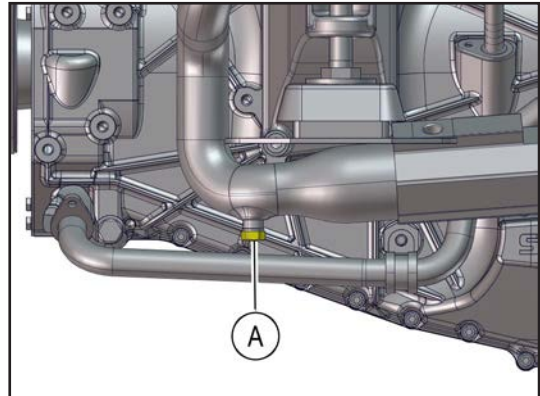

Fig. 63 6 cylinder

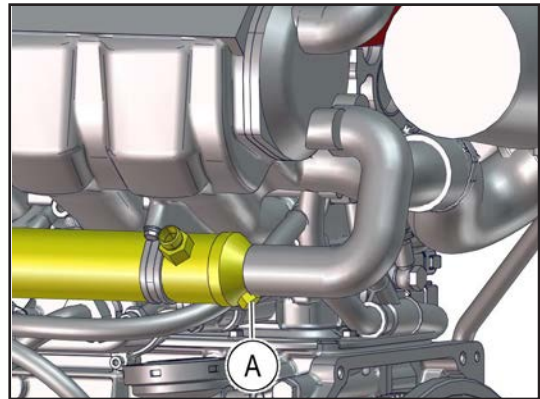

Fig. 64 4 cylinder

2. Loosen 2 hose clamps **(A)** and remove raw water hoses. Quickly start the engine so that raw water pump empties itself.  
**(B)** = Raw water inlet

#### NOTICE

As to the procedure for draining the remaining equipment on your boat, see your **Steyr Motors** marine dealer.

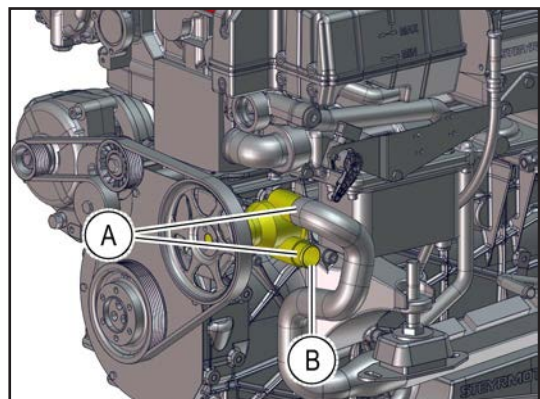

Fig. 65

### 3.7 Check raw water connection

Filling is done automatically via raw water pump after having started the engine.

### 3.8 Drain the cooling water circuit of the engine

#### CAUTION

Not draining the cooling water circuit before the winter season and daily when running the engine during the winter season, may lead to freeze damage on the engine.

1. Remove drain plug **(A)**.
2. Quickly start the engine so that cooling water pump empties itself.

To fill or refill see chapter check coolant.

#### **NOTICE**

As to procedure for draining the remaining equipment on your boat, see your **Steyr Motors** marine dealer.

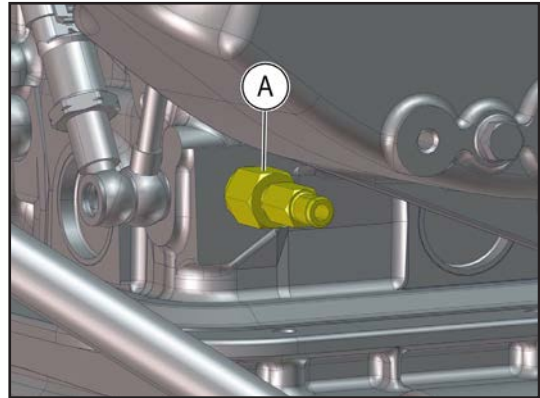

Fig. 66 6 cylinder

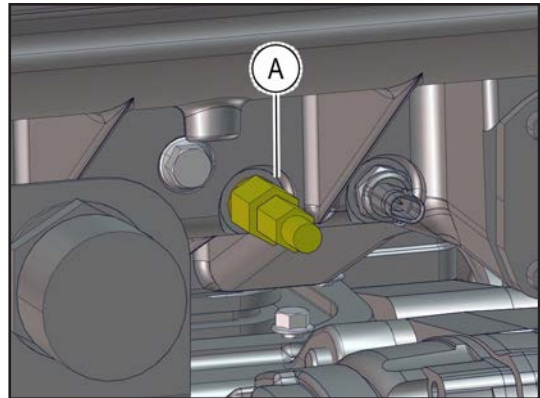

Fig. 67 4 cylinder exhaust side

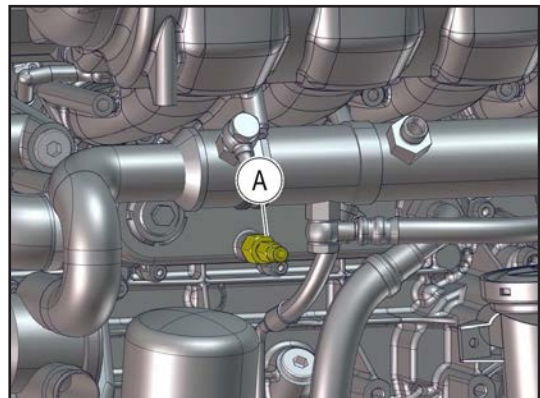

Fig. 68 4 cylinder suction side

### 3.9 Anodes 6 cylinder engine

#### 3.9.1 Cooling system anodes

Normally there are two sacrificial zinc anodes in the raw water cooling system.

If an exhaust high riser is used, there is one extra installed (see following figures).

Remove and inspect anodes for galvanic erosion according to the maintenance schedule.

Replace anode when material loss is 50 - 75 %.

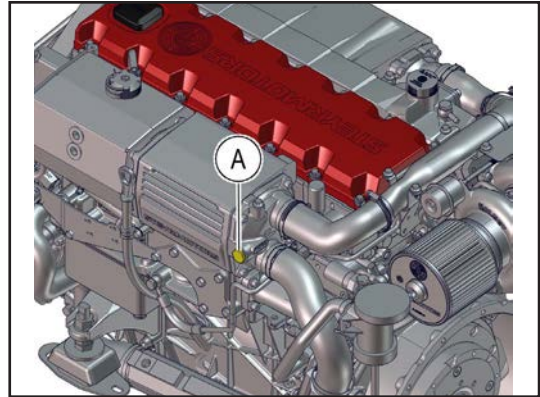

Fig. 69

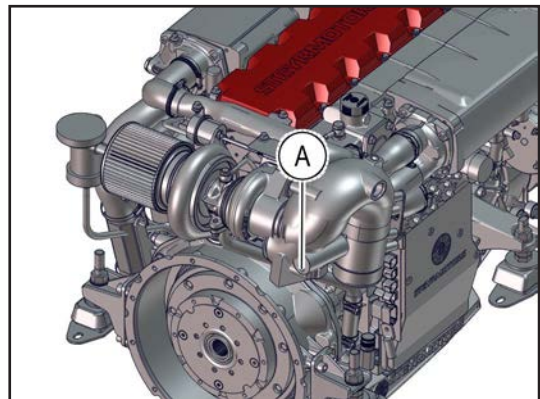

Fig. 70

#### 3.9.2 Anti-corrosion anodes

If additional electronic equipment is installed, each should have an individual anode or grounding device and all grounding devices must be interconnected. Follow recommendations of manufacturers of equipment.

---

#### **NOTICE**

Inspect anodes every 30 days, or more frequently if used in extremely salty water. Anode is to be replaced according to the maintenance schedule.

---

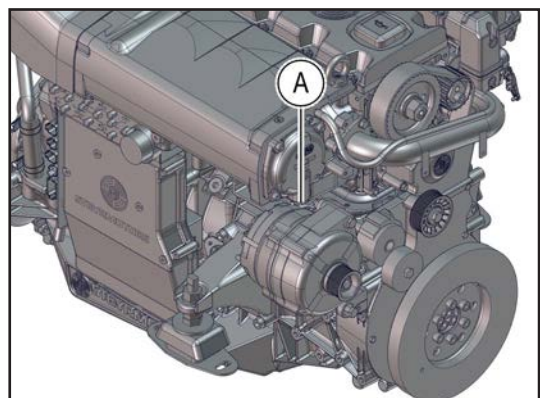

Fig. 71

Boats that connect to an AC power source (shore power) require protection against increased potential of galvanic and “spray current” corrosion. For protection, a galvanic isolator can be installed in series with the grounding (green) wire in the shore power cable between the boat and the shore power outlet on the dock. The isolator blocks direct current (DC) flow, but permits the passage of alternating current (AC) thus providing a path for ground fault currents.

---

### ***NOTICE***

If a boat is connected to an AC power source (shore power), and it is not equipped with a galvanic isolator, the zinc anti-corrosion anodes may be unable to handle the added corrosion potential.

---

### 3.10 Anodes 4 cylinder engine

#### 3.10.1 Cooling system anodes

Normally there are four sacrificial zinc anodes in the raw water cooling system. If an exhaust high riser is used, there is one extra installed see following figures.

Remove and inspect anodes for galvanic erosion according to the maintenance schedule.

Replace anode when material loss is 50 - 75 %.

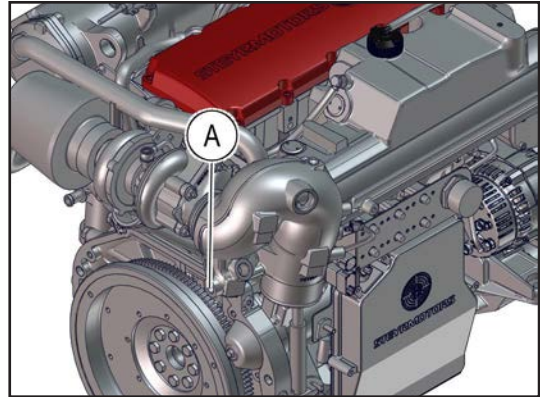

Fig. 72

#### 3.10.2 Anti-corrosion anodes

If additional electronic equipment is installed, each should have an individual anode or grounding device and all grounding devices must be interconnected. Follow recommendations of equipment manufacturers.

---

#### **NOTICE**

Inspect anodes every 30 days, or more frequently if used in extremely salty water. Anode is to be replaced according to the maintenance schedule.

---

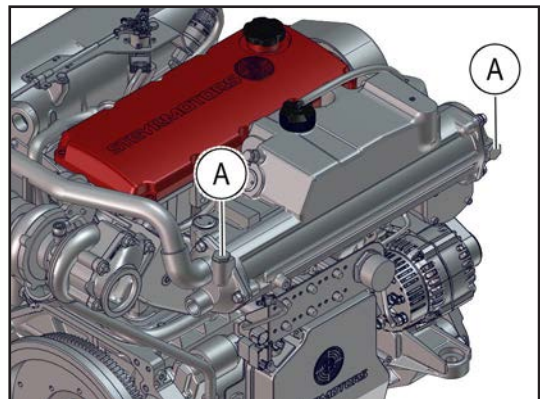

Fig. 73

Boats that connect to an AC power source (shore power) require protection against increased potential of galvanic and “spray current” corrosion. For protection, a galvanic isolator can be installed in series with the grounding (green) wire in the shore power cable between the boat and the shore power outlet on the dock. The isolator blocks direct current (DC) flow, but permits the passage of alternating current (AC) thus providing a path for ground fault currents.

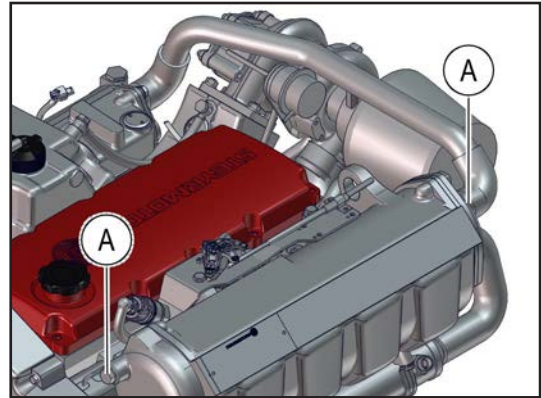

Fig. 74

### **NOTICE**

If a boat is connected to an AC power source (shore power), and it is not equipped with a galvanic isolator, the zinc anti-corrosion anodes may be unable to handle the added corrosion potential.

### 3.11 Air filter

All **Steyr Motors** marine engine models are equipped with an air filter at the turbocharger inlet; as to specifications, see specifications and maintenance.

1. Loosen clamp **(1)** to exchange air filter.
2. Remove air filter.
3. Place clamp **(1)** on filter neck and mount air filter onto flange. Tighten clamp **(3 Nm)**.

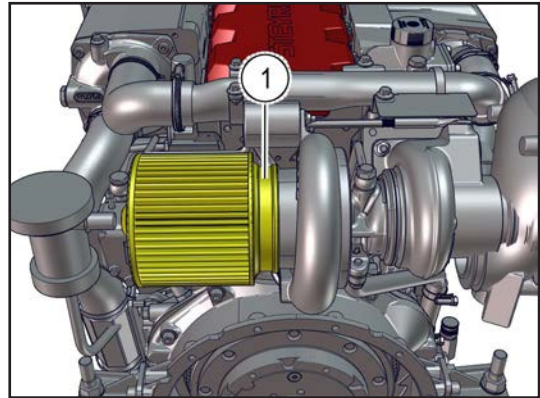

Fig. 75

### 3.12 Maintenance poly-v belt 6 cylinder engine

Occasionally check components for excessive wear and/or clearance on tension bearing.

---

#### **NOTICE**

It is recommended to frequently spray some corrosion inhibiting spray into the spring housing of the belt tensioner.

---

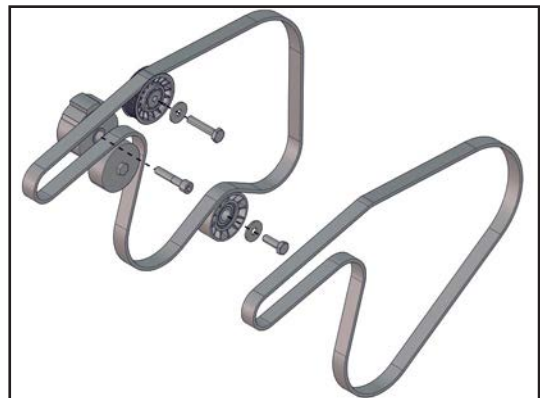

Fig. 76

### 3.13 Maintenance poly-v belt 4 cylinder engine

Occasionally check components for excessive wear and/or clearance on tension bearing.

---

#### **NOTICE**

It is recommended to spray frequently some corrosion inhibiting spray into the spring housing of the belt tensioner.

---



Fig. 77

### 3.14 Engine alignment

Engine alignment requires special tools. The output coupler must be disengaged from the take-off shaft. This should be rechecked during off-season storage preparations. Because of the special tools required, engine alignment is to be performed by a **Steyr Motors** marine dealer.

#### **NOTICE**

Failure to check the engine alignment could result in premature failure of engine coupler or universal joints.

#### 3.14.1 Engine alignment with AC-compressor

To tension the poly-v belt:

1. Loosen hexagon screw **(F)**.
2. Turn the clamping bolt **(G)** clockwise in order to increase the belt tension to **200 ± 25 Nm**.
3. Tighten hexagon screw **(F)** with a Torque of **23 ± 2 Nm** to secure idle pulley bracket.
4. Check belt tension.

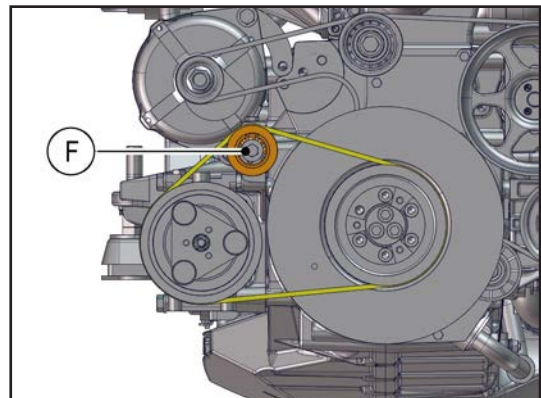

Fig. 78

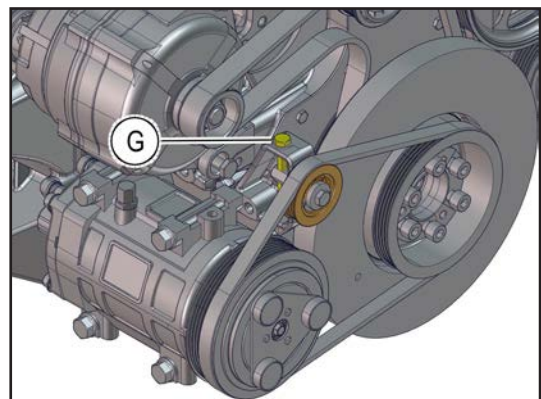

Fig. 79

### 3.15 Propeller selection

Your **Steyr Motors** marine dealer has chosen a propeller designed to deliver top performance and economy under most conditions. To obtain the maximum percentage of available power output (A), the engine RPM at **full throttle** should be in the specified **propped speed range** (←B→). As to specifications, see Technical Data and Maintenance.

If the engine's full throttle RPM with normal load is below the specified range, use a propeller with less pitch to increase the RPM. Should the engine's full throttle RPM exceed the specified range, the engine RPM and output is limited by the governor. Use a propeller of higher pitch to achieve a RPM reduction in the specified range (←B→).

#### NOTICE

Engine damage can result from incorrect propeller selection if:

- The engine RPM **does not attain** the specified "**Propped speed range**".  
The engine thus runs in RPM range (←C→).  
Therefore, use a propeller with a **lower pitch**.
- The engine RPM **exceeds** the specified "**Propped speed range**".  
Engine speed is therefore above the admissible range (←D→).  
Therefore, use a propeller with a **higher pitch**.

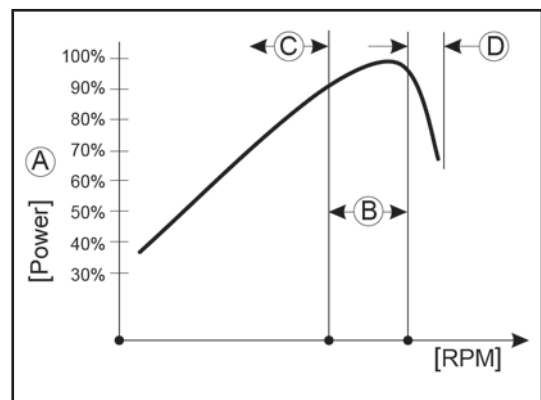

Fig. 80

Engine model		Propped speed range "B"		
		Rated speed [rpm]	Selection range [rpm]	
			Standard propeller / Stern drive	Jet drive
6 cylinder	SE126E32	3200	2800 - 3250	2550 - 3250
	SE156E34	3400	3100 - 3450	2800 - 3450
	SE186E38	3800	3500 - 3850	3300 - 3850
	SE236E40	4000	3900 - 4100	3700 - 4100
	SE236S36	3600	3400 - 3650	3300 - 3650
	SE266E40	4000	3850 - 4050	3700 - 4050
	SE266S36	3600	3300 - 3650	3300 - 3650
	SE286E40	4000	3900 - 4150	3700 - 4150
	SE306J38	3800	n.a. (Jet only)	3600 - 3850
4 cyl.	SE144E38	3800	3700 - 3850	3300 - 3850
	SE164E40	4000	3900 - 4050	3550 - 4050

### 3.16 Preparations for off-season storage

An adequate preservation of the engine will contribute to an efficient and trouble free operation in the long term.

Consult your **Steyr Motors** marine dealer to get professional assistance in performing a proper off season storage.

---

#### **NOTICE**

If engine is stored above 1 year, advise your **Steyr Motors** marine dealer to the Extended Preservation Procedure, refer to “4.5 Extended storage preservation procedure”.

---

1. Change engine oil and oil filter.
  2. Change fuel filter.
  3. Check air filter.
  4. Check coolant (closed circuit).
  5. Drain engine's raw water system.
- 

#### **NOTICE**

If the raw water is not completely removed from the engine, expensive freeze damage may result.

---

6. Drain raw water system from boat and driving system (consider manufacturer's instructions as to storage).
7. Change gear oil or lubricant.
8. Disconnect battery and store it.
9. Spray engine outside with corrosion prevention oil.
10. Ventilate engine compartment and bilge.

### 3.16.1 Start-up after storage

Correct start-up of the engine will contribute to an efficient and trouble-free operation in the long term.

Your **Steyr Motors** marine dealer will gladly be available as a consultant or for an expert performance.

1. Check condition of hoses and hose clamps.
2. Clean battery terminals.

---

#### **CAUTION**

Connect RED cable to positive terminal and then BLACK cable to negative terminal.  
Wrong connection of battery terminals may damage the electronic system.

---

3. Grease outer sides of terminals.
4. Open fuel stop valve and check all fuel lines for leakage.
5. Thoroughly check the boat and engine for slack or missing screws or nuts.
6. Pump the bilge dry and clean the engine compartment.
7. Complete the raw water system.
8. Open the raw water inlet.

---

#### **CAUTION**

Insufficient raw water supply may damage the engine and the raw water pump.

---

9. Test run. Start engine. Check voltmeter, oil pressure and water temperature gauge.  
(Make sure that all systems function properly.)
10. Check all parts for oil, fuel or water leakage.

---

#### **NOTICE**

For additional information regarding engine preparation for long term preservation please consult your **Steyr Motors** marine service partner.

---









---

## 4 Transport and storage

---

### CAUTION

#### **Damage due to improper transport!**

Significant damage to property and injuries to persons can occur in the case of improper transport.

- ▶ Proceed carefully when unloading the packages and on delivery and internal transport and observe the signs and notices on the packing.
  - ▶ Only use the attachment points provided.
  - ▶ Do not remove packing until just before the installation.
- 

### WARNING

#### **Risk of injuries due to lifted load!**

Improper loading can cause accidents with serious injuries or death.

- ▶ There must be no persons in the danger zone. When lifting the engine make sure that nobody is on the engine or steps under the suspended load.
  - ▶ The crane must be operated by authorised personnel, only.
  - ▶ Lifting tools and slings must be approved, tested and adequately dimensioned.
  - ▶ The engine must only be lifted at the intended lifting points.
  - ▶ Let the engine swing out till the balance, condition and position of slings are satisfying and lift the engine slowly to the required height for loading.
  - ▶ Wear the appropriate personal protective equipment.
-

### 4.1 Transport inspection

Check the delivery immediately on receipt for completeness and transport damage.

If externally detectable transport damage is found, proceed as follows:

- Do not accept the delivery, or only with reservation.
- Record the extent of transport damage in the transport documents or on the delivery note of the forwarding agent.
- Start complaints procedure.

---

#### Information

Claim any damage as soon as it is detected!

Compensation claims can only be submitted within the applicable complaints periods.

---

## 4.2 Packing

---

### **NOTICE**

#### **Material damage due to incorrect transport packaging!**

Using an incorrect transport packaging can cause material damage at the engine.

- ▶ Use the original transport packaging.
- 

### 4.2.1 Concerning packing

The individual packages have been packed to match the transport conditions that can be expected. Only environmentally friendly materials were used for packing.

The packing has the function of protecting the individual components against damage, corrosion, etc., until they are finally assembled. Therefore the packing material must not be damaged and should only be removed just before assembly takes place.

---

### **NOTICE**

#### **Material damage due to incorrect transport packaging!**

Using an incorrect sea transport packaging can cause material damage at the engine.

- ▶ Use a correct sea transport packaging.
- 

### 4.2.2 Handling packing materials

If there is no returns agreement for the packing, separate materials according to type and size and direct to further use or recycling.

---

#### **Environment**

#### **Environmental damage caused by incorrect waste disposal!**

Packing materials are valuable raw materials and can continue to be used in many cases or sensibly reconditioned and recycled.

- ▶ Dispose packing materials environmentally.
  - ▶ Follow the locally valid waste disposal regulations. If necessary employ a special waste disposal company to organise the disposal of packing material.
-

### 4.3 Transport

---

#### **WARNING**

##### **Risk of injuries due to lifted load!**

Improper loading can cause accidents with serious injuries or death.

- ▶ There must be no persons in the danger zone. When lifting the engine make sure that nobody is on the engine or steps under the suspended load.
  - ▶ The crane must be operated by authorised personnel, only.
  - ▶ Lifting tools and slings must be approved, tested and adequately dimensioned.
  - ▶ The engine must only be lifted at the intended lifting points.
  - ▶ Let the engine swing out till the balance, condition and position of slings are satisfying and lift the engine slowly to the required height for loading.
  - ▶ Wear the appropriate personal protective equipment.
- 

#### **NOTICE**

Two lifting eyes are mounted on top of the engine. Use the lifting eyes only for lifting the engine to avoid damage.

Be sure that the lifting means are positioned vertically. See illustration below for correct positioning of the lifting means.

- ▶ Use a special tool for the correct vertical alignment of the lifting means.
- 

#### **6 cylinder engine**

1. Fasten appropriate lifting means (up to 500 kg) to the lifting eyes **(1)**.
2. Wait until the engine completed its swing. Lift and transport engine.

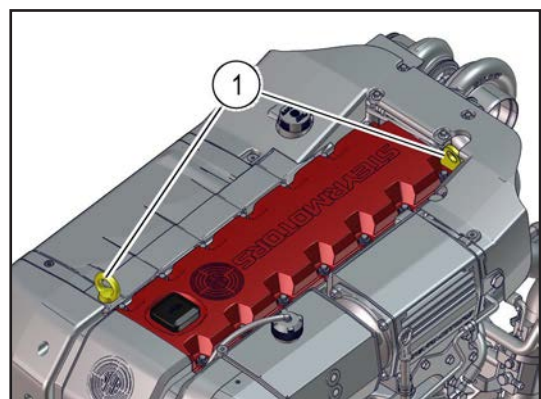

Fig. 81

### 4 cylinder engine

1. Fasten appropriate lifting means (up to 500 kg) to the lifting eyes **(1)**.
2. Wait until the engine completes its swing. Lift and transport engine.

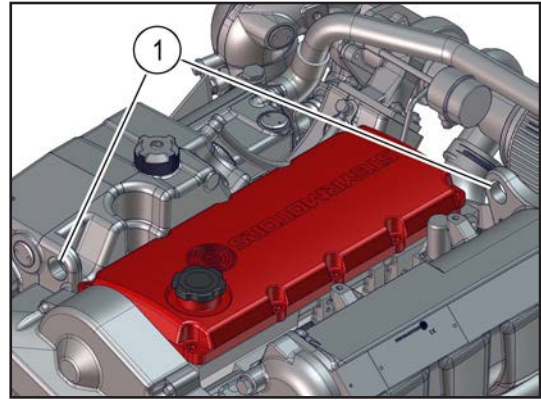

Fig. 82

Store new engines under the following conditions:

- Store in original packaging.
- Do not store outdoors.
- Store dry and dustfree.
- Do not expose to any aggressive media.
- Protect against direct sunlight.
- Avoid mechanical vibrations.
- Storage temperature: 15 to 35 °C.
- Relative humidity: max. 60 %.
- All openings (e.g. intake air, exhaust, etc.) need to be closed with protective caps.
- In the case of storage for longer than 3 months, check the general condition of all parts and the packing regularly. If required, refresh or renew the anti-corrosion protection.

Storage of the engines up to 12 months is possible under the above conditions.

### CAUTION

#### Damage due to improper storage!

Parts of the engine can corrode and become nonfunctional in the case of too high relative humidity or air containing salt.

- ▶ In the case of storage for longer than 12 months, contact the nearest **Steyr Motors** service partner in order to ensure suitable precautions.

### 4.4 Storage

---

#### **NOTICE**

##### **Damage due to improper storage.**

- ▶ Observe storage instructions.
- 

#### 4.4.1 Storage conditions

An adequate preservation of the engine will contribute to an efficient and troublefree operation in the long term.

Consult an authorized **Steyr Motors AG** service partner to get professional assistance in performing a proper off season storage.

1. Change motor oil and oil filter.
  2. Change fuel filter.
  3. Check air filter.
  4. Check coolant (closed circuit).
  5. Drain engine's raw water system.
- 

#### **NOTICE**

**Engine damage. If the raw water is not completely removed from the engine, expensive freeze damage may result.**

- ▶ Drain engine's raw water system completely.
- 

6. Drain raw water system from boat and driving system (consider manufacturer's instructions as to storage).
7. Change gear oil or lubricant as per manufacturers specification.
8. Disconnect battery and store it in a dry and frost free place.
9. Spray engine outside with corrosion prevention oil.
10. Ventilate engine compartment and bilge.

#### 4.4.2 Start-up after storage

A correct start-up of the engine will contribute to an efficient and troublefree operation in the long term.

Your **Steyr Motors AG** service partner will be glad to advise you or provide expert services.

1. Check condition of hoses and hose clamps.
2. Clean battery terminals.

---

### **NOTICE**

**Incorrect connection of battery terminals can damage the electronic system.**

- ▶ Connect RED cable to the positive terminal and then BLACK cable to the negative terminal.

- 
3. Grease outer sides of terminals.
  4. Open fuel stop valve and check all fuel lines for leakage.
  5. Thoroughly check the boat and engine for slack and missing screws or nuts.
  6. Pump the bilge dry and clean the engine compartment.
  7. Complete the raw water system.
  8. Open the raw water inlet.

---

### **NOTICE**

**Insufficient raw water supply can damage the engine and the raw water pump.**

- ▶ Ensure sufficient raw water supply.

- 
9. Perform a test run.
    - Start engine
    - Check voltmeter
    - Check oil pressure
    - Check engine coolant temperature
    - Make sure that all systems are working properly
  10. Check all parts for oil-, fuel- or water leakage.

---

### **i** Information

For additional Information regarding engine preparation for long term preservation, consult your **Steyr Motors AG** - service partner.

---

### 4.5 Extended storage preservation procedure

---

#### **NOTICE**

Valid for all 4 and 6 cylinder marine engine models!

Brand new or winter storage!

The preservation procedure must be performed by service personnel.

---

#### **Warranty** - For eligible engines

- **Steyr Motors** engines standard 12 month warranty begins on date of dispatch from the factory.
- Preserving the engine as described below delays start of warranty by 12 months from date of 1<sup>st</sup> Preservation.
- Performing the 2<sup>nd</sup> Preservation delays start of warranty by a further 12 months.
- **Steyr Motors** engines can be preserved from the factory for a maximum of 36 months from date of dispatch from factory, (initial - 12 months / 1<sup>st</sup> Preservation - 12 months / 2<sup>nd</sup> Preservation - 12 months).
- Commissioning should be performed within 30 hours / 30 days of de-preservation and notified to **Steyr Motors** within 60 days of de-preservation.
- Preservation must be notified to **Steyr Motors** within 60 days.
- Commissioning, preservation, de-preservation should be sent to:  
[commissioning@steyr-motors.com](mailto:commissioning@steyr-motors.com)

#### **Required tools:**

- Oil change tools / containers
- Coolant containers - if draining coolant
- Fuel system - supply / return hoses, fuel container
- Battery
- Battery connection cables

Consumables / parts required:

---

**NOTICE**

For the most up to date information on consumables approved by SMO please refer to our website <https://www.steyr-motors.com>.

---

- **Protection wax** (external corrosion protection)
  - quantity: 400 ml
- **Anti-corrosive oil** (internal corrosion protection)
  - quantity: 300 ml
- **Fuel additive**
  - quantity: 100 ml
  - must be specified to stabilise fuel for greater than or equal to 12 months.
- **Diesel EN 590**

4.5.1 Preservation

4.5.1.1 1<sup>st</sup> Preservation procedure

1. Remove packing from around engine.

---

**NOTICE**

**Retain packing for reuse!**

---

2. Connect instrument panel.
3. Connect electrical supply.
  
4. Remove poly-v belt.

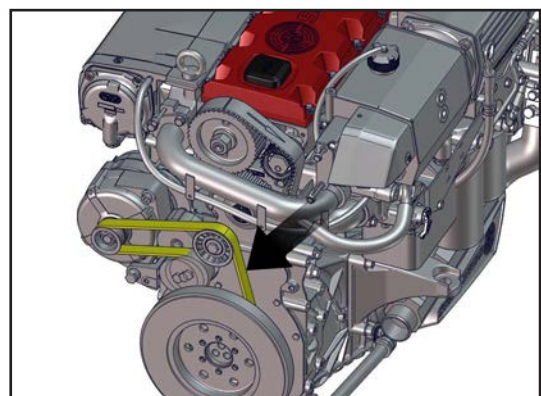

Fig. 83

## Transport and Storage

5. For storage longer than 6 months, it is recommended to remove raw water pump.
6. Remove raw water pump impeller.
7. Store raw water pump impeller in airtight package.

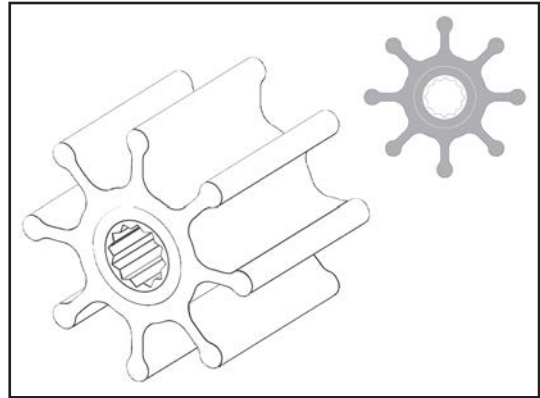

Fig. 84

### Remove camshaft housing cover

8. Unscrew 14 hexagon screws (WS 10).
9. Remove camshaft housing cover.

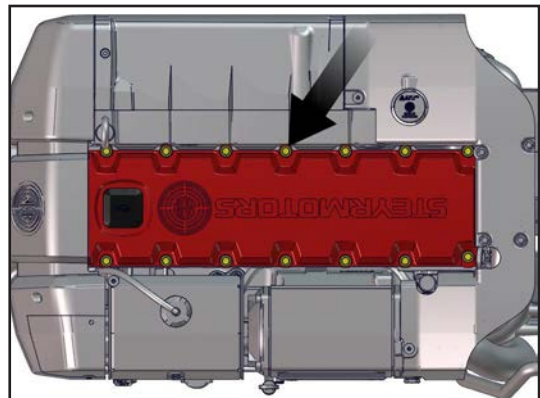

Fig. 85

10. Turn crankshaft 2 turns clockwise.

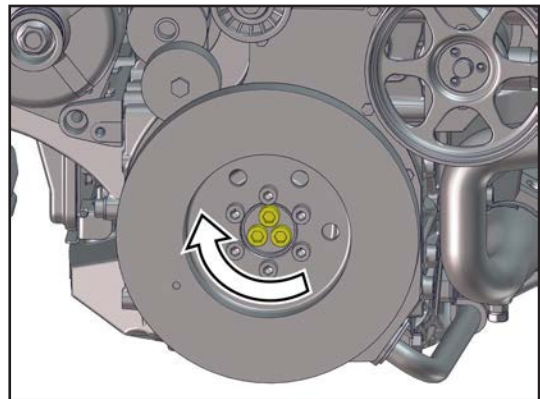

Fig. 86

11. Move control rack e. g. with a screwdriver and check for ease of movement of the control gear rods.

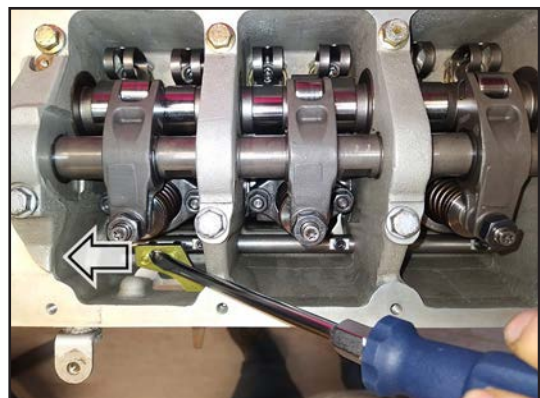

Fig. 87

**NOTICE**

Check ease of movement of the control gear rod (1) for each cylinder.

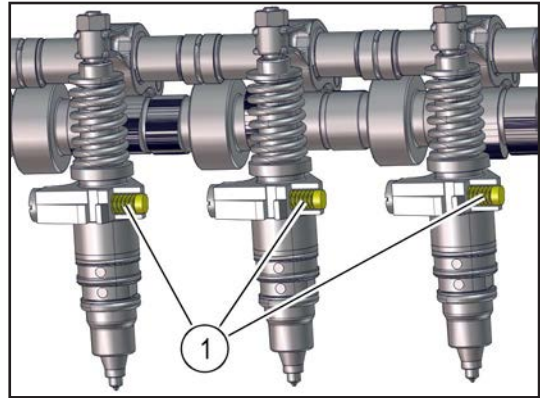

Fig. 88

Mount camshaft housing cover

12. Put camshaft housing cover onto camshaft housing.

13. Tighten with 14 hexagon screws (WS 10) with a torque of  $9.5 \pm 0.5 \text{ Nm}$ .

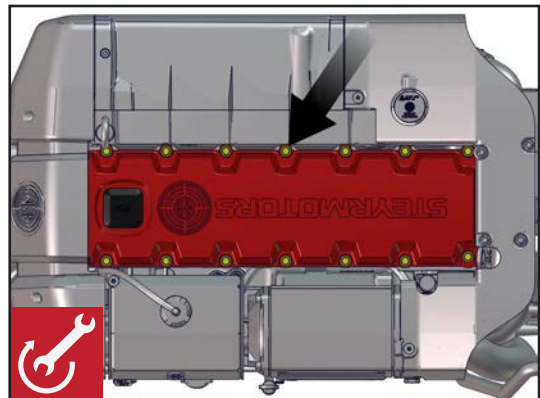

Fig. 89

14. Add 300 ml anti-corrosive oil to engine oil.

**NOTICE**

Oil level may not exceed MAX!

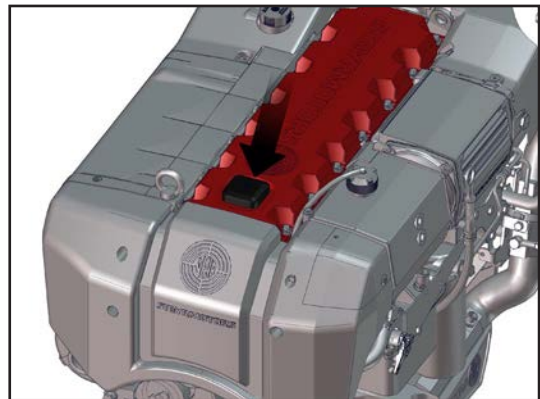

Fig. 90

15. Mix fuel stabiliser with fresh diesel in separate small fuel canister to specified ratio.

**Ratio:** 100 ml fuel stabiliser : 5 litres EN 590 Diesel

16. Connect fuel return line (ID = 8 mm) (2) ...

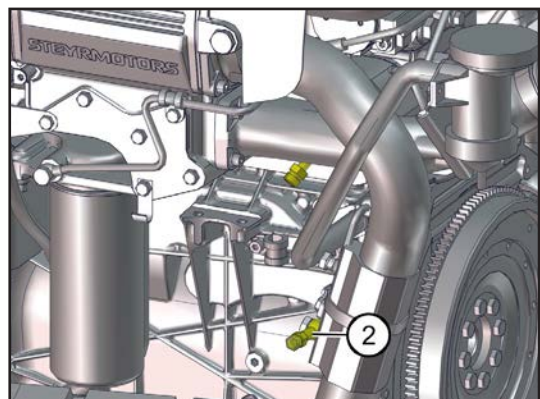

Fig. 91

## Transport and Storage

---

17. ... and fuel supply line (ID = 16 mm) **(1)** ...

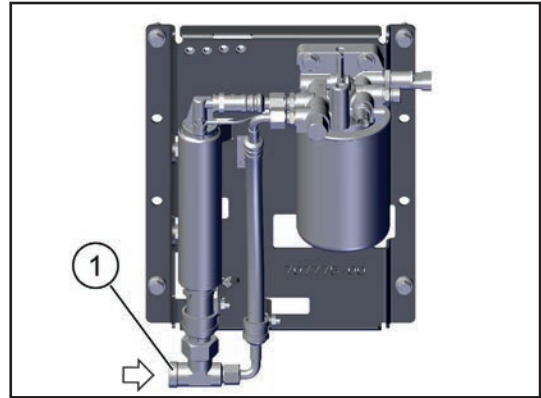

Fig. 92

18. ... to separate small fuel canister **(3)**.

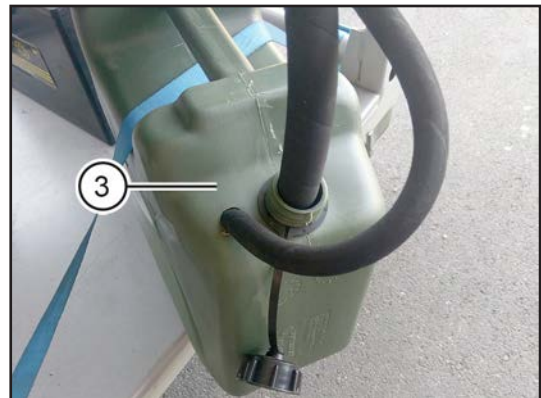

Fig. 93

19. Run engine at idle or maximum 1500 rpm (without load) until an operating temperature of 60 °C is reached.

---

### **NOTICE**

Let engine cool down to 40° C before the next steps.

---

20. Remove fuel return line and fuel supply line.

21. Remove air filter.

22. Store air filter in airtight package.

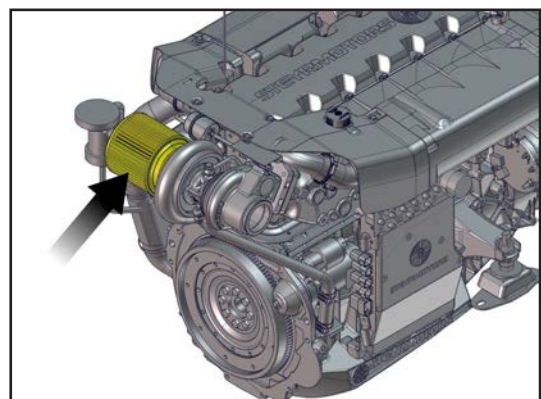

Fig. 94

23. Spray anti-corrosive oil into air intake and exhaust side to preserve the turbo charger.

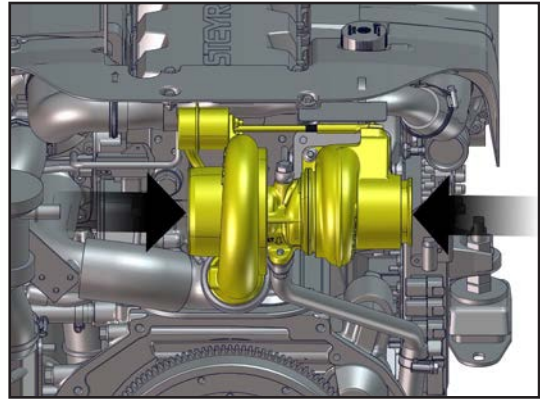

Fig. 95

24. Close (seal) all openings [oil separator (as shown), intake, exhaust, fuel lines, turbo charger] with protection caps.
25. Coat unpainted parts of engine assembly with protection wax.
26. Repack engine in original packing.
27. Store engine according to "4.4.1 Storage conditions".

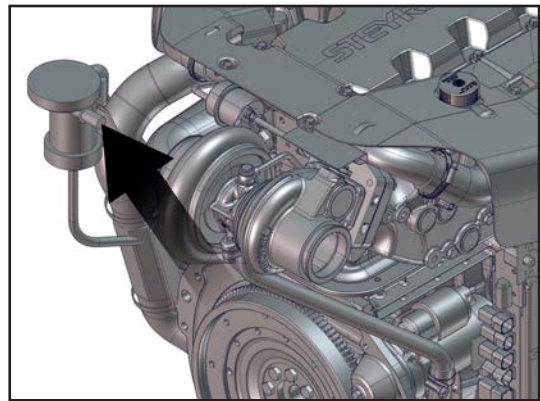

Fig. 96

## NOTICE

If engine has been run with raw water, flush raw water system with nontoxic, environmental-friendly antifreeze such as propylene glycol before storage.

Sticker

## NOTICE

Register preservation with commissioning: send e-mail to: [commissioning@steyr-motors.com](mailto:commissioning@steyr-motors.com)



Fig. 97

28. The engine is now preserved for one more year.  
 This procedure is repeatable up to a maximum of two times, giving a shelf life of up to three years.

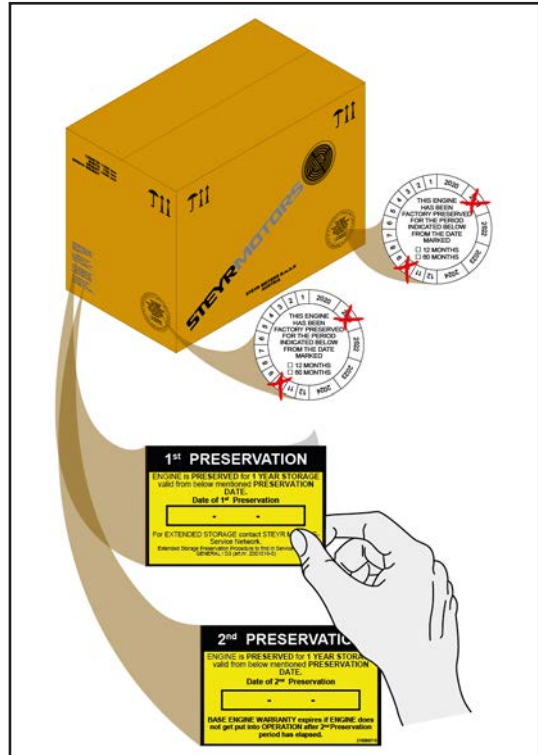

Fig. 98

**NOTICE**

When commissioning or running an engine that has been preserved as stated above the engine will run roughly and smoke for the first few minutes. Do not be alarmed as this is normal until the deposits of the preservation materials have cleared.

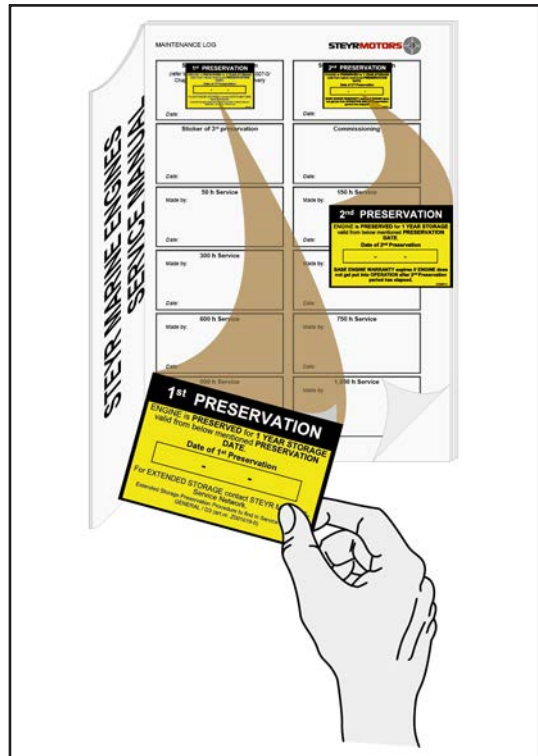

Fig. 99

#### 4.5.2 2<sup>nd</sup> Preservation

1. Change engine oil and engine oil filter as described in service manual.
2. Drain and refill closed cooling system with fresh coolant.
3. Reinstall air filter.

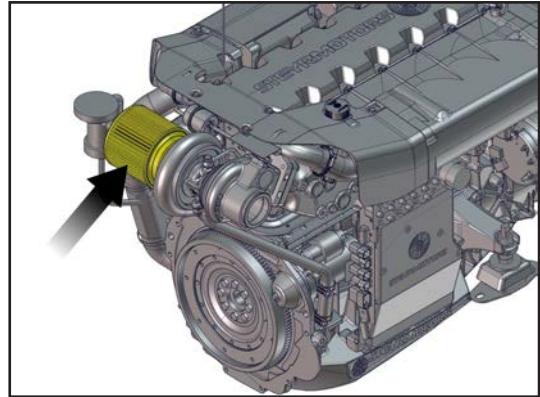

Fig. 100

Follow the steps 1st Preservation procedure, refer to “4.5.1.1 1st Preservation procedure”.

### **NOTICE**

See maintenance and service parts list for model specific part numbers and quantities!

<https://www.steyr-motors.com>

- Oil filter
  - Fuel filter
  - Steyr Motors engine oil
- 

Sticker

### **NOTICE**

Register preservation with commissioning e-mail to: [commissioning@steyr-motors.com](mailto:commissioning@steyr-motors.com)

---

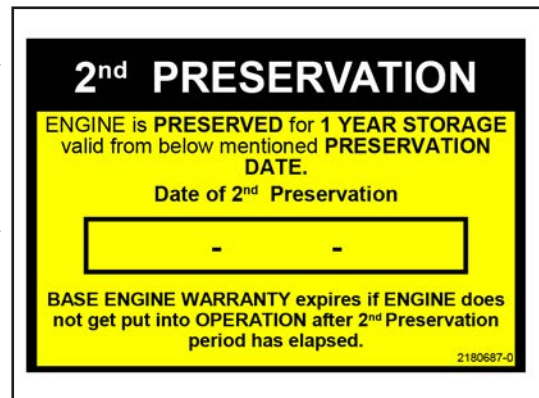

Fig. 101

## 4.5.3 De-preservation

### 4.5.3.1 De-preservation

### **NOTICE**

See maintenance and service parts list for model specific part numbers and quantities!

<https://www.steyr-motors.com>

- Oil filter
  - Fuel filter
  - Steyr Motors engine oil
-

### 4.5.3.2 De-preservation procedure

- Install engine as per instructions in installation guide, confirm the following:
  1. Connect instrument panel.
  2. Remove protection caps.
  3. Fit new fuel filter.

---

#### **NOTICE**

Fill fuel filter with fresh clean diesel before fitting!

---

4. Fuel system connected and primed with fresh clean diesel.
5. Connect battery cable.
6. Reinstall raw water pump impeller in raw water pump.

---

#### **NOTICE**

If cracks or damage is visible install **new** impeller!

---

7. Reinstall raw water pump.
8. Reinstall air filter.

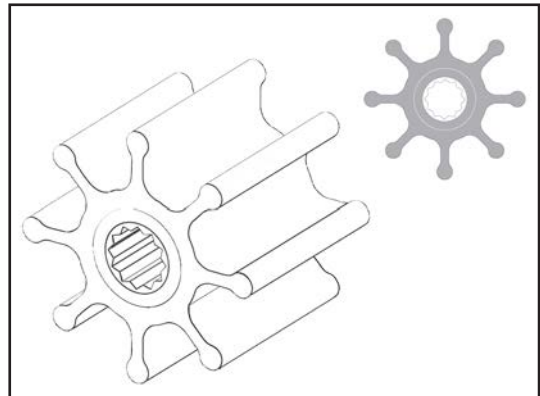

Fig. 102

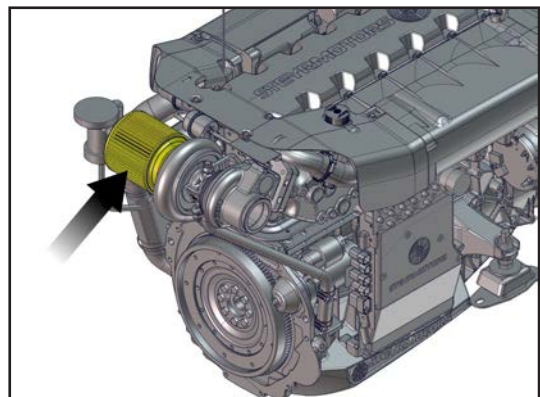

Fig. 103

9. Reinstall poly-v belt.



Fig. 104

10. Connect fuel return line to separate small fuel canister.

11. Turn ignition "On" 10 seconds three times. Allow fuel rail and engine mounted fuel filter to fill with fresh clean Diesel.

12. Reconnect fuel return line to fuel tank return.

13. Run engine at idle or maximum 1500 rpm to obtain operating temperature.

14. Replace oil filter.

15. Change engine oil as described in service manual.

16. For new or used engines always follow "Engine break-in procedure" as specified in operators manual after de-preservation.

For new engines proceed with sea-trials and commissioning procedure.

**G Operating and auxiliary materials**

Order number	Short text	SMO item	Alternative item
10084-0	Hot bearing grease	Staburags NBU4	
11104	Engine oil	Mobil Delvac 1350	
12222	Copper grease	Staloc® copper paste	
12385	Ultra Clean	Ultra Clean Techn. quick detergent	
50143	Diesel fuel acc. to EN 590	SADK (CFPP max. -30°C) B0	
500830	Engine oil	ACEA-, API-Service codes 10W-40	
500831	Engine coolant pink	SMO Coolant Premium Ready Mix R40-G (-40 °C)	
700429	Protection wax	BERNER Nr. 42910 400 ml-Spray	
702280	Lubricant	Staloc® Blue Moly 500 g	
705442	Injector grease	Tube 20 g	
706992	PTFE-Special grease	Bottle 500 g	
707656	High performance lubricant HT-7	Staloc® HT-7 (500ml)	
9000017-0	Screw lock compound, high strength	Staloc® 2S62 (red)	Loctite® 262 (red)
9000019-0	Seat sealing compound, high temperature	Staloc® 6S20 (green)	Loctite® 620 (green)
9000059-0	Screw lock compound, medium	Staloc® 2S43 (blue)	Loctite® 243 (blue)
9000297-0	Surface sealing compound, medium strength, flexible	Staloc® 5S18 (red)	Loctite® 518 (red) Loctite® 5182 (red)
9000510-0	Surface sealing compound, black	Staloc® Silicone sealant	Loctite® 5900 (black)
9000540-0	Two component adhesive	Staloc® Power 703	



---

## NOTE

Steyr Motors AG reserves the right to publish the latest Version of the Limited Engine Warranty Conditions under following link to Steyr Motors Homepage: <https://www.steyr-motors.com>

---

## W Warranty

### W 1 STEYR MOTORS LIMITED ENGINE WARRANTY

Steyr Motors AG (“Steyr Motors”) warrants to the original retail purchaser of a product covered under this Warranty (“the Product”), and to any other person to whom the Product is transferred during the duration of this Warranty, that in the event of a failure of the Product occurring during the applicable warranty period resulting from a defect in materials or factory workmanship, Steyr Motors will, at its option, repair or replace the defective Product according to the terms and conditions set forth herein.

#### Products Warranted

This Limited Warranty applies to all new marine engines manufactured by Steyr Motors and sold by Steyr Motors or by a Steyr Motors approved distributor or dealer until such time as this Warranty may be subsequently updated or revised. This Warranty also applies to the following engine accessories when approved and supplied by Steyr Motors and when installed by Steyr Motors or by a Steyr Motors approved distributor or dealer. Approved distributor or dealer as stated in Steyr Motors Service Network (refer to website at [www.steyr-motors.com](http://www.steyr-motors.com)).

This Warranty does not apply to any component manufactured by a third party and supplied by Steyr Motors as part of a package. Such non-covered components include, but are not limited to, any MerCruiser Bravo Series stern drive, ZF Marine transmissions, sail drives, water jet and commander systems, etc., that may be sold together with a Steyr engine. Buyers of a package that includes a MerCruiser Bravo Series stern drive should consult the product literature accompanying the stern drive for details on the warranty provided by its manufacturer, Mercury Marine. The provided warranty registration card with the Mercury Marine/MerCruiser product needs to be returned to Steyr Motors for registration in their system.

#### Warranty Registration Activation

**IMPORTANT: In order to obtain the full benefit of this Warranty, your new Steyr engine(s) must be timely registered at the factory, latest within three (3) years from the date of the sales document.**

Three (3) years is the maximum possible duration of warranty coverage extension provided that the required storage, preservation, and commissioning procedures are completed and submitted to Steyr Motors.

It is your responsibility to ensure that the Steyr Motors distributor, dealer, or OEM from whom you purchased the engine(s), registers your engine(s) at Steyr Motors. A copy of the

### **NOTE**

Steyr Motors AG reserves the right to publish the latest Version of the Limited Engine Warranty Conditions under following link to Steyr Motors Homepage: <https://www.steyr-motors.com>

---

Warranty Approval Certificate must be given to you immediately after the document has been received by the selling Steyr Motors distributor, dealer, or OEM. For a Warranty Approval Certificate to be issued a Commissioning Report must be submitted to Steyr Motors by the seller.

If an engine does not get put into operation within the first year from production, the Steyr Motors extended storage preservation procedure must be followed and documented as described in this procedure to prove proper storage, handling, and re-commissioning of the product.

**Failure to register the Product with Steyr Motors within 60 days of the date on which the Product is commissioned will cause the warranty period to begin running from the date on which the Product is shipped from Steyr Motors in Austria, rather than on the date of delivery to you.**

It is to your benefit to have all Products timely registered at Steyr Motors so that you receive the maximum available coverage under the Warranty and so that a Steyr Motors distributor has a means of identifying and contacting you in the event of product updates or service notifications.

#### *Commissioning Report*

It is the seller's (STEYR MOTORS distributor, dealer or OEM) responsibility to send a completed Commissioning Report to Steyr Motors factory for a successful warranty registration of the engine(s). Once accepted, Steyr Motors will provide a Warranty Approval Certificate of which the selling dealer must provide to the owner.

### **Base Engine Warranty**

The Base Engine Warranty covers any failure of the Product under normal use and service that occurs during the applicable period of coverage and that results from a defect in Steyr Motors material or factory workmanship (a "Warrantable Failure").

#### *Steyr Motors' Responsibilities under the Base Engine Warranty*

During the applicable period of coverage under the Base Engine Warranty, and subject to all conditions, limitations and exclusions herein, Steyr Motors will, at its option, either repair or replace the defective Product. In the event that Steyr Motors elects to repair the Product, Steyr Motors will do the following:

- Steyr Motors will pay for all parts and labor reasonably required to repair the defect responsible for the Warrantable Failure.
- Steyr Motors will pay for all lubricating oil, antifreeze, filter elements, and other similar maintenance items replaced during a warranty repair when such items are not reusable due to a Warrantable Failure.
- Steyr Motors will pay for the usual and customary labor costs for engine removal and reinstallation when necessary to repair a Warrantable Failure.

---

**NOTE**

Steyr Motors AG reserves the right to publish the latest Version of the Limited Engine Warranty Conditions under following link to Steyr Motors Homepage: <https://www.steyr-motors.com>

---

Labor costs will be paid by Steyr Motors only for work pre-authorized by Steyr Motors and performed by an approved service facility during normal business hours. Labor costs will be paid in accordance with Steyr Motors' published standard repair time guidelines. Parts used in warranty repairs may be new Steyr Motors parts, Steyr Motors-approved rebuilt parts, or repaired parts.

*Duration of Coverage*

The duration of coverage under the Base Engine Warranty is 12 months or until the engine has been operated for 300 hours, whichever comes first. The period of coverage commences on the date on which the Product is dispatched from Steyr Motors to the first retail purchaser.

The commencement of the Base Engine Warranty is delayed upon acceptance of a commissioning report within the initial 12-month Base Engine Warranty Period provided the engine has less than 30 operating hours at time of commissioning. Once the engine is commissioned, the duration of the Base Engine Warranty depends upon whether your engine application and use are rated for "Pleasure Duty" or for "Commercial Duty".

- For engines rated "Pleasure Duty (PL)," the Base Engine Warranty extends for a period of 24 months from commissioning or until the engines have been operated for 300 hours, whichever occurs first.
- For engines rated "Commercial or Government Duty," the Base Engine Warranty extends for a period of 12 months or until the engines have been operated for the maximum allowable yearly operating hours\*, whichever occurs first.

**\*Maximum Allowable Yearly Operating Hours**

Commercial High Output Duty (HO):	300 hours
Commercial Intermittent Duty (INT):	1500 hours
Commercial Medium Continuous Duty (MCD):	3000 hours

### **NOTE**

Steyr Motors AG reserves the right to publish the latest Version of the Limited Engine Warranty Conditions under following link to Steyr Motors Homepage: <https://www.steyr-motors.com>

---

### **Extended Major Components Warranty**

The Extended Major Components Warranty covers any failure under normal use and service of any of the below-listed parts or castings<sup>1</sup> that occurs during the extended warranty period and that is caused by a defect in material of original manufacturer:

- Engine Monoblock Casting
- Engine Camshaft
- Engine Crankshaft
- Engine Connecting Rods
- Crankshaft Sprocket
- Camshaft Sprocket
- Engine Housing
- Flywheel Housing

#### *Steyr Motors' Responsibilities under the Extended Major Components Warranty*

During the applicable period of coverage under the Extended Major Components Warranty, and subject to the conditions, limitations, and exclusions herein, Steyr Motors will, at its option, either repair or replace the defective component. Steyr Motors' responsibilities in the event of a repair shall be the same as provided with respect to the Base Engine Warranty, except that the cost of labor for removal and reinstallation is not covered under the Extended Major Components Warranty.

#### *Duration of Coverage for Specific Major Engine Components*

The Extended Major Components Warranty extends for a period of 60 months or until the engine has been operated for 1,800 hours, whichever occurs first. As with the Base Engine Warranty, the period of coverage commences on the date on which the Product is delivered to the first retail purchaser or on the date on which the unit is first commissioned or when the Product has been operated for 30 hours, whichever occurs first.

---

<sup>1</sup>Bushing and bearing failures are not covered.

**NOTE**

Steyr Motors AG reserves the right to publish the latest Version of the Limited Engine Warranty Conditions under following link to Steyr Motors Homepage: <https://www.steyr-motors.com>

**Summary of Warranty Coverage**

Type of coverage	Coverage Duration		Repair costs paid by Steyr Motors		
	Months*	Hours*	Parts	Labor	Removal & Reinstallation Labor
Base Engine Warranty <sup>2</sup>	12	300	Yes	Yes	Yes
Base Engine Warranty -- Pleasure Duty (PL)	24	600 <sup>3</sup>	Yes	Yes	Yes
Base Engine Warranty -- High Output Duty (HO)	12	300	Yes	Yes	Yes
Base Engine Warranty -- Intermittent Duty (INT)	12	1,500	Yes	Yes	Yes
Base Engine Warranty -- Medium Continuous Duty (MCD)	12	3,000	Yes	Yes	Yes
Extended Major Components Warranty	60	1,800	Yes	Yes	No

\*Whichever occurs first.

<sup>2</sup>Commences when the Product is dispatched from Steyr Motors.

<sup>3</sup>300 hours per year.

**Additional Coverage for Parts Replaced or Repaired Under Warranty**

Any Steyr Motors product or part replaced or repaired under the Base Engine Warranty will be covered under the Base Engine Warranty for the remaining period of warranty.

**Warranty Coverage for Genuine Spare Parts**

Steyr Motors warrants genuine spare parts for extent of 6 month beginning from the date of repair. The original invoice or delivery note must be provided to Steyr Motors for warranty coverage.

**Conditions of Warranty Coverage**

This Warranty is expressly conditioned upon proper application, installation, commissioning, operation, and maintenance of the Product in accordance with the specifications and guidelines set forth by Steyr Motors in its Installation, Operations, and Service Manuals. Proper use and operation of the Product entails, among other things, use of the Product in strict compliance with the following power ratings:

### **NOTE**

Steyr Motors AG reserves the right to publish the latest Version of the Limited Engine Warranty Conditions under following link to Steyr Motors Homepage: <https://www.steyr-motors.com>

---

#### *Pleasure Duty according to Marine Duty Rating*

Engines rated “Pleasure Duty” may not be used for any commercial application without voiding the product warranty. A “commercial or governmental application” includes any work or employment-related use of the Product, or any use of the Product that creates income, even if the Product is only occasionally used for such purpose. A “commercial application” also includes charter, naval, police, and other similar applications.

#### **Pleasure Duty Rating (PL)**

This power rating is intended for use in variable load applications where full power is limited to one (1) hour out of every eight (8) hours of operation. Reduced power operations must be at or below cruise speed (rpm). Cruise speed (rpm) is 200 rpm below the engine rated speed (rpm). Also, the defined propped speed range must be met and is specified in table propped speed range (Operator Manual, chapter Propeller Selection) for each engine model. This rating (ISO3046 Fuel Stop Power Rating) is for applications operating less than 300 hours per year and is intended exclusively for pleasure/non-revenue generating applications.

#### *Commercial or Governmental Duty according to Marine Duty Rating.*

If an engine is intended to be used for commercial operation, the application must comply with below described duty rating conditions. The duty ratings are defined in three different engine operation patterns and annual use of the unit. The operation pattern defines a ratio between full power-speed-range and cruising-speed-range, wherein cruising speed must be maintained on a specified reduced rpm below the engine rated speed. The specified reduced speeds are mentioned in the Marine Duty Ratings below.

#### **High Output Duty Rating (HO)**

This power rating is intended for intermittent use in variable load applications where full power is limited to one (1) hour out of every eight (8) hours of operation. Reduced power operations must be at or below cruise speed (rpm). Cruise speed (rpm) is 300 rpm below the engine rated speed (rpm). Also, the defined propped speed range must be met and is specified in table propped speed range (Operator Manual, chapter Propeller selection) for each engine model. This rating (ISO3046 Fuel Stop Power Rating) is for application operating less than 300 hours per year.

#### **Intermittent Duty Rating (INT)**

This power rating is intended for intermittent use in variable load applications where full power is limited to two (2) hours out of every eight (8) hours of operation. Reduced power operations must be at or below cruise speed (rpm). Cruise speed (rpm) is 200 rpm below the engine rated speed (rpm). Also, the defined propped speed range must be met and is specified in table propped speed range (Operator Manual, chapter Propeller selection) for each engine model. This rating (ISO3046 Fuel Stop Power Rating) is for application operating less than 1,500 hours per year.

## NOTE

Steyr Motors AG reserves the right to publish the latest Version of the Limited Engine Warranty Conditions under following link to Steyr Motors Homepage: <https://www.steyr-motors.com>

---

### Medium Continuous Duty Rating (MCD)

This power rating is intended for intermittent use in variable load applications where full power is limited to three (3) hours out of every twelve (12) hours of operation. Reduced power operations must be at or below cruise speed (rpm). Cruise speed (rpm) is 400 rpm below the engine rated speed (rpm). Also, the defined propped speed range must be met and is specified in table propped speed range (Operator Manual, chapter Propeller selection) for each engine model. This rating (ISO3046 Fuel Stop Power Rating) is for application operating less than 3,000 hours per year.

### Owner's Warranty Responsibilities

Steyr Motors' duty of performance under this Warranty is expressly conditioned upon the purchaser's maintenance of the following documentation and records which must be made available to Steyr Motors in the event that warranty service is required:

- You are responsible for keeping complete and accurate records of all services performed on the engine and for maintaining a log of all regularly scheduled maintenance in the Owner Service Log included in your Operations Manual.
- You are responsible for assuring that at all times the engine hour meter on your Steyr engines is in good working order and in a condition that accurately reflects the total hours that the engine(s) has been operating.
- **You are responsible for keeping copies of the Warranty Approval Certificate.**

### Limitations and Exclusions

Steyr Motors is not responsible for any engine failure or other problem attributable in whole or in part to any of the following:

- Any application or installation inconsistent with Steyr Motors' published application and installation guidelines.
- Abuse or neglect, including but not limited to operation without adequate coolants or lubricants, over-fueling, over-speeding, lack of maintenance of cooling, lubricating or intake systems, improper storage, preservation, rust or corrosion, improper starting, warm-up, run-in or shutdown practices, or failures caused by incorrect oil or by water, dirt or other contaminants in the fuel or oil.
- Unauthorized modifications of the engine.
- Use of a service facility not approved by Steyr Motors, or use of parts not supplied or approved by Steyr Motors. For information on approved service partner in your area, please contact Steyr Motors or refer to the list of approved service facilities posted on Steyr Motors' website at [www.steyr-motors.com](http://www.steyr-motors.com).
- Prolonged or incorrect storage. Prolonged storage, for purposes of this Warranty, is storage for a period of over one (1) year from the date of shipment from the Steyr Motors factory.

### **NOTE**

Steyr Motors AG reserves the right to publish the latest Version of the Limited Engine Warranty Conditions under following link to Steyr Motors Homepage: <https://www.steyr-motors.com>

---

- Normal wear or wear out of parts.
- Faulty workmanship, whether or not performed by an approved dealer or distributor of Steyr Motors, and whether or not occurring in conjunction with a warranty repair.

Steyr Motors will not pay for any of the following costs, which shall be the sole responsibility of the Owner:

- The cost of transporting any Steyr Motors engine or product to or from the place of warranty service.
- The cost of haulage, launch, docking, or cranes.
- The cost of lubricating oil, antifreeze, filter elements, and other maintenance items replaced during warranty repairs unless such items are not reusable because of the Warrantable Failure.
- The cost of any part supplied, or labor performed, by a service facility not approved by Steyr Motors.
- The cost of any part supplied, or labor performed, by a service facility without the prior authorization of Steyr Motors.

Steyr Motors does not warrant any product or component not specifically identified in the “Products Warranted” section of this document. Please note in particular the following:

- Steyr Motors does not warrant any product or component not manufactured by Steyr Motors, except for those accessories specifically identified in the “Products Warranted” section of this document that are supplied by Steyr Motors and installed by Steyr Motors or by a Steyr Motors approved distributor or dealer. Examples of items not warranted are stern drives, sail drives, gear boxes, and water jets, commander systems, etc.
- Steyr Motors does not warrant maintenance components supplied by Steyr Motors after 90 days of the date on which warranty coverage commences. Maintenance components include, but are not limited to, sea water pump impellers, zinc plugs, oil filters, fuel filters, air filters, water filters, fuel/water separator filters, belts, automatic belt tensioner, timing belt and idler, gaskets, hoses, fuses, brushes and accommodator, fuel injection nozzle valves, expansion tank pressure caps, and thermostats.
- Steyr Motors products are not entitled to limited warranty coverage, if the Commissioning Report has not been submitted to / received by Steyr Motors within three (3) years from the date of manufacturing and required Preservations have not been applied if over 12 months from date of manufacture.

---

## NOTE

Steyr Motors AG reserves the right to publish the latest Version of the Limited Engine Warranty Conditions under following link to Steyr Motors Homepage: <https://www.steyr-motors.com>

---

Torsional vibration compatibility:

- Steyr Motors sells Kits comprising only parts of the propulsion system and is not responsible for the overall system. The party responsible for the overall propulsion system is responsible for ensuring torsional vibration compatibility of the system, especially for the torsional coupling.
- Steyr Motors cannot accept any liability for damage to the torsional coupling caused by undue torsional vibrations. It is required to carry out a torsional vibration analysis of the overall system to confirm the coupling selection.
- Steyr Motors can provide the required data for the parts sold by Steyr Motors. We can also organize a torsional vibration analysis carried out by the coupling manufacturer. The required data of the remaining propulsion system must be provided by the overall propulsion system responsible party. Feel free to contact our customer service department for support.

### **IN NO EVENT SHALL STEYR MOTORS BE RESPONSIBLE FOR INCIDENTAL OR CONSEQUENTIAL DAMAGES.**

Such excluded damages include, but are not limited to, loss of use (including “down time”), loss of income or business revenue, costs of travel, costs of transport, extra costs required to make the Product accessible as a result of particular vessel designs and/or installations (including the removal and/or replacement of partitions or material), personal injury, loss of property, cargo damage, fines, taxes, damages to parts or goods other than products specifically covered by this Warranty, and any other indirect or consequential loss resulting from a Warrantable Failure. Some states do not allow limitations on how long an implied warranty lasts, so the above limitation may not apply to you.

**The warranties set forth herein are the only warranties made by Steyr Motors with respect to the Product. No dealer or distributor of Steyr Motors is authorized to make any additional warranty, promise, or representation on behalf of Steyr Motors or to modify or extend the terms or duration of this warranty. Any warranty implied by law, including any implied warranty of merchantability or of fitness for a particular purpose, shall be limited in duration to the term of this warranty.**

### **Procedure for Making a Warranty Claim**

Warranty service may be obtained from any approved Steyr Motors distributor or dealer. For a list of approved service locations, please refer to Steyr Motors’ website at [www.steyr-motors.com](http://www.steyr-motors.com) or contact Steyr Motors’ Customer Service, the contact information for which is provided on the final page of this document.

In the event of a Warrantable Failure arising during the applicable warranty period, a warranty claim must be submitted promptly in writing to an SMO dealer / distributor. A warranty claim must be made immediately upon discovery of facts that would lead a reasonably

### **NOTE**

Steyr Motors AG reserves the right to publish the latest Version of the Limited Engine Warranty Conditions under following link to Steyr Motors Homepage: <https://www.steyr-motors.com>

---

prudent owner to believe that the Product is defective in materials or factory workmanship, but in no event more than 30 days after such discovery. The SMO dealer / distributor must submit a warranty claim to Steyr Motors within this 30-day time period.

In case of a warranty claim, please contact any approved Steyr Motors distributor or dealer.

A Steyr Motors Warranty Claim Form (a sample copy of which is available from Steyr Motors' website at [www.steyr-motors.com](http://www.steyr-motors.com)) must be completed by the dealer or distributor and returned to Steyr Motors in Austria. It is your responsibility to ensure that the Warranty Form is properly completed and to retain a copy for your records as proof of the making of a timely warranty claim.

All warranty claims must be approved by Steyr Motors before any warranty work is undertaken. No distributor or dealer of Steyr Motors is authorized to approve, or to guarantee approval of, a warranty claim. Any work performed prior to obtaining authorization from Steyr Motors will be at the risk of the owner and/or service facility undertaking the work. Upon approval of a warranty claim, you are responsible for making the Product available for repair at the place designated by Steyr Motors within a reasonable period of time.

**IMPORTANT: The foregoing procedures for making a warranty claim are mandatory. Failure to comply with the requirements for submitting a warranty claim shall be presumed to have deprived Steyr Motors of adequate and timely notice of a defect and shall relieve Steyr Motors of any duty of performance under this Warranty.**

### **Venue and Applicable Law**

This Limited Warranty and the rights and obligations of Steyr Motors and of the Owner as they relate to any product supplied by Steyr Motors shall be governed by and construed in accordance with Austrian law, and any legal action instituted against Steyr Motors as a result of this Warranty shall be brought in Vienna, Austria. In the event of a legal action commenced against Steyr Motors in the United States, Steyr Motors shall have the option to consent to jurisdiction and to require that the action be submitted to binding arbitration according to the commercial rules of the American Arbitration Association.

### **Miscellaneous**

This Warranty document consists of the complete and final expression of the intent of the parties with respect to the warranty obligations of Steyr Motors. The terms of this Warranty may not be modified except by a writing signed by an authorized representative of Steyr Motors. Dealers and distributors of Steyr Motors engines (whether or not approved by Steyr Motors) are not agents of Steyr Motors and have no authority to alter the terms of this Warranty or to waive any condition or requirement stated herein.

**NOTE**

Steyr Motors AG reserves the right to publish the latest Version of the Limited Engine Warranty Conditions under following link to Steyr Motors Homepage: <https://www.steyr-motors.com>

Should any portion of this Warranty be determined unenforceable in a court of law, the validity and legal effect of the remainder of the document shall not be affected. Steyr Motors may in certain circumstances, and at its sole discretion, provide for service outside the scope of this Warranty to update, modify, or repair a product. In that event, Steyr Motors shall not be deemed to have assumed any additional obligation to the owner or to have modified or waived any of the provisions of this Warranty.

The owner shall be responsible for the cost of investigating complaints found not to be attributable to a defect in Steyr Motors material or factory workmanship.

Any Steyr Motors product or part replaced under warranty will automatically become the property of Steyr Motors.

**This warranty gives you specific legal rights, and you may also have other rights which vary from state to state.**

**If You Do Not Receive Satisfactory Warranty Service**

Steyr Motors strives, through an extensive network of independent distributors and dealers, to provide prompt, courteous, and competent warranty service to owners of Steyr engines. If you fail to receive satisfactory warranty service from a Steyr Motors distributor or dealer, please contact Steyr Motors Customer Service directly. Contact information is as follows:

**Customer Service**  
 Steyr Motors AG  
 Im Stadtgut B1, 4407 Steyr, Austria

Phone: +43 7252 222-52  
 E-mail: [technical@steyr-motors.com](mailto:technical@steyr-motors.com)

Erstellt / Issued: 15.06.2016 Bearbeitet / Edited: 10.12.2019, 06.03.2020, 06.08.2024 Kundendienst / Customer Service	Geprüft und freigegeben / Approved: 06.08.24 / CEO Julian Cassutti (Datum, Name / Date, Name)
--	---

### **W 2 U.S. EPA Emission control warranty** (valid only on U.S.-flagged vessels)

Steyr Motors warrants to the first retail purchaser and to each subsequent owner of a new Steyr Motors engine that all parts of its emission control system are:

1. Designed, built, and equipped so it conforms at the time of sale to the ultimate purchaser with all applicable U.S. Environmental Protection Agency regulations.
2. Free from defects in materials and workmanship that cause the engine to fail to conform to the applicable regulations for the warranty period set below.

**This warranty covers the following list of items that are considered a part of the emission control system if originally installed by Steyr Motors on the engine to comply with EPA regulations:**

- Turbocharger system
- Intercooler
- Exhaust manifold
- Fuel supply pump
- Unit injector
- ECU
- Engine Speed / Timing Sensor
- Coolant Temperature Sensor
- Intake Pressure Sensor
- Intake Manifold Temperature Sensor
- Fuel Pressure Sensor
- Closed Breather System
- Hoses, Clamps, Fittings, Tubing (whose failure affects exhaust emissions)
- Gaskets, Seals
- Emission Control Information Labels
- Air Cleaner\*, Fuel Filter Element\*

\*until the first scheduled replacement point.

The emission control parts listed above are subject to this warranty for 5 years or 5.000 hours, (whichever occurs first).

In case of a warrantable condition, Steyr Motors will repair your engine at no cost to you, including diagnosis, parts and labor.

The warranty shall begin as the Steyr Motors engine is handed over to the first retail purchaser.

Steyr Motors recommends using parts supplied or approved by Steyr Motors for repair, replacement, or maintenance, to ensure maximum emission compliance. Parts not supplied or approved by Steyr Motors may be of questionable quality and should only be used if equivalent.

This warranty does not cover the replacement of expendable maintenance parts such as exhaust systems, filters, hoses, belts, oil, thermostat, and coolant in connection with scheduled maintenance, once these parts have been replaced.

### Limitations and exclusions

Steyr Motors is not responsible for any product failure or other failure attributable in whole or in part to any of the following:

- Any application or installation inconsistent with Steyr Motors' published application and installation guidelines as well as damages caused by transportation.
- Non-compliance with the Operation, Maintenance and Warranty Manual and any other instructions and documentation supplied.
- Abuse or neglect including but not limited to the operation under a lack of adequate coolant or lubricants, over-fuelling, over-speeding, lack of maintenance, rust, or corrosion, improper starting, warm-up, run-in or shutdown procedures, failures caused by incorrect or contaminated oil, coolant or fuel, competition use, over- or under-loading, cavitation, accidents, breaking of seals, violation of laws and force majeure.
- Damage that is the result of sand, debris, or any other foreign material being drawn into the water pump and its components.
- Unauthorized modifications of the Product.
- Combination of the Product with any mechanical or electrical product or component not sold or approved by Steyr Motors.
- Service or repair procedures not authorized by Steyr Motors. For proper service and repair work and maximum performance of your Steyr Motors Product, please consult an authorized Steyr Motors partner.
- Use of spare parts not supplied or approved by Steyr Motors.
- Normal wear and tear.
- Faulty workmanship, whether or not performed by an authorized Steyr Motors partner and whether or not occurring in conjunction with a warranty repair.

STEYR MOTORS will NOT pay for any of the following costs:

- The costs of any part supplied, or work performed, by a service facility without the prior written approval of Steyr Motors.
- The costs for lubricating oil, coolant, filter elements, and other equivalent maintenance items replaced during a Warranty repair if such items are not reusable due to a Warrantable Failure.
- The costs for Product removal and reinstallation if necessary to repair a Warrantable Failure.
- The cost of haulage, launching, docking, cranes or storage.
- The transportation costs of a Steyr Motors Product to or from the place where work shall be performed.

## Warranty

---

- Costs to modify fuel systems or gear ratios to meet local altitude requirements.
- Travel to or from the Steyr Product by the authorized Steyr partner / approved service facility or transportation of the Steyr Product to and from the authorized Steyr partner / approved service facility; charges for towing, haulage, launch, storage, fuel, or lubricants usage, premium (air) freight charges; rental costs, and excessive time necessary to disassembly boat partitions, hatches, or decks to gain access.

Steyr Motors does not warrant any product or component not specifically identified in the “Products Warranted” section of this document. Please note in particular that STEYR MOTORS DOES NOT WARRANT:

- Maintenance components which include, but are not limited to, sea water pump impellers, zinc plugs, oil filters, fuel filters, air filters, water filters, fuel/water separator filters, belts, automatic belt tensioner, timing belt and idler, gaskets, hoses, fuses, brushes, regulators and commutators, expansion tank pressure caps, and thermostats.
- Steyr Products sold or transferred as part of an AS IS transaction without warranties.
- Steyr engines on which the hour meter has been disconnected or the hour record has been altered so the actual usage cannot be determined precisely.

IN NO EVENT SHALL STEYR MOTORS BE RESPONSIBLE FOR INCIDENTAL OR CONSEQUENTIAL DAMAGES AS WELL AS DAMAGES RESULTING FROM SLIGHT NEGLIGENCE. Such excepted damages include, but are not limited to, loss of use (including “down time”), loss of income or business revenue, costs of travel, costs of transport, extra costs required to make the Product accessible as a result of particular vessel designs and / or installations (including the removal and/or replacement of partitions or material), personal injury, loss of property, cargo damage, fines, taxes, damages to parts or goods other than products specifically covered by this Warranty and any other indirect or consequential loss resulting from a Warrantable Failure.

STEYR MOTORS DOES NOT MAKE ANY IMPLIED WARRANTY OF FITNESS FOR A PARTICULAR PURPOSE, AND THERE ARE NO WARRANTIES THAT EXTEND BEYOND THE DESCRIPTION ON THE FACE HEREOF.

IN THOSE JURISDICTIONS WHERE IMPLIED WARRANTIES MAY NOT BE DISCLAIMED, ANY IMPLIED WARRANTY IS LIMITED IN DURATION TO THE DURATION OF THE EXPRESS WARRANTIES DESCRIBED IN THIS WARRANTY STATEMENT. SOME STATES DO NOT ALLOW LIMITATIONS ON HOW LONG AN IMPLIED WARRANTY LASTS, SO THE ABOVE LIMITATIONS MAY NOT APPLY TO YOU.

THE REPAIR OR REPLACEMENT OF PARTS OR THE PERFORMANCE OF SERVICE UNDER THIS WARRANTY DOES NOT EXTEND THE LIFE OF THIS WARRANTY BEYOND ITS ORIGINAL EXPIRATION DATE.

**THE WARRANTIES SET FORTH HEREIN ARE THE ONLY WARRANTIES MADE BY STEYR MOTORS WITH RESPECT TO THE PRODUCT APART FROM ANY MANDATORY RIGHTS GRANTED BY LAW IN YOUR COUNTRY. NO AUTHORIZED STEYR MOTORS PARTNER IS AUTHORIZED TO MAKE ANY ADDITIONAL WARRANTY, PROMISE, OR REPRESENTATION ON BEHALF OF STEYR MOTORS OR TO MODIFY OR EXTEND THE TERMS OR DURATION OF THIS WARRANTY.**

Some states do not allow the exclusion or limitation of incidental or consequential damages, so the above limitation or exclusion may not apply to you. This warranty gives you specific legal rights; you may also have other rights that vary from state to state.

### **Warranty claim procedure**

Warranty service may be obtained from any authorized Steyr Motors partner / approved service facility. For a list please refer to Steyr Motors website at <https://www.steyr-motors.com>. In the event of a Warrantable Failure arising during the applicable Warranty period, a Warranty claim must be submitted to an authorized Steyr Motors partner immediately upon discovery of facts that would lead a reasonably prudent owner to believe that the Product is defective.

ALL WARRANTY CLAIMS MUST BE APPROVED BY STEYR MOTORS BEFORE ANY WARRANTY WORK IS PERFORMED. No authorized Steyr Motors partner is authorized to approve, or to guarantee approval of a Warranty claim. Any work performed prior to obtaining authorization from Steyr Motors will be at the risk of the authorized Steyr Motors partner / approved service facility undertaking the work.

### **Miscellaneous**

This Warranty document consists of the complete and final expression of the intent of the parties with respect to the Warranty obligations of Steyr Motors. The terms of this Warranty may only be modified in writing by Steyr Motors. Steyr Motors partners (whether or not approved by Steyr Motors) are not considered as legal agents of Steyr Motors and have no authority to alter the terms of this Warranty or to waive any condition or requirement stated herein. Steyr Motors may in certain circumstances, and at its sole discretion, provide for service outside the scope of this Warranty to update, modify, or repair a product. In that event, Steyr Motors shall not be deemed to have assumed any additional obligation to the owner or to have modified or waived any of the provisions of this Warranty. Any Steyr Motors product or part replaced under Warranty will on Steyr Motors' discretion become property of Steyr Motors.



**Steyr Motors AG**

Im Stadtgut B1 | A-4407 Steyr-Gleink | Austria

[www.steyr-motors.com](http://www.steyr-motors.com)