

# STEYR MOTORS MARINE ENGINES

## 4 CYLINDERS + 6 CYLINDERS

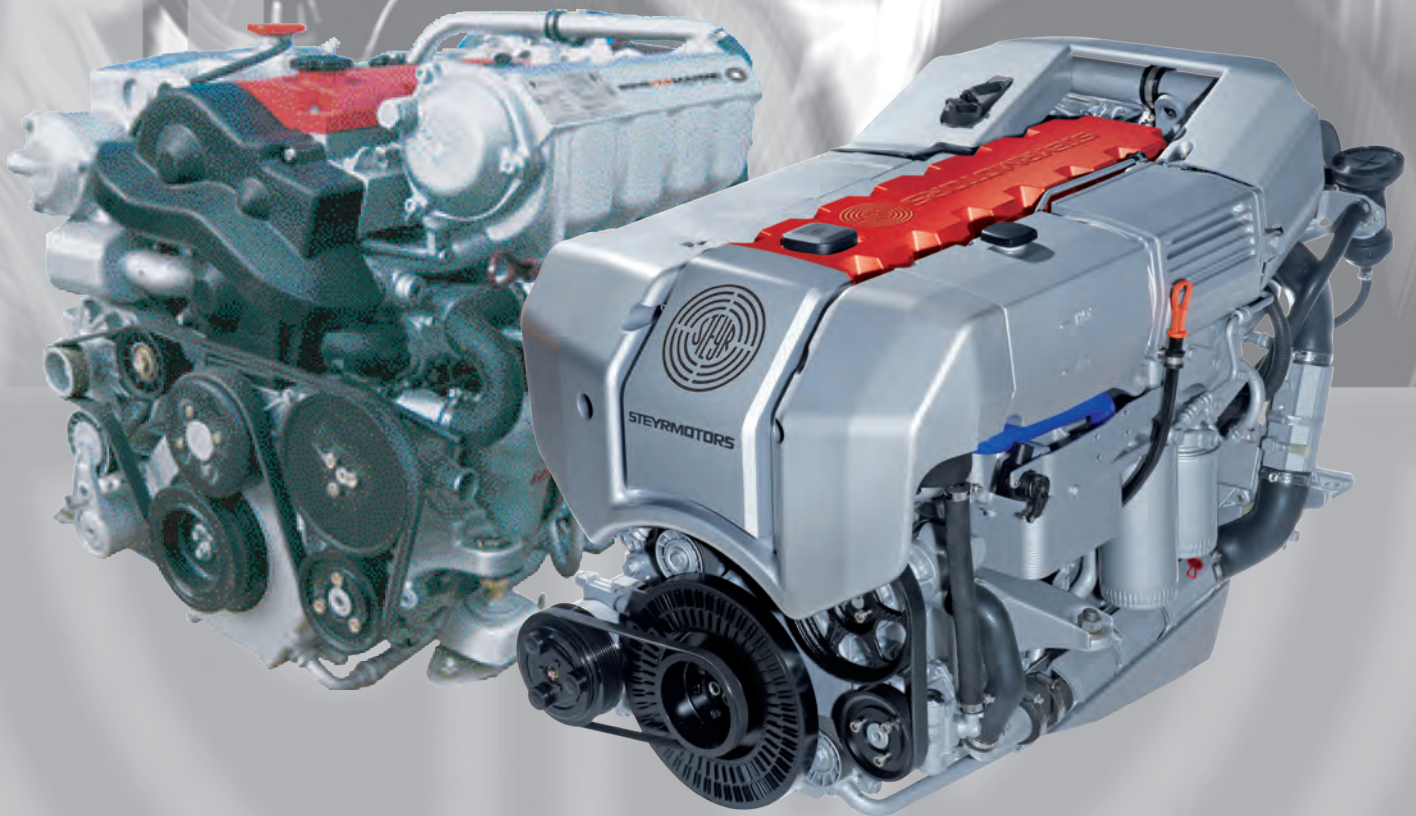

# OPERATION, MAINTENANCE AND WARRANTY MANUAL

P/N Z001140-0 9<sup>th</sup> Edition January 2023

**This Page is intentionally blank**

## WELCOME ABOARD



Congratulations on your decision of choosing a Steyr Motors marine engine for your boat, and we hope you will enjoy it.

Steyr Motors has developed a high-speed diesel engine with two stage high-pressure fuel injection specifically for the marine environment. Steyr Motors marine engines are designed to be adapted to various propulsion systems.

To come up to your expectations, please study thoroughly this manual for your new Steyr Motors marine engine to get sufficient information on its operation and handling and to permit an optimal use of the various built-in functions.

With kind regards,  
**Steyr Motors Betriebs GmbH**



**Steyr Motors Betriebs GmbH**  
**Customer Service**

**Im Stadtgut B1**  
**4407 Steyr, Austria**

**[www.steyr-motors.com](http://www.steyr-motors.com)**

YOUR STEYR MOTORS MARINE DEALER

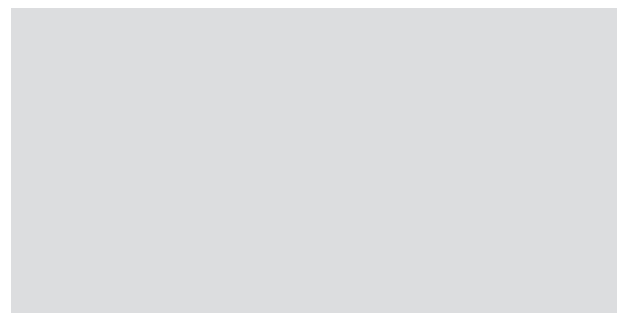

9<sup>th</sup> Edition, January 2023

P/N Z001140-0

**How to use this manual**

**Table of Contents**

**GENERAL PART** PAGE 10 - 21

This section contains user instructions and general notes on safety for Steyr Motors marine engines.

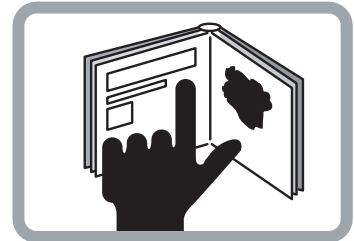

**START-UP AND FUNCTIONS** PAGE 22 - 51

This section contains brief instruction, function description and normal operation, as well as correct start-up and handling of Steyr Motors marine engines.

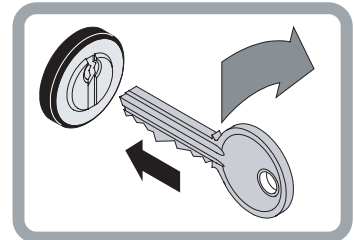

**FUEL AND LUBRICANTS** PAGE 52 - 55

This section defines the requirements as to fuel and lubricants for Steyr Motors marine engines.

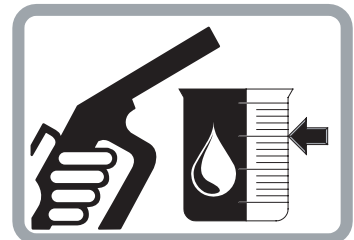

**TECHNICAL DATA** PAGE 56 - 65

This section contains technical data and product description of Steyr Motors marine engines.

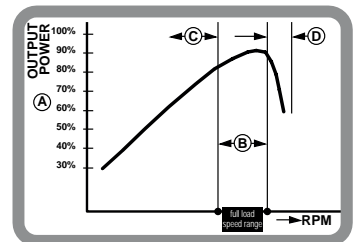

**MAINTENANCE, TROUBLE SHOOTING** PAGE 66 - 110

This section contains instructions for required maintenance and notes on the fault finding on your Steyr Motors marine engines.

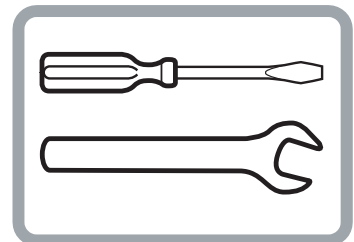

**DEALER'S RESPONSIBILITIES** PAGE 111 - 124

This section contains instructions for installation acceptance tests, propeller selection, removal from service, start-up after storage, adequate disposal and dealer's test list.

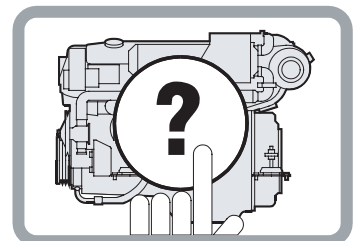

**WARRANTY** PAGE 125 - 139

This section contains warranty conditions (services and obligations) for owners and manufacturers of Steyr Motors marine engines.



**This page is intentionally blank**



## **SAFETY PRECAUTIONS**

Safety Precautions .....	7
Introduction.....	7



## Safety Precautions

### Introduction

This Operation, Maintenance and Warranty Manual contains the information you will need to operate the engine correctly. Check that you have the correct Operation, Maintenance and Warranty Manual for your engine.

Read the book carefully before operating or servicing the engine. Incorrect operation or servicing of the engine could result in personal injury or material damage as well as damaging the engine itself. If you do not understand or are uncertain on any operation in this book, contact your dealer who can explain or demonstrate the procedure for you.

Before starting work on the engine read the "Safety Precautions", of this manual carefully.



Immobilize the engine by turning off the power supply to the engine at the main switch (switches/breakers) and lock it (them) in the OFF position before starting work. Set up a warning notice at the engine control point or helm.

As a general rule all service operations must be carried out with the engine stopped. However, some work, for example certain adjustments require that the engine is running when they are carried out. Approaching an engine which is operating is a safety risk. Loose clothing or long hair can fasten in rotating parts and cause serious personal injury. If working in proximity of an engine which is operating, careless movements or a dropped tool can result in personal injury.

Take care to avoid contact with hot surfaces (exhaust pipes, turbocharger, air intake pipe, start element etc.) and hot liquids in lines and hoses on an engine which is running or which has just been stopped. Reinstall all protective parts removed during service operations before starting the engine.



Check that the warning or information labels on the engine are always clearly visible. Replace labels which have been damaged or painted over.



Engines with turbocharger: Never start the engine without installing the air cleaner filter. The rotating compressor in the turbo can cause serious personal injury. Foreign objects entering the intake ducts can also cause mechanical damage.

Never use start spray products or similar when starting the engine. They may cause an explosion in the inlet manifold. Danger of personal injury.



Avoid opening the filler cap for engine coolant system (freshwater cooled engines) when the engine is still hot. Steam or hot coolant can spray out. Open the filler cap slowly and release the pressure in the system. Take great care if a cock, plug or engine coolant line must be removed from a hot engine. Steam or hot coolant can spray out in any direction.

Hot oil can cause burns. Avoid getting hot oil on the skin. Ensure that the lubrication system is not under pressure before carrying out any work. Never start or operate the engine with the oil filler cap removed, otherwise oil could be ejected.



Stop the engine and close the sea cock before carrying out operations on the engine cooling system.



Only start the engine in a well-ventilated area. If operating the engine in an enclosed area ensure that there is exhaust ventilation leading out of the engine compartment or workshop area to remove exhaust gases and crankcase ventilation emissions.

Always use protective glasses or goggles when carrying out work where there is a risk of splinters, grinding sparks, acid splashes or where other chemicals are used. The eyes are extremely sensitive, an injury could result in blindness!



Avoid getting oil on the skin! Repeated exposure to oil or exposure over a long period can result in the skin becoming dry. Irritation, dryness and eczema and other skin problems can then occur. Used oil is more dangerous than fresh oil from a health aspect. Use protective gloves and avoid oil soaked clothes and shop rags. Wash regularly, especially before eating. There are special skin creams which counteract drying out of the skin and make it easier to clean off dirt after work is completed.

Many chemicals used on the product (for example engine and transmission oils, glycol, gasoline and diesel oil), or chemicals used in the workshop (for example degreasing agents, paint and solvents) are dangerous to health. Read the instructions on the product packaging carefully! Always follow the safety precautions for the product (for example use of protective mask, glasses, gloves etc.). Make sure that other personnel are not exposed to hazardous chemicals, for example in the air. Ensure good ventilation in the work place. Follow the instructions provided when disposing of used or leftover chemicals.



Exercise extreme care when leak detecting on the fuel system and testing the fuel injector jets. Use eye protection. The jet from a fuel injector nozzle is under extremely high pressure and has great penetrative energy, so the fuel can penetrate deep into the body tissue and cause serious personal injury. Danger of blood poisoning.



All fuels and many chemical substances are flammable. Do not allow naked flame or sparks in the vicinity. Fuel, certain thinner products and hydrogen from batteries can be extremely flammable and explosive when mixed with air.

Smoking is not to be permitted in the vicinity!

Ensure that the work area is well ventilated and take the necessary safety precautions before starting welding or grinding work. Always ensure that there are fire extinguishers at hand when work is being carried out.



Ensure that rags soaked in oil or fuel and used fuel or oil filters are stored safely. Rags soaked in oil can spontaneously ignite under certain circumstances. Used fuel and oil filters are environmentally dangerous waste and must be deposited at an approved site for destruction together with used lubricating oil, contaminated fuel, paint remnants, solvent, degreasing agents and waste from washing parts.

Never expose a battery to naked flame or electrical sparks. Never smoke in proximity to the batteries. The batteries give off hydrogen gas during charging which when mixed with air can form an explosive gas -oxyhydrogen. This gas is easily ignited and highly volatile. Incorrect connection of the battery can cause a single spark which is sufficient to cause an explosion with resulting damage. Do not shift the connections when attempting to start the engine (spark risk) and do not lean over any of the batteries.



Always ensure that the Plus (positive) and Minus (negative) battery leads are correctly installed on the corresponding terminal posts on the batteries. Incorrect installation can result in serious damage to the electrical equipment. Refer to the wiring diagrams.



Always use protective goggles when charging and handling the batteries. Battery electrolyte contains sulfuric acid which is highly corrosive. Should the battery electrolyte come into contact with unprotected skin wash off immediately using plenty of water and soap. If battery acid comes in contact with the eyes, immediately flush with plenty of water and obtain medical assistance at once.



Turn the engine off and turn off the power at the main switch(es) before carrying out work on the electrical system.

Clutch adjustments must be carried out with the engine stopped.



## GENERAL PART

General.....	11
Marine 4 Cyl Engines Overview .....	12
Marine 6 Cyl Engines Overview .....	13
Product References, Illustrations and Specifications .....	15
Insurance.....	15
Stolen Unit.....	15
Warranty Declaration, Emission Related Warranty .....	16
Warranty Registration Approval.....	16
Dealer Service - Maintenance .....	16
Illustration Symbols .....	16
Repair Service.....	17
Replacement Parts.....	17
Before Casting Off.....	17
Engine Submersion .....	18
Bottom Painting .....	18
Boat Bottom.....	18
Boating Responsibilities .....	19
Safety .....	19
WARNING .....	19
Symbols.....	20

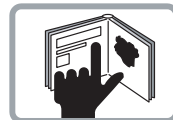

**General**

This manual is published by Steyr Motors Betriebs GmbH with the main intention to provide information in form of technical data and know-how based on our experience in the marine diesel engine business, which will enable you, after thorough study to operate and check the engines on your boat, ensuring their operating safety, reliability and long service life.

**CE Conformity:**

Under regular maintenance, as described in the chapter “Maintenance and Trouble Shooting”, the exhaust gas emission levels adhere to the limits stipulated, for pleasure boat operation, throughout the life time of the engine.

**Limited Application (US only):**

Ship-owners or boat builders intending to purchase and install a Steyr Motors marine engine in a vessel which will be used in ECA (Emission Control Areas) and which are not excluded from IMO Tier III in accordance with Annex VI regulation 13.1.2, must contact the EPA and the US Coast Guard to request an exception from IMO Tier III in accordance with Annex VI Regulation 13.5.2.2 using engines with an EPA Tier 3 / IMO MARPOL 73/78 Tier II approval.

Regarding the Steyr Motors Limited Engine Warranty please refer to the Steyr Motors website:

<http://www.steyr-motors.com/>.

All warranty claims to be addressed to your local Steyr Motors Marine Dealer.

(We have to rely on your assistance however) For continuous improvement with regard to form and contents of the information required.

Your comments on the following questions would be much appreciated

- Which descriptions or terms are not understandable?
- Which enlargements or complements do you suggest?
- Where did content-related mistakes slip in?

Please address your comments and ideas to your Steyr Motors- Marine Dealer.

Since this manual covers the whole family of Steyr Motors marine engines, differing sections are marked as follows:

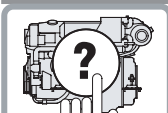
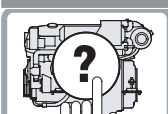
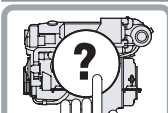
	<b>1.)</b>
<i>whole page applies to all engines</i>	
	<b>2.)</b>
MO144K33	
<i>whole page applies to specified engine types only</i>	
	<b>3.)</b>
GENERAL	
MO114K33	< 3700 rpm
<i>whole page applies in principle for all engine types, but different data, e. g. technical data, is marked.</i>	



## Marine 4 Cyl Engines Overview

MO & SE 4-cylinder engine models						
engine type	number of cylinders	displacement [cm <sup>3</sup> ]	rated power [kW]	rated speed (rpm)	Propeller selection range (rpm)	Jet selection range (rpm)
MO84K32	4	2100	55	3200	3000-3200	/
MO94K33	4	2100	66	3300	3100-3300	/
MO114K33	4	2100	81	3300	3100-3300	/
MO144M38	4	2100	106	3800	3500-3800	/
MO164M40	4	2100	120	4000	3700-4000	/
MO174V40	4	2100	125	4000	3700-4000	/
SE144E38	4	2133	106	3800	3700-3900	3300-3800
SE164E40	4	2133	118	4000	3900-4100	3550-4000

MO & SE 4-cylinder engine models					
engine type	dry weight (kg)	Fuel cons @ rated power (kg/h)	MAP [mbar]	compression ratio	max. exhaust backpressure (mbar)
MO84K32	243	14,2	1900	$\epsilon = 17,5$	100
MO94K33	243	17,5	1900	$\epsilon = 17,5$	100
MO114K33	255	18,6	1900	$\epsilon = 17,5$	100
MO144M38	258	26,8	/	$\epsilon = 17,5$	100
MO164M40	258	31,6	2740	$\epsilon = 17,5$	100
MO174V40	276	33,4	3100	$\epsilon = 17,0$	150
SE144E38	263	27	2520	$\epsilon = 17,0$	150
SE164E40	263	29,7	2650	$\epsilon = 17,0$	150

MO & SE 4-cylinder engine models					
engine type	backpressure tolerance (mbar)	max. engine cooling water outlet temp (°C)	max. engine coolant outlet temperature (°C)	Oil filling quantity [lt.]	Coolant water quantity [lt.]
MO84K32	+/-50	/	/	8,4	9,0
MO94K33	+/-50	/	/	8,4	9,0
MO114K33	+/-50	/	/	8,4	9,0
MO144M38	+/-50	/	/	8,4	9,0
MO164M40	+/-50	/	/	8,4	9,0
MO174V40	+0/- 50	/	/	8,4	9,0
SE144E38	+0/- 50	83	105	8,75	10,7
SE164E40	+0/- 50	83	105	8,75	10,7

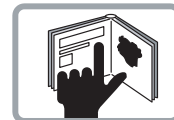

## Marine 6 Cyl Engines Overview

SE 6-cylinder engine models						
engine type	number of cylinders	displacement [cm <sup>3</sup> ]	rated power [kW]	rated speed (rpm)	Propeller selection range (rpm)	Jet selection range (rpm)
SE126E25	6	3200	88	2500	2300-2550	/
SE156E26	6	3200	110	2600	2400-2650	/
SE156E32	6	3200	110	3200	3000-3250	/
SE156E34	6	3200	110	3400	3200-3500	/
SE196E35	6	3200	140	3500	3300-3550	/
SE236E40	6	3200	170	4000	3900-4100	/
SE236S36	6	3200	170	3600	3400-3650	/
SE266E40	6	3200	190	4000	3850-4050	/
SE266S36	6	3200	190	3600	3300-3650	/
SE286E40	6	3200	205	4000	3900-4150	/
SE306J38	6	3200	215	3800	3500-3850	/

SE 6-cylinder engine models					
engine type	dry weight (kg)	Fuel cons @ rated power (kg/h)	MAP [mbar]	compression ratio	max. exhaust backpressure (mbar)
SE126E25	340	20,1	2130	$\epsilon = 17,0$	150
SE156E26	340	25,4	2200	$\epsilon = 17,0$	150
SE156E32	340	25,8	2280	$\epsilon = 17,0$	150
SE156E34	340	25,1	2240	$\epsilon = 17,0$	150
SE196E35	340	33,7	2280	$\epsilon = 17,0$	150
SE236E40	340	42,5	2790	$\epsilon = 17,0$	150
SE236S36	340	40,9	2560	$\epsilon = 17,0$	150
SE266E40	340	47,3	2840	$\epsilon = 17,0$	150
SE266S36	340	46,1	2740	$\epsilon = 17,0$	150
SE286E40	340	51	2990	$\epsilon = 17,0$	150
SE306J38	340	52,2	3060	$\epsilon = 17,0$	150

**SE 6-cylinder engine models**

engine type	backpressure tolerance (mbar)	max. engine cooling water outlet temp (°C)	max. engine coolant outlet temperature (°C)	Oil filling quantity [lt.]	Coolant water quantity [lt.]
SE126E25	+0/- 50	81	105	17,0	15,5
SE156E26	+0/- 50	83	105	17,0	15,5
SE156E32	+0/- 50	83	105	17,0	15,5
SE156E34	+0/- 50		105		
SE196E35	+0/- 50	83	105	17,0	15,5
SE236E40	+0/- 50	85	105	17,0	15,5
SE236S36	+0/- 50	86	105	17,0	15,5
SE266E40	+0/- 50	86	105	17,0	15,5
SE266S36	+0/- 50	86	105	17,0	15,5
SE286E40	+0/- 50	86	105	17,0	15,5
SE306J38	+0/- 50	87	105	17,0	15,5

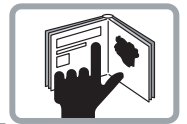

## Product References, Illustrations and Specifications

When reference is made in this manual to a brand name, number, product or specific tool, an equivalent product may be used in place of the product referred to unless specifically stated otherwise. Equivalent products which are used must meet all current local regulations and standards to avoid hazards.

Some countries may apply additional internal regulation. Please follow their advices appropriately, example:

Austria:	Bundesamt für Schifffahrt
Sweden:	Navigation Office
Finland:	Navigation Office
Norway:	DNV = Det Norske Veritas
USA:	USCG = United States Coast Guard
USA:	ABYC = American Boat Yacht Council
USA:	NMMA = National Marine Manufacturers Association
England:	LR = Lloyds Register of Shipping
France:	BV = Bureau Veritas
Germany:	GL = GERMANISCHER Lloyd
Italy:	RINA = Registro Italiano Navale

All information, illustrations and specifications contained in this manual are based on the latest product information available at the time of printing. **Steyr Motors Betriebs GmbH reserves the right to make changes at any time, without notice, to specifications and models and also to discontinue models, as well as the right to change specifications or parts at any time without incurring any obligation to equip same on models manufactured prior to date of such change.**

Continual accuracy of this manual cannot be guaranteed.

All illustrations used in this manual may not depict actual models or equipment and are intended as representative views for reference only.

## Insurance

Insurance on your **Steyr Motors Marine Engine** and boat should be obtained as soon as practical for protection against loss by fire, theft, etc. Consult your local insurance agent.

## Stolen Unit

The model and serial numbers on your engine are important for you. As to the location of these important numbers, refer to **Model and Serial Numbers** in the section Technical Data.

Record each of these numbers in the spaces provided at the end of this manual and on a separate sheet. Store the separate sheet in a safe place other than your boat.

In case of theft, report the model and serial numbers to your local authorities and your insurance agent.



## Warranty Declaration, Emission Related Warranty

The current version of the Steyr Motors warranty declaration and the emission-related warranty can be found under the following link on the homepage of Steyr Motors Betriebs GmbH: <http://www.steyr-motors.com/>.

## Warranty Registration Approval

When you purchase your boat, your dealer was obliged to issue a Warranty Registration Approval for your **Steyr Motors Marine Engine**.

This Warranty Registration Approval gives proof and is to be submitted in case of warranty claims. Your Steyr Motors Marine dealer is also obliged to complete the Warranty Registration Approval. Required tests and measurements are to be carried out from your Steyr Motors Marine dealer and sent to Steyr Motors Betriebs GmbH for approval of warranty registration.

## Dealer Service - Maintenance





**NOTE:** Please do not forget to have confirmed in your manual that the installation and maintenance have been carried out in accordance with the guidelines.

This is also an opportunity to clarify with your Steyr Motors marine dealer possible questions arisen during the first running hours on your boat, and to establish a service- and maintenance routine.

Services will be performed by **Steyr Motors Marine Dealers** at local rates.

Costs for service material to be paid by the owner.

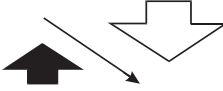
## Illustration Symbols

	Refer to the photograph or drawing described in that paragraph.
	Refer to specific items or features described in the text and illustrated on the photograph.
	Refer to the general subject of the text.
	Refer to an item or feature not clearly visible on the photograph.

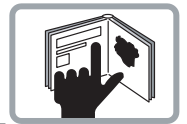

## Repair Service

All repair works on your Steyr Motors marine engine should be carried out by a licensed Steyr Motors Marine Dealer with his professional knowledge, trained staff and special-purpose tools to solve all occurring problems. Preferably, all work on your Steyr Motors marine engine should be carried out by the Steyr Motors Marine Dealer that sold the equipment to you - he knows you and the equipment.

If problems occur during a trip, bring your engine to the next Steyr Motors Marine Dealer. Information on Dealers and Distributors can be found at the end of this manual.

## Replacement Parts

Your Steyr Motors Marine Engine was designed to operate in a marine environment use Steyr Motors original replacement parts.

## Before Casting Off

Check the weather report, wind and water conditions. Tell someone where you are going to and when you expect to arrive or return.

### Recommended Minimum On-Board Tools

Screwdriver Set	lubrication oil spray
Metric Socket Set	12-volt pilot lamp
Metric Allen Key Set	flashlight
Metric Spanner Set	insulating tape
long nose pliers	sharp knife

### Recommended Minimum On-Board Spare Parts

propeller and small parts for propeller mounting	fuses
fuel filter ( pre- & finefilter)	bulbs
impeller for raw water pump	sealing compound

These lists represent a suggested **MINIMUM**, and are not intended to cover all boats or possible boating conditions.



## Engine Submersion

Remove engine from water as quickly as possible and contact your local Steyr Motors Marine dealer for service.

It is imperative that your dealer removes all water from the engine and immediately relubricates all internal parts. Electrical devices must be replaced. Delay in completing these actions may allow extensive engine damage.

Frequently check engine compartment for excessive water accumulation; water depth in bilge should be kept well below flywheel housing. Engine compartment must enable proper venting to avoid condensation to build up on inner surfaces.

## Bottom Painting

If your boat is in water where marine growth is a problem, the use of an antifouling paint will reduce the growth rate.

\* Tin base antifouling paint (TBTA or TBTF) is recommended where its use is permitted.

\* Copper base antifouling paint may be used, but will require more frequent inspection and replacement of sacrificial anodes. **DO NOT PAINT** any part of the drive unit with copper base antifouling paint.

**NOTE:** Painting the drive unit with copper base paint will accelerate galvanic corrosion.

\* Vinyl-butyl base antifouling paint is a recommended alternative.

\* **DO NOT USE** any graphite base antifouling paint.

**NOTE:** Never paint anti-corrosion anodes, or their effectiveness will be lost. See your Steyr Motors Marine contract partner for an antifouling paint that is suitable for your area.

## Boat Bottom

The condition of the boat bottom can affect your boat's performance. Marine growth, present in fresh water as well as salt water, will reduce boat speed. A boat bottom with evidence of marine growth causes a reduction in top speed of 20 percent or more. Periodically clean the bottom of your boat following the manufacturer's recommendations.



## Boating Responsibilities

As a boat owner, you have certain responsibilities to others. Be sure that all operators read this manual.

You are legally responsible for all occupants of your boat. Instruct at least one of your passengers in the basic fundamentals of handling your boat in case of an emergency. Show all hands the location of emergency equipment and how to use it. You are required by law to have one locally approved life jacket for each person aboard, plus one approved throwable device for man overboard protection.

Learn the waterway rules of the location in which you are going to operate your boat. Navigable waterways are controlled by Federal regulations while inland lakes are controlled by local jurisdictions. Obey these regulations to protect yourself, your passengers and fellow boating enthusiasts.

Thoroughly familiarize yourself with weather station warning system signals and waterway traffic signs.

Contact your local Coast Guard station and take advantage of their seasonal boat inspections and training courses.

## Safety

This manual contains certain information related to the personal safety of you the operator, your passengers and bystanders.



The Safety symbol  **ATTENTION:** appears next to important information to prevent you and others from being hurt.

The symbol **NOTE:** appears next to important information to keep machinery from being damaged.

Observe all notes and safety warnings contained in this manual.

## WARNING

























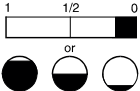





### CALIFORNIA: PROPOSITION 65 WARNING

Diesel engine exhaust and some of its constituents are known to the state of California to cause cancer, birth defects, and other reproductive harm.



## Symbols

Certain symbols or combinations of symbols may appear on your **Steyr Motors Marine Engine** or on its accessories. It is very important that you understand their meaning or purpose. If any symbol is not clearly understood, see your DEALER.

<b>"Safety Warning" Symbols</b>			
	Means risk of <b>SERIOUS</b> injury is present. Follow instructions in the Operation, Maintenance & Warranty Manual before using motor or accessory.		Means place shift control in <b>NEUTRAL</b> before starting motor. Follow instructions in Operation, Maintenance & Warranty Manual before starting motor.
	Indicates that contents are under pressure.		Identifies poisonous material.
			Indicates a potential fire hazard.
			Indicates that <b>ELECTRICITY</b> of more than 50 volts is present.
<b>"Position Indicator" Symbols</b>			
	Indicates upward movement. Example: While boat is at planing speed, activating trim switch to raise the bow of the boat.		Indicates downward movement. Example: While boat is at planing speed, activating trim switch to lower the bow of the boat.
			Indicates gear shift control positions: <b>FORWARD</b> , <b>NEUTRAL</b> and <b>REVERSE</b>
<b>"Condition" Symbols</b>			
	Identifies the meter which indicates accumulative running hours of engine.		Identifies the meter which indicates battery voltage or amperage.
	Identifies battery or a meter which indicates status of battery-generator charging system.		Identifies the amount of liquid in tank.
	Identifies the meter which indicates engine coolant temperature.		<b>FILTER</b> : Identifies a device which removes contaminants from engine's oil system.
			Identifies the meter which indicates engine coolant pressure.
			Identifies the meter which indicates the pressure of engine's lubricating system.
<b>"Functional Description" Symbols</b>			
	<b>FILTER</b> : Identifies a device which removes contaminants from fuel.		Identifies the <b>EMERGENCY IGNITION CUT-OFF SWITCH</b> . Emergency engine stop.
	Identifies the negative ground or negative voltage connection.		Identifies engine drain plugs and fittings.
	Identifies the <b>STOP SWITCH</b> . It may also identify <b>STOP</b> position of the throttle control.		Identifies the operating device for starting the motor.
<b>"Instructional" Symbols</b>			
	Indicates <b>FUEL</b> is to be used or <b>FUEL</b> is present.		Means read your Operation, Maintenance & Warranty Manual before operating the product. It contains information or instructions vital for operation of product.
	Indicates <b>OIL</b> is to be used or <b>OIL</b> is present.		<b>ENGINE OIL FILL</b> : Location for introduction of oil into the engine.
			Indicates areas to be lubricated.
			Indicates lubricating oil used in transmissions.



This page is intentionally blank

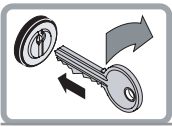

## START-UP AND FUNCTIONS

Before Starting.....	24
Starting the Engine (key switch version) .....	25
Stopping the Engine .....	25
Starting the Engine (push button version) .....	26
Stopping the Engine (push button version) .....	26
Run In Procedure After Major Overhaul .....	27
Definitions.....	27
Procedure, Work steps .....	27
Engine Break-In procedure.....	28
First Ten Hours .....	28
Final Ten Hours of Break-in .....	28
Operation after Break-In .....	29
Shifting.....	30
Remote Control Operating Instructions .....	31
How to Shift and Control Speed .....	32
Fuel Economy.....	32
Gear Box - Information .....	32
Fixed Speed Switch.....	32
Instrument panel (key switch version) .....	33
Instrument panel, standard.....	33
Instrument indication during normal operation .....	34
Instrument panel (push button version) .....	35
Instrument indication during normal operation (push button version) .....	36
Emergency cut off switch (Lanyard) .....	37
Warning lights and audible alarm .....	38

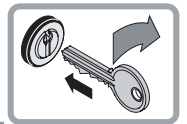

**START-UP AND FUNCTIONS**

Electronic Engine Control Unit (ECU).....39

Diagnostic system .....40

Twin Installations .....41

Optional Propellers .....41

Propellers .....41

Propeller Torque .....42

Propeller Care .....42

Water Jet .....42

Operating Procedure for Freezing Temperatures .....42

Salt Water Operation .....42

High Altitude Operation.....42

Fuel Pump .....43

Fuel System Checks.....43

Fuel Contamination .....43

External mounted fuel system version.....44

Cooling System .....46

Electrical Equipment.....48

Alternator .....48

Battery .....48

Circuit Breakers & Fuses 4 Cylinder Marine Engine .....49

Circuit Breakers & Fuses 6 Cylinder SE Marine Engine.....49

Inversion Switch (optional) .....50

Interrupt crankshaft housing ventilation (optional).....50

Instrument Panel .....50

Dry operation .....50

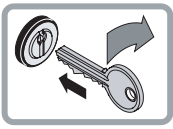

## Before Starting

Familiarize yourself with the handling of the boat, in particular how to use transmission, and then proceed as follows:

1. Check the bilge for excessive water accumulation. Always keep the bilge clean and dry. Never allow the water level in the engine compartment to exceed the bottom of the oil pan. If water accumulation is unavoidable, install a bilge pump with an automatic control switch.

**NOTE:** The water level in the boat's engine compartment will increase when the boat is operated at a high incline before planing speed is reached. Excessive water accumulation in the engine compartment/bilge may cause engine failures.

2. Open the raw water intake valve.

**NOTE:** Operate the engine only while the raw water supply is assured or the cooling system is equipped with a flushing device. The raw water pump will be damaged and/or the engine will overheat if operated without cooling water.

3. Open the fuel stop valve.

**NOTE:** Only start the engine when a bubble-free fuel supply is guaranteed. Prior to first start-up of the engine (after installation, after storage etc.), purge the fuel system by "ignition ON" for 6 x 10 sec.

If the suction height of the fuel-pump is more than 0.5 m, the fuel supply line must be filled before first start-up of the engine.

4. Check the operating levels of:

- \* coolant
- \* oil
- \* hydraulic oil
- \* transmission oil
- \* fuel

5. Control of electric system:

- \* Charge and charge state of battery

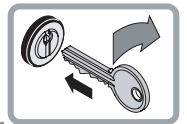

## Starting the Engine (key switch version)

Starting procedure for the **Steyr Motors marine engine** is the same for both cold and warm engines. The engine control unit **automatically regulates the fuel supply and the preheating period**, for any given temperature. Therefore, the throttle lever should remain in neutral position.

1. To start the engine, move throttle lever into idle position and gear into neutral position.
2. Turn ignition key into position ignition "ON". An audible alarm will sound and the warning lights are illuminated (temporary), indicating the correct function of the audible and visual warning systems.

**NOTE:** In case of a low temperature start wait until the combined oil pressure/glow plug pre-heating indication light is turned off, before you continue with the start procedure.

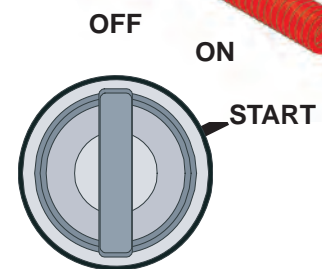

3. Turn ignition key into position "START" and hold in this position until "starting" of engine, but under no circumstances hold in this position for more than ten seconds.  
If engine does not start, release **ignition key**, **wait 30 seconds** to cool down starter motor, repeat **starting procedure**.
4. As soon as engine starts, release ignition key. The audible alarm will stop when normal oil pressure has been reached.

**CAUTION:** If engine fails to start within one minute and/or repeated attempts, contact your **Steyr Motors Marine dealer**.  
Never turn ignition key to position "START" when engine is running.



## Stopping the Engine

1. Move throttle lever into idle position and gear in neutral position.
2. Cool down the engine.
3. Turn ignition key to "OFF" position.

**CAUTION:** Do not stop engine at speeds above idle or "accelerate" engine while turning off ignition. This may result in engine failures.



Download Instrument Panel Documentation from [www.steyr-motors.com](http://www.steyr-motors.com):  
Download → Marine → SE Series General → Instrument Panel

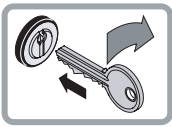

## Starting the Engine (push button version)

Starting procedure for the **Steyr Motors marine engine** is the same for cold or warm operating condition. The engine control unit **automatically regulates the fuel supply and the preheating period**, for any given temperature. Therefore, the throttle lever should remain in neutral position.

1. To start the engine, move throttle lever into idle position and gear into neutral position.
2. Press the **push button for ignition** (fig. F; red) (push button lock in place); An audible alarm will sound and the warning lights are illuminated (temporary), indicating the correct function of the audible and visual warning system.

**NOTE:** In case of a low temperature start, wait until the combined oil pressure/glow plug pre-heating indication light is turned off, then continue with the start procedure.

3. Press the **button START** (fig. G; green) and hold in this position until **“starting”** of engine, but under no circumstances hold in this position for more than ten seconds.  
If engine does not start, release **ignition key**, **wait 30 seconds** to cool down starter motor, repeat **starting procedure**.
4. As soon as engine starts, release start button. The audible alarm will stop when normal oil pressure has been reached.

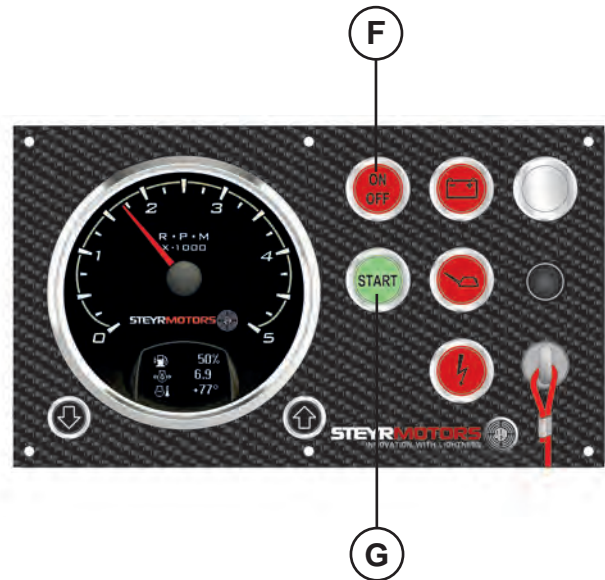

**CAUTION:**  If engine fails to start within one minute and/or repeated attempts, contact your **Steyr Motors** marine dealer.  
Never push start button when engine is running.

## Stopping the Engine (push button version)

1. Move throttle lever into idle position and gear in neutral position.
2. Cool down the engine.
3. Press push **button ignition ON/OFF** (fig. F) to disengage from locking position and to shut OFF the engine.

**CAUTION:**  Do not stop engine at speeds above idle or “accelerate” engine while turning off engine. This may result in engine failures.

Download Instrument Panel Documentation from [www.steyr-motors.com](http://www.steyr-motors.com):  
Download → Marine → SE Series General → Instrument Panel

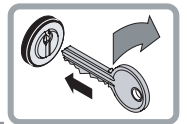

## Run In Procedure After Major Overhaul

The following run in procedure must be used on **Steyr Motors** engines following a major overhaul, where a major overhaul is defined as a replacement of any or all of the following:

Crankshaft, Piston(s), Con rod(s), Monoblock

### Definitions

- \* Rated speed                      Engine speed with maximum power
- \* Half engine speed                Half of rated speed

### Procedure, Work steps

#### Preparation

- \* Engine filled with oil and coolant to max. levels
- \* Steyr High Performance Diesel-Engine Oil 10W-40
- \* Steyr Motors engine coolant (if not available use GlycoShell - 50/50 % water/coolant)
- \* **Steyr Motors** engine diagnostic tool connected to the ECU

#### Test method

- \* Remove the expansion tank pressure cap for degassing the system
- \* Start the engine
- \* Run at idle speed for 20 min
- \* Stop the engine
- \* Check coolant and oil level, top up to max. level if necessary
- \* Close the expansion tank with the pressure cap
- \* Start the engine
- \* Warm up the engine (~ 15 mins.)
- \* Run the boat minimum for 4 hrs at no more than half engine speed
- \* Check oil level, top up to max level
- \* Check the error list in the ECU using the diagnostic programme, if no errors continue run in. If errors occurred, contact **Steyr Motors** authorized Service-Partner for further decisions
- \* Warm up the engine (~ 15 mins.)
- \* Run the boat minimum for 2 hrs at no more than 75 % engine speed
- \* Check the service code list in the ECU using the diagnostic program, if no errors continue run in. If errors occurred, contact **Steyr Motors** authorized Service-Partner for further decisions
- \* Warm up the engine (~ 15 mins.)
- \* Start the **Steyr Motors** diagnostic tool data logger
- \* Run the boat minimum for 20 mins. at full rated speed
- \* Stop diagnostic tool data logger and save the file (filename: engine number and date e.g. 68225765\_20080910.dat)
- \* Check the service code list in the ECU. If errors occurred, contact **Steyr Motors** authorized Service-Partner for further decisions
- \* Send the data Log file to **Steyr Motors** authorized Service-Partner
- \* Check coolant and oil level at cold engine, top up to max. level if necessary
- \* Continue using the engine acc. to **Steyr Motors** Operator Manual

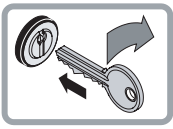

## Engine Break-In procedure

All **Steyr Motors marine engines** have been run for a short period as a final test at the factory. You must follow the Engine Break-In instructions during the first 20 running hours to ensure maximum performance and longest engine life.

**NOTE:** Non-observance of break-in instructions may cause severe engine failure.

### First Ten Hours

**Maximum Engine Speed: 75 % of rated speed**

**Maximum Throttle Position: 75 %**

For the first five to ten minutes of operation, run the engine at low speed (below 1500 RPM). For the remaining first ten hours of operation, accelerate to bring boat onto plane quickly. After reaching planing reduce throttle to remain at minimum planing. For displacement or semi displacement boats the throttle position of 75 % must not be transcended. Occasionally reduce throttle to idle speed for cooling down.

**CAUTION:**



Warning indication engine over load during break - in via ECU (Engine Control Unit) The ECU monitors, during the first two hours of engine operation, the load on the engine. If the engine is overloaded (during the first 2 hours of running) the "Check Engine Light" will automatically illuminate. If the warning light illuminates (CEL light - ON), the throttle position must be reduced until this signals are extinguish.

### Final Ten Hours of Break-in

**Maximum Short Term Speed: 100 % of rated speed**

**Maximum Short Term Throttle Position: 100 %**

During the final ten hours of break-in, the engine may run at full speed **for max. 2 minutes**. The remaining hours should be operated up to 75 % throttle position. For displacement or semi displacement boats the throttle position of 75 % must not be transcended Occasionally reduce the engine speed to cool is down.

**NOTE:** During the break-in period, the engine must not be operated at high rpm for longer periods.

During break-in period, be particularly observant of the following:

- A. Check motor oil level daily. Always maintain oil level in the desired range between the "MIN" and "MAX" marks on dipstick. When refilling motor oil, refer to information "Engine Lubrication - Motor Oil".
- B. Check oil pressure control lamp. If the lamp lights up as soon as the boat changes its position (while turning, straightening up the boat or planing), check the oil level in the engine housing by means of dipstick. If necessary, add oil (DO NOT OVERFILL). In case that the oil pressure control lamp is still illuminated with correct oil level, have the engine checked by your **Steyr Motors** marine dealer as to malfunction of signal or oil pump.

**NOTE:** During normal operation of engine, oil pressure will rise as RPM increases and fall as RPM decreases. In general, oil pressure will be higher with cold engine oil and specific RPM than with hot motor oil.

- C. Check engine temperature indication. Normal operation between 75 °C - 95 °C (part heat up to full load, at idle speed the engine temperature will be between 68 °C and 80 °C depending on ambient temp. and raw water temperature). In case of audible alarm, check coolant level in expansion tank (only with cold engine).
- D. Deviations from normal operating conditions will be indicated by warning lights and audible alarm. As to exact meanings see section Error Indication on Instrument Panel.

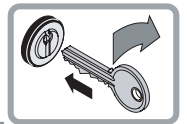

**CAUTION:** In case of non-observance of break-in instructions, warranty may expire.



Engine to be filled with recommended oil quality only. See chapter “Engine Lubrication”.

### Operation after Break-In

The engines specified in this manual are intended to be operated at different speeds and loads, but not allowing full-load of the engine for more than one hour per 12 running hours. Economic driving may be achieved at the following speeds:

#### 4 Cylinder MO Marine Engines

MO54NA33	<b>3000 rpm</b>
MO84K32	<b>3000 rpm</b>
MO94K33	<b>3000 rpm</b>
MO114K33	<b>3000 rpm</b>
MO144M38	<b>3200 rpm</b>
MO164M40	<b>3400 rpm</b>
MO174V40	<b>3400 rpm</b>

#### 4 Cylinder SE Marine Engines

SE144E38	<b>3400 rpm</b>
SE164E40	<b>3600 rpm</b>

#### 6 Cylinder SE Marine Engines

SE126E25	<b>2300 rpm</b>
SE156E26	<b>2400 rpm</b>
SE156E32	<b>3000 rpm</b>
SE156E34	<b>3200 rpm</b>
SE196E35	<b>3200 rpm</b>
SE236E40	<b>3800 rpm</b>
SE236S36	<b>3400 rpm</b>
SE266E40	<b>3800 rpm</b>
SE266S36	<b>3400 rpm</b>
SE286E40	<b>3800 rpm</b>
SE306J38	<b>3600 rpm</b>

Which will prolong engine life and reduce sound emissions.

When starting a cold engine, always allow the engine to warm up slowly. Never run the engine at full speed until operating temperature is reached. During the first 50 running hours, check the oil level frequently.

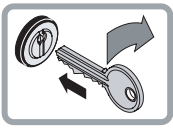

## Shifting

### Example: single lever shift control system

1. If the gear shift mechanism is disengaged, move the control lever to neutral position. The shift mechanism will automatically engage.
2. To go FORWARD - press the neutral lock button if fitted, and move the control lever forward. Throttle movement will begin after forward gear engagement.
3. To go in REVERSE - press the neutral lock button if fitted, and move the control lever backwards. Throttle movement will begin after reverse gear engagement.
4. To go from FORWARD to REVERSE, or REVERSE to FORWARD, always pause at NEUTRAL and allow engine speed to return to idle and vessel speed below 1 kn.
5. After shifting is completed, continue to move the control lever slowly in the desired direction to increase speed.

**NOTE:** A sudden increase in shifting torque on the remote control lever indicates a possible problem in the shifting system. If so, see your Steyr Motors dealer as soon as possible for proper diagnosis and necessary service adjustment. Continued operation under this condition could result in damage to the shifting mechanism.

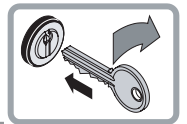

## Remote Control Operating Instructions

1 Your boat may be equipped with one of the following remote controls:

- \* Single lever control
- \* Dual lever control for twin engines

**NOTE:** If other than **Steyr Motors Betriebs GmbH** matched remote controls are used, follow the manufacturer's recommendation.

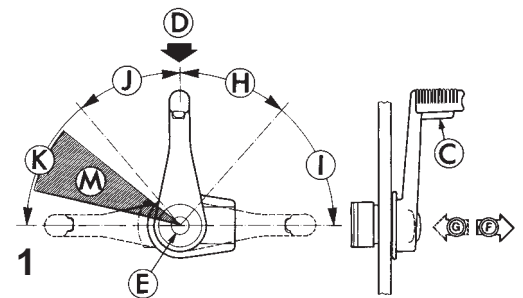

Remote controls have the following important features:

- \* A single lever which allows to select forward or reverse gear, regulate engine speed, and ensure shifting is done at low engine speed.
- \* A start-in-neutral-only feature which will protect you from starting your **Steyr Motors Marine Engine** with engaged gears.

The side mount control has a neutral lock button **(C)** located in the control lever which must be pressed to permit shifting from neutral to forward or reverse. The top mount controls do not have a neutral lock, but there is a neutral ratchet position.

### Side Mount Control

- \* To disengage shift mechanism:
    1. Place control lever into neutral position **(D)**
    2. Press both neutral lock button **(C)** and shift disengage button **(E)**
    3. Move control lever forward to increase throttle
- (F)** Shift mechanism engaged  
**(G)** Shift mechanism disengaged

The neutral lock and shift mechanism will automatically engage when the control lever is returned to neutral position.

### Top Mount Control

- \* To disengage shift mechanism:
  1. Grasp the control lever hub and pull straight in for approximately ¼ " (6 mm).
  2. Move control lever forward to increase throttle.

The shift mechanism will automatically engage when control lever is returned to neutral.

Your boat may be equipped with remote controls other than those described above. When not using **Steyr Motors** marine engine matched controls, ask your DEALER for operating instructions for the remote control used in your boat since operation and function may differ from **Steyr Motors** marine engine matched remote controls.

**CAUTION:** Your boat should be equipped by manufacturer with a remote control with protection against starting in gear. Only use a remote control with start-in-neutral-only feature. This feature can prevent injury resulting from unexpected turning of the propeller and sudden movement of the boat.



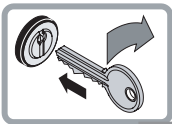

## How to Shift and Control Speed

**NOTE:** Do not shift into FORWARD or REVERSE unless engine is running. Damage to the shift mechanism could result from trying to shift without the engine running.

- 2 Move the control lever to neutral position **(D)**. The shift mechanism will automatically engage. Press neutral lock button **(C)** on some single side mount control and move the control lever to shift into forward or reverse. The throttle will begin to advance after gear engagement. Continue to move the control lever slowly in the desired direction to increase speed.

- (H)** Reverse Shift Range
- (I)** Reverse Throttle Range
- (D)** Neutral position
- (J)** Forward Throttle Range
- (K)** Forward Shift Range

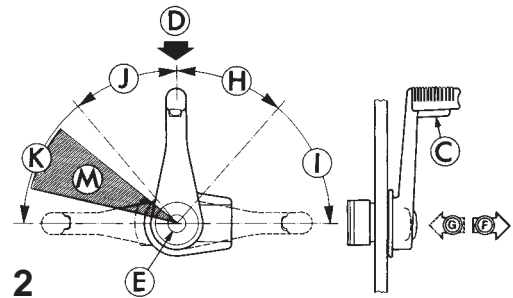

## Fuel Economy

Using the fuel economy throttle range **(M)** can save fuel depending on boat load and hull design. When the boat reaches top speed, reduce engine speed slightly. Make sure the boat maintains to plane when reducing engine speed. Continue to reduce engine speed slightly while maintaining to plane. Do not allow boat to fall off plane. This will give a comfortable ride and help to save fuel at the same time.

## Gear Box - Information

**NOTE:** You are requested to follow the instructions and recommendations provided by the marine gear box manufacturer.

## Fixed Speed Switch

**NOTE:** Shift into gear must only be done with idling speed!

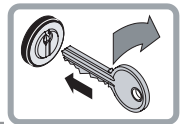

**Instrument Panel (Key Switch Version)**

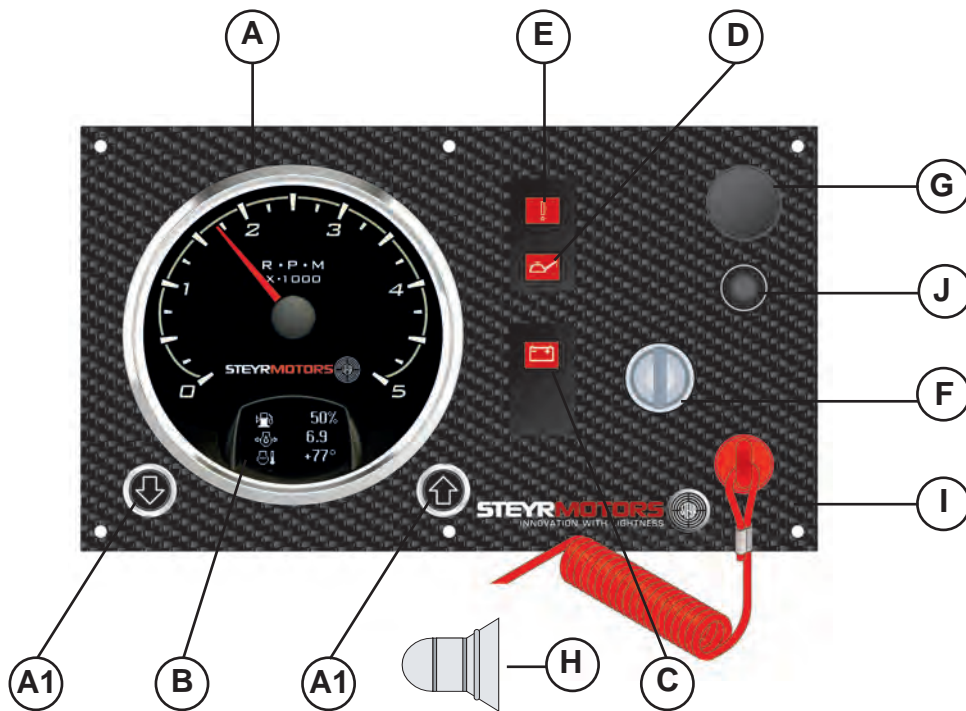

**Instrument Panel, Standard**

- |  |  |
|--|--|
| <b>A</b> tachometer  | <b>F</b> ignition key  |
| <b>A1</b> function buttons   | <b>G</b> blind plug - installation option for key switch constant revolution |
| <b>B</b> engine parameter display  | <b>H</b> audible warning device (installed on rear side of panel)            |
| <b>C</b> warning light - battery charge  | <b>I</b> emergency cut off switch (lanyard)                                  |
| <b>D</b> combined light preheating control & warning light - engine oil pressure | <b>J</b> circuit breaker (10 amp)  |
| <b>E</b> warning light - check engine  |  |

If you should need additional instruments or accessories, please contact your Steyr Motors Marine dealer.

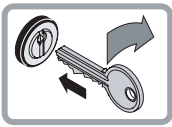

## Instrument Indication During Normal Operation

### 1. ignition ON (... before starting)

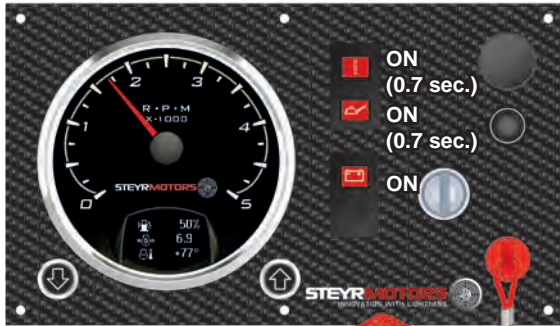

**System check** - see light indication

**NOTE:**

At low temperature condition (cold weather) the combined light for glow plug preheating & engine oil pressure will not extinguish after 0.7 sec. (glow plug preheating phase).

In this case start engine immediately after the light extinguishes.

### 2. ignition ON (... before starting)



**Indication active error**

### 3. engine running (after start)



**Normal condition**

**NOTE:**

For further information see:

“Table - Error indication on Instrument Panel”

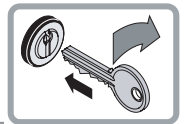

**Instrument Panel (Push Button Version)**

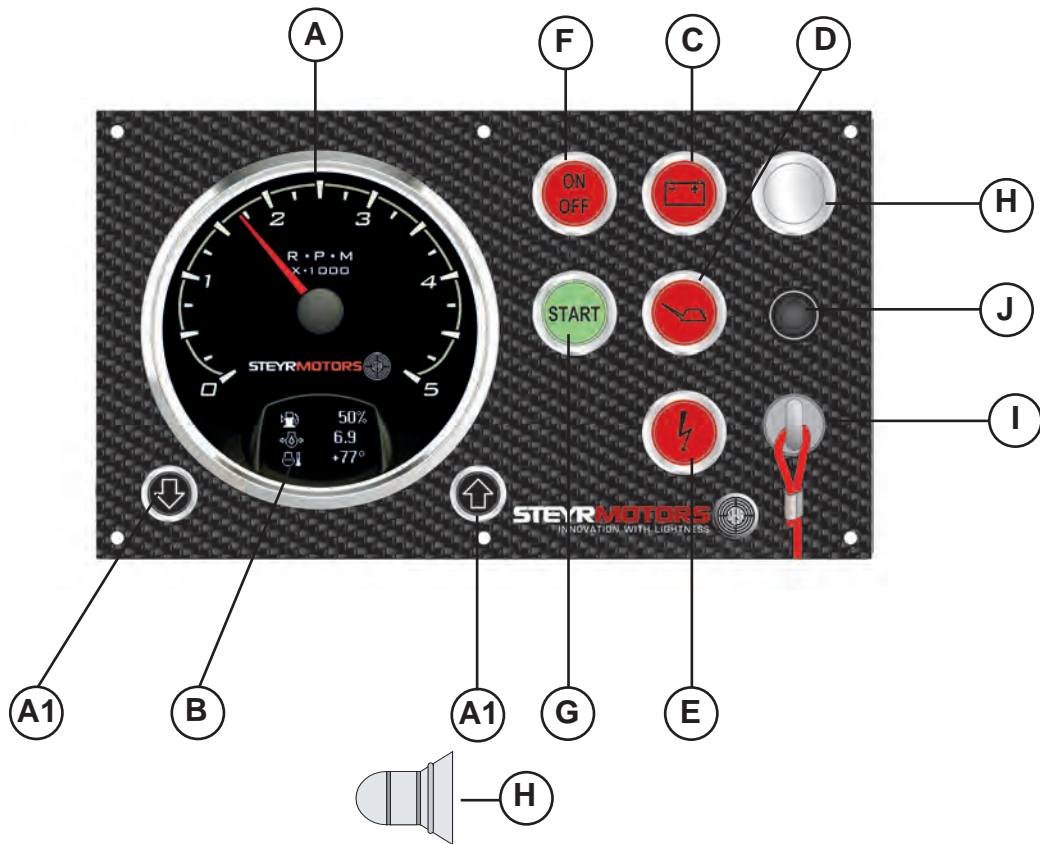

- |   |  |
|---|--|
| <b>A</b> tachometer   | <b>F</b> push button - ignition ON/OFF (red)                         |
| <b>A1</b> function buttons  | <b>G</b> push button - START (green)                                 |
| <b>B</b> engine parameter display   | <b>H</b> audible warning device<br>(installed on rear side of panel) |
| <b>C</b> warning light - battery charge   | <b>I</b> emergency cut off switch (lanyard)                          |
| <b>D</b> combined light preheating control &<br>warning light - engine oil pressure | <b>J</b> circuit breaker (10 amp)                                    |
| <b>E</b> warning light - check engine   |  |

**NOTE:** Instrument gauges are automatically illuminated if ignition is turned ON.

**NOTE:** In the case of inversion the engine will be automatically shut off, in order to allow normal operation later. The ignition push button (F) must be switched OFF and ON again, then the engine can be restarted via the push button START (G).

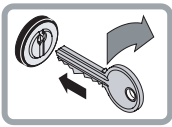

## Instrument Indication During Normal Operation (Push Button Version)

### 1. ignition ON (... before starting)



**System check** - see light indication

**NOTE:**

At low temperature condition (cold weather) the combined light for glow plug preheating & warning light engine oil pressure will not extinguish after 0.7 sec. (glow plug preheating phase).

In this case start engine immediately after the light extinguishes.

### 2. ignition ON (... before starting)



**Indication active error**

### 3. engine running (after start)



**Normal condition**

**NOTE:**

For further information see:

**“Table - Error indication on Instrument Panel”**

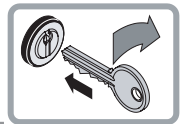

## Emergency Cut off Switch (Lanyard)

An emergency cut off switch is a feature on the instrument panel. Use of this switch is highly recommended. To properly use this feature, attach the lanyard securely to your clothing. Do not attach the lanyard to clothing that will tear away before the lanyard is pulled from switch to stop the engine. Using this switch is simple and should not interfere with normal operation of the boat. Care must be taken to avoid accidental pulling of lanyard during normal operation. Unexpected loss of forward motion will occur. This could allow occupants to be thrown forward. In case the emergency cut off switch had been activated (lanyard pulled) the engine can be restarted by a person if; the pull knob (fig. pos. 1) of the emergency switch is being pulled and held in this position. While holding the pull knob proceed with the normal start procedure and start engine. The engine will immediately stop if the pull knob is released under this circumstances.



**CAUTION:**



The emergency cut off switch can only be effective when in good working condition.

Observe the following:

- \* Lanyard must always be free of entanglements that could hinder its operation.
- \* Once a month, check switch for proper operation. With engine running, pull lanyard. If engine does not stop, see your Steyr Motors dealer for replacement of switch.

Do not use the Emergency cut off switch as a "Stop"-switch. This will reduce the life time of the Emergency cut off switch!

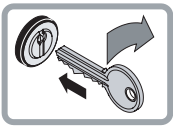

## Warning Lights and Audible Alarm

Your boat with the **Steyr Motors marine engine** is equipped with three warning lights and one audible alarm (mounted behind the instrument panel) to indicate the following operation condition or system deficiencies (The ECU will also reduce the engine power in case an important operating parameter limit has been exceeded).

- \* Indication pre-warming phase (combined indication through oil pressure light. Becomes affective if ambient engine coolant temperature is below 20 °C / 68 °F)
- \* Break - In; over load warning
- \* Engine oil pressure too low
- \* High coolant temperature
- \* Sensors or sensor circuit defect

After ignition is turned "ON" the indication/warning lights are illuminated and the warning horn will sound for less then a second (0.7 sec.) this serves as a functional check for the optical/audible warning system.

The indication light and the warning horn remain switched on for 5 sec. after ignition "ON" if a sensor or sensor circuit defect have been detected and stored in the Engine Control Unit (ECU) (see section Instrument Panel).

Please contact your nearest Steyr Motors marine dealer to get professional assistance to verify the deficiency and to correct any possible failure.

If the engine oil pressure is too low, the warning light "engine oil pressure" lights and the audible alarm sounds. The engine power will be limited. In this case proceed as follows:

- \* Check engine oil level, respectively add engine oil if necessary (refer to chapter Fuel and Lubricants)
- \* Restart engine and watch the oil pressure light. The warning light has to extinguish within 3 or 4 seconds after the start. If this does not happen **the engine must be stopped immediately** (Ignition "OFF").

In case of an overheating of the exhaust gas cooling system, the warning light "engine control" flashes and the audible alarm sounds (2 times per second); the engine power is reduced. In this case, proceed as follows:

- \* IMMEDIATELY reduce the engine to idle speed.
- \* Check an clean the raw water filter.
- \* Check the coolant temperature gauge for overheating of engine coolant. If the coolant temperature gauge indicates overheating of engine coolant, switch for a short time to REVERSE to remove a possible clogging of the raw water inlet through large plastic parts etc., and then to FORWARD. Let the engine run at idle speed for some minutes. If the temperature gauge still indicates an overheating of the engine, the engine is to be stopped. Restart the engine only after having found and eliminated the cause for alarm. See "**loss of power**" in **Trouble Shooting Chart, Technical Data and in section Maintenance**. Check coolant level and if necessary, refill coolant until an adequate coolant level is achieved. If the cause for optical/audible alarm cannot be found, consult your Steyr Motors Marine dealer.

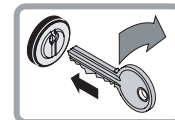

## Electronic Engine Control Unit (ECU)

The **Steyr Motors Marine engine** is equipped with an Electronic Engine Control Unit (ECU) that performs the following:

- \* controls engine functions to ensure maximum efficiency.
- \* self-diagnostic to protect the engine from damage if operating parameter are exceeded.
- \* stores diagnostic data of ECU server circuits for maintenance and service.
- \* stores abuse data

### Engine power is reduced if:

Operating Parameter	Effect noticed	Panel Indication	Additional Tool-Readings	Action or possible reason
High engine coolant temperature limit exceeded	Reduction of engine speed	Horn ON 2x p. sec. Gauge reading > 107 °C	Steyr Diag Power limitation	See table trouble shooting: Cooling system
Defect - engine coolant sensor or sensor connection	Reduction of engine speed	Horn ON 2x p. sec.	Steyr Diag Service code	Sensor or connector failure; see service code table
Exhaust temperature limit exceeded	Reduction of engine speed	Horn and indication light "CEL" ON 2x p. sec.	Steyr Diag Power limitation	See table trouble shooting: Raw water cooling system
Defect - Exhaust temperature sensor or sensor connection	Reduction of engine speed	Horn and indication light "CEL" ON 2x p. sec.	Steyr Diag Service code	Sensor or connector failure; see service code table
Oil pressure below limit	Reduction of engine speed	Horn continuous and Oil indication light continuous switched ON	Steyr Diag Power limitation	See table trouble shooting: Engine oil system
Defect - Oil pressure sensor or sensor connection	Reduction of engine speed	Oil pressure indication light switched ON 1x p. sec.	Steyr Diag Service code	Sensor or connector failure; see service code table
Insufficient boost pressure or defective sensor	Reduction of engine speed		Steyr Diag Power limitation	See table trouble shooting: Air charge system
Engine speed sensor fault	Irregular engine speed or stalled engine	No RPM indication on tachometer	Steyr Diag Service code	See table trouble shooting: Speed sensor
Engine speed remains at idle	No increase of engine speed if throttle is moved to max.		Steyr Diag Service code	See table trouble shooting: Accelerator potentiometer failure
Governor position system	Irregular engine speed or stalled engine		Steyr Diag Service code	See table trouble shooting: Governing system

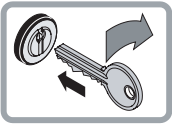

## Diagnostic System

The electronic engine control unit monitors the following engine parameters:  
oil pressure, boost pressure, coolant temperature, exhaust pipe temperature (hi-riser), sensor control rack, potentiometer accelerator, speed signal

The ECU carries out self-diagnostic and/or plausibility checks for all input values and sensor connections. In case of irregularities, there is an optical or audible warning signal (see Table - Error Indication on Instrument Panel).

Stored service codes can be selected and cleared after elimination of deficiency via SCC (Steyr Control Center). Please consult authorized **Steyr Motors** service partners to assist in fault finding procedure if necessary.

Malfunction during operation is ranked in three different categories intermittent failure, non essential failure and essential failure.

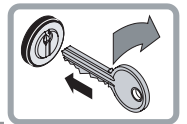

## Twin Installations

All **Steyr Motors marine engine** inboard models can also be set up for counter-rotation for twin installation. This is done by inverting direction of cable lines on shift lever in order to achieve a counter-rotation of propeller.

Counter-rotation is accomplished in the gearbox. The propeller, propeller shaft and output gear are the only parts that counter-rotate. The engine always has standard rotation.

- 4** It is customary to operate your propeller as shown on this illustration for twin installation. Some boat manufacturers may set up twin installations the opposite way. When propellers and/or cable lines are removed, care must be taken to attach them at the same position as before, and that the propellers are not exchanged.

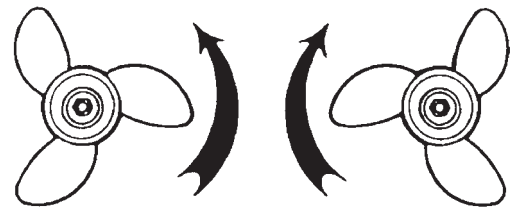

**4**

## Optional Propellers

Propellers are available in all regular sizes for both right- and left-hand rotation. Stainless steel has greater strength and durability than aluminium. This allows the stainless steel propeller blades to be thinner and still maintain more beam strength than aluminium propellers. The result is a more efficient propeller that gives better performance and more fuel economy.

## Propellers

- 5** Right-hand propellers rotate clockwise to propel a boat forward. Right-hand propellers are considered standard-rotation propellers. To identify a right-hand propeller, note the angle **(A)** of the blade as seen from port side.
- 6** Left-hand propellers rotate counter clockwise to propel a boat forward. Left-hand propellers are considered counter-rotation propellers. To identify a left-hand propeller, note the angle **(B)** of the blade as seen from port side.

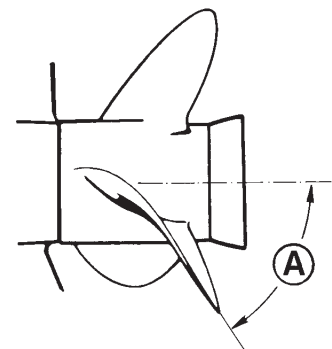

**5**

**NOTE:** Never interchange a right-hand propeller with a left-hand propeller. This would result in the boat being propelled in reverse when propulsion units are operated in forward gear, and forward when propulsion units are operated in reverse gear. To help you better understand and show the difference between left-hand and right-hand propellers, see figures.

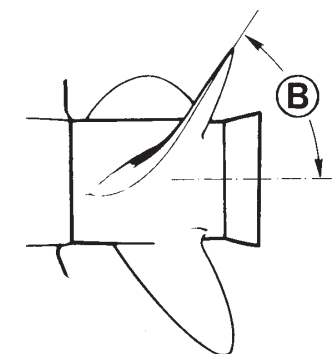

**6**

After having the propellers serviced, always shift into FORWARD or REVERSE at idle speed and determine whether the boat moves in the right direction. If the boat moves in the OPPOSITE direction, the propellers have not been installed properly.

**CAUTION:** Failure to perform above test could result in loss of control.



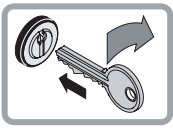

## Propeller Torque

The torque of the propeller creates forces that are transmitted to the boat. This can cause the boat to lean to one side (list).

The forces created by the counter-rotating propeller are opposite to the forces created by the standard rotating propeller. When the vertical drives are trimmed equal, these opposite forces balance each other.

## Propeller Care

A damaged or unbalanced propeller will cause excessive vibration and a loss of boat speed. Under these conditions, stop the engine and check the propeller for damage. If the propeller seems to be damaged, have it checked and repaired by your local **Steyr Motors** marine dealer. Always carry a spare propeller and replace the damaged propeller as soon as possible.

**NOTE:** Never run with a damaged propeller. Running with a damaged propeller can result in damage to drive components and engine.

## Water Jet

When using water jet drives, please contact your Steyr Motors Marine dealer. As to information on function and application, please refer to respective documents and documentation of the drive manufacturer.

## Operating Procedure for Freezing Temperatures

When freezing temperatures are forecast and the boat will be operated and left in the water, the propeller must remain in the tilted down (submerged) position at all times to prevent water in the vertical drive from freezing. Upon completion of engine operation, drain the engine as described in **Off-Season Storage Preparations**.

## Salt Water Operation

Fresh water to flush the raw water circuit is recommended after use in salt, polluted, or brackish water to prevent deposits from clogging and corroding the cooling passages. Contact your **Steyr Motors** Marine dealer to obtain an Engine Flushing Kit that allows flushing of the engine when in or out of the water.

**NOTE:** Use in salt or brackish water may require additional anti-corrosion protection.

**NOTE:** START and RUN Diesel-Engine while raw water circuit is flushed with fresh water!

## High Altitude Operation

Your **Steyr Motors** marine engine is specified to operate within an altitude from a sea level of 1000 meters without any performance loss. Operation in altitudes above 1000 meters are not recommended.

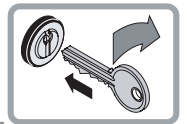

## Fuel Pump

The **Steyr Motors marine engine** is equipped with an electric fuel pump. It is turned “ON” and “OFF” with the key switch. If the engine is not started within 10 seconds after turning the key switch “ON”, the fuel pump is automatically turned off.

## Fuel System Checks

Fill the tank with the recommended fuel. Keeping tanks full reduces water condensation and helps keep fuel cool, which is important to engine performance.

Make sure that fuel supply valves (if used) are open, and valve cock seals are absolutely (gas) tight.

**NOTE:** Do not dry run fuel pump.

To insure a prompt start and an even run of the engine, the fuel system is to be rinsed by means of the electric fuel pump (ignition “ON” several times for app. 10 sec.) before starting the engine the first time and/or after every replacement of a fuel filter.

Refill fuel at the end of each day's operation to prevent condensation build up in tank. Condensation formed in a partially filled tank contaminates the fuel and promotes the growth of microbial organisms that can block fuel filters and restrict fuel flow.

If the engine is equipped with a fuel/water separator, drain off any water that has accumulated. Water in fuel can seriously affect engine performance and damage injection equipment reducing engine life expectancy.

**Steyr Motors** recommends installing a pre-fuel filter with water separating capability. The filter flow rate must allow a flow rate of 340 l/h with a maximum permissible pressure drop rate of less than 200 mbar.

## Fuel Contamination

In the marine environment, the most likely fuel contaminants are water and microbial growth (black “slime”). Generally, this type of contamination is the result of poor fuel handling practices. Black “slime” requires water in the fuel to form and grow; the best prevention is to change or refill the fuel regularly.

**NOTE:** A galvanized steel tank should never be used for fuel storage, because the fuel reacts chemically with the zinc coating forming powdery flakes which can quickly clog the fuel filters and damage the fuel pump and injectors.

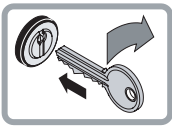

## External mounted fuel system version

This external mounted fuel system is available for all 6-cylinder as well as 4-cylinder Marine engine types from **Steyr Motors**.

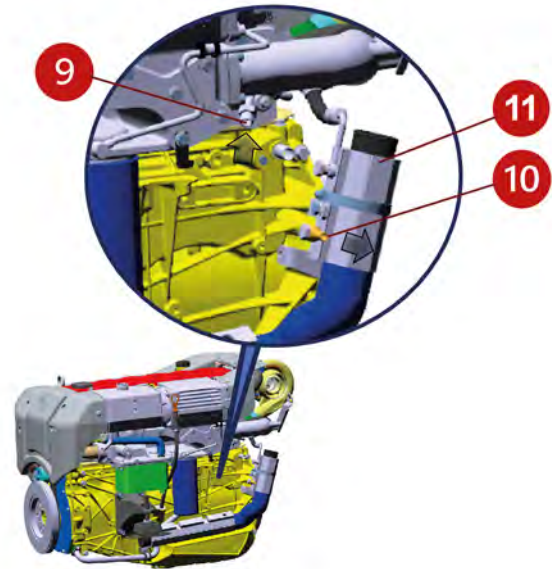
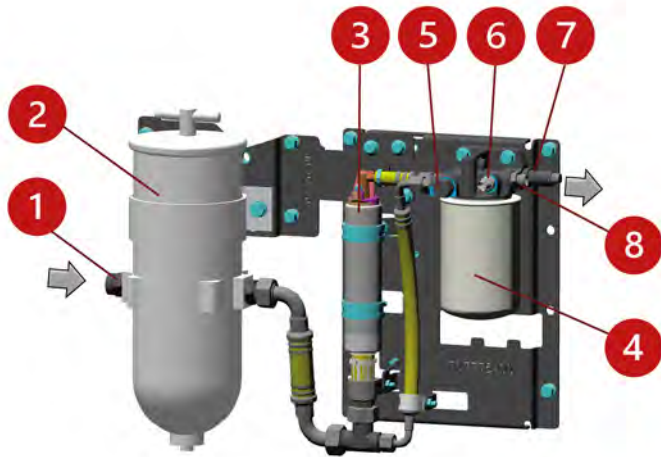

Item	Description
(1)	Fuel inlet connection (from fuel tank)
(2)	Fuel pre-filter
(3)	Electrical fuel pump
(4)	Fuel fine filter
(5)	Pressure relieve valve
(6)	Fuel temperature sensor

Item	Description
(7)	Fuel pressure sensor
(8)	Fuel outlet connection (to engine fuel inlet connection no. #9)
(9)	Engine fuel inlet connection
(10)	Engine fuel outlet connection (back to fuel tank)
(11)	Fuel cooler

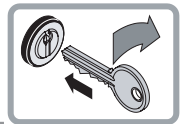

Basically, the **Steyr Motors** Marine engines are tested and certified, and meet following regulations / certifications:

**Regulations:**

- IMO Resolution MSC. 81 (70) Testing of Lifesaving Appliances
- Regulation (EU) 2022/1157, item No. MED/1.36. SOLAS 74 as amended, Regulation III/4, III/34 & X/3 and LSA Code
- DNV standard DNV-ST-E406 - Design of free-fall lifeboats

**Certifications:**

- TYPE APPROVAL CERTIFICATE  
Steyr Motors Certificate No: TAM00000DY
- EC-TYPE EXAMINATION CERTIFICATE (MODULE B)  
Steyr Motors Certificate No: MEDB000034E
- QS - CERTIFICATE OF ASSESSMENT - EC (MODULE E)  
Steyr Motors Certificate No: MEDE000000M

But in terms of the external fuel system the boat builder have to consider following:

As there is a wide variety of applications in the marine sector, it is in the responsibility of the boat builder to comply and to prove the application to the particular regulations (SOLAS, Lifeboat, etc). **Steyr Motors** cannot cover this variety of requirements and regulations with one fuel system. Therefore, some additional pre-measures must be done for each particular installation (e.g. splashguard, dip drain, etc) to fulfil the necessary regulations. For this reason, a standardised, externally installed fuel system for the marine sector is supplied.

Here we have to provide the following information:

The fuel hoses supplied, including the fitted fittings, comply with the following standards:

SAE J1527 Type A Class I, USCG SAE J1942, ISO 7840, USCH H, HF, German Lloyd, Lloyds RE.

According to the manufacturer's specifications, these hoses are permitted / approved for operation with the following media:

Gasoline, ethanol blends, diesel fuels, petroleum base hydraulic fluids, and lubricating oils.

System volume --> approximately 3.7 litres

[A] Basic position of external mounted fuel system:

Axis fuel supply port on fuel main filter head to engine block inlet (or even higher)

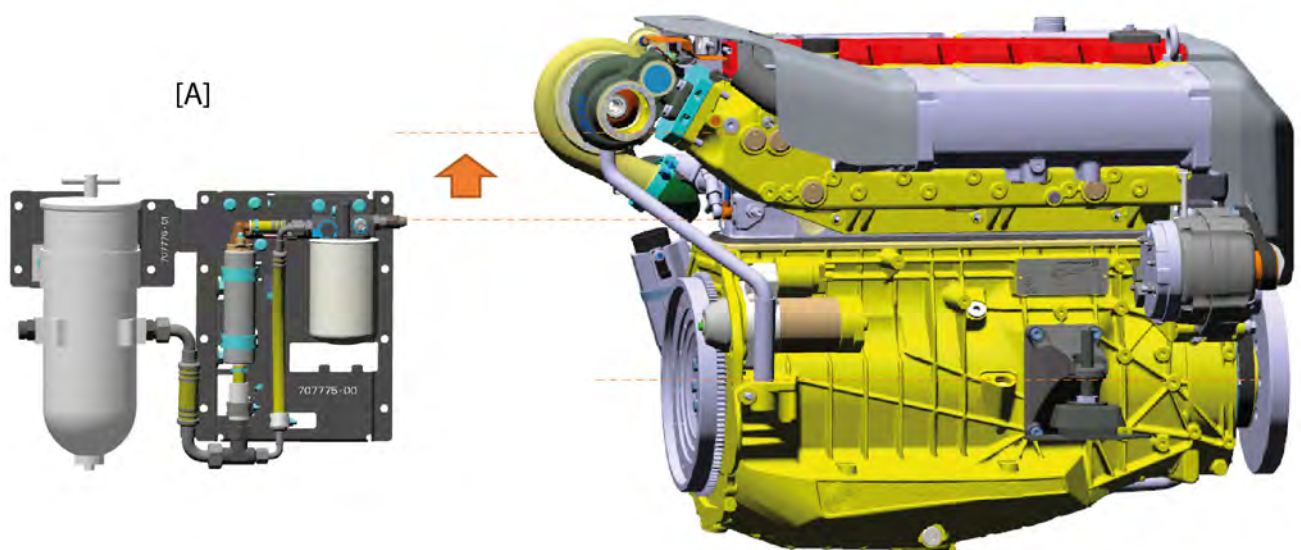

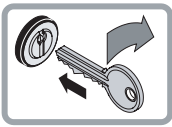

## Cooling System (Function Description 4 Cylinder Marine Engine)

Steyr Motors marine engines are equipped with a closed (internal) and an open (external cooling circuit).

### 7 Closed Cooling Circuit

The closed cooling circuit includes monoblock as well as exhaust manifold, heat exchanger and expansion tank. Temperature in the closed cooling circuit is precisely controlled by means of thermostat. The thermostat determines the amount of coolant circulating through the heat exchanger, thus controlling the operating temperature of the engine.

A temperature sensor (7/A) controls the cooling temperature. An excessive temperature rise of the coolant will cause an optical and audible alarm (see table “Error indication on Panel Section”). In this case, engine power will be reduced.

The temperature gauge on the instrument panel indicates the coolant temperature of the engine

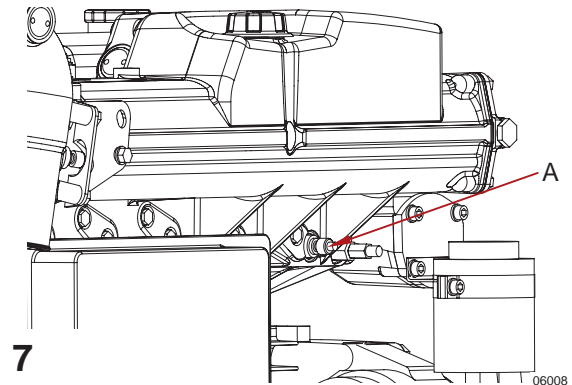

### 8 Open Cooling Circuit (Raw Water Circuit)

Thermal energy transferred by the engine and absorbed by the engine coolant is drained via the (external) raw water circuit. Raw water is sucked by the pump via the raw water intake, constantly pumped through intercooler and heat exchanger, and discharged together with the exhaust gas inside the exhaust elbow. In this passage the raw water exits through the exhaust pipe system.

A temperature sensor (8/A) monitors the raw water- and exhaust gas mix-temperature. An excessive rise will cause an optical and audible alarm (see table “Error indication on Panel Section”). In this case, the engine power will be reduced.

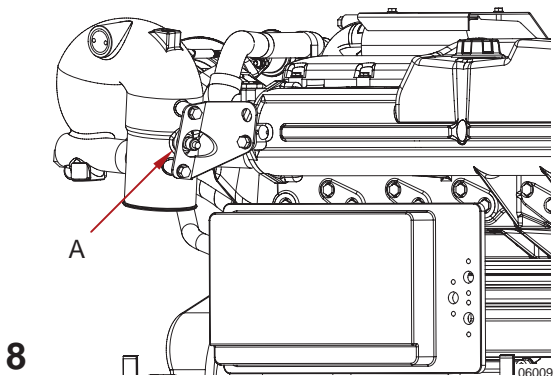

**NOTE:** Should engine overheat at high speeds, reduce RPM to idling to prevent damages to the engine. In case of overheating problems, contact your **Steyr Motors** Marine dealer.

In case of dry exhaust installation, contact your **Steyr Motors** Marine dealer for exhaust temperature sensor positioning.

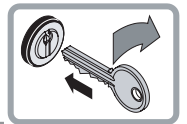

**Cooling System**  
 (Function Description 6 cylinder SE Marine Engine)

Steyr Motors Marine Engines are equipped with a closed (internal) and an open (external cooling circuit).

**9 Closed Cooling Circuit**

The closed cooling system consist of pressurized circuit and a expansion tank. The pressurized circuit consists of coolant distribution manifold, monoblock coolant jacket, exhaust manifold with thermostat and heat exchanger. The system pressure is controlled by a pressure cap on the expansion tank. The level of coolant in the expansion tank differs between cold and warmed up engine in a range of the min- & max-indicating marks. Temperature in the closed cooling circuit is controlled by means of thermostat. The thermostat determines the amount of coolant circulating through the heat exchanger, thus controlling the operating temperature of the engine.

A temperature sensor (**9/A**) controls the cooling temperature. An excessive temperature rise of the coolant will cause an optical and audible alarm (see table “Error indication on Panel Section”). In this case, engine power will be reduced.

The temperature gauge on the instrument panel indicates the coolant temperature of the engine.

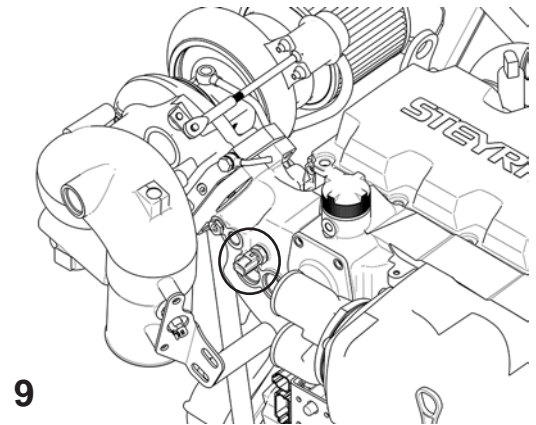

**10 Open Cooling Circuit (Raw Water Circuit)**

Thermal energy transferred by the engine and absorbed by the engine coolant is drained via the (external) raw water circuit. Raw water is sucked by the pump via the raw water intake, constantly pumped through intercooler and heat exchanger, and discharged together with the exhaust gas inside the exhaust elbow. In this passage the raw water exits through the exhaust pipe system.

A temperature sensor (**10/A**) monitors the raw water- and exhaust gas mix-temperature. An excessive rise will cause an optical and audible alarm (see table “Error indication on Panel Section”). In this case, the engine power will be reduced.

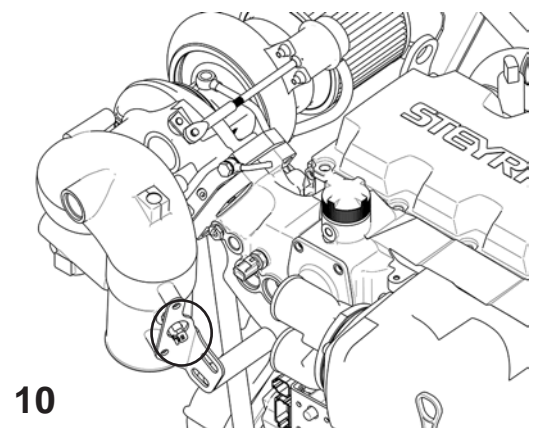

**NOTE:** Should engine overheat at high speeds, reduce RPM to idling to prevent damages to the engine. In case of overheating problems, contact your **Steyr Motors** Marine dealer.

In case of dry exhaust installation, contact your **Steyr Motors** Marine dealer for exhaust temperature sensor positioning.

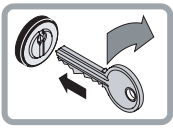

## Electrical Equipment

The electrical equipment of your **Steyr Motors marine engine** primarily consists of an alternator with transistorized voltage regulator, battery and all necessary connecting cables and leads.

**NOTE:** 24 V on board system requires a specified DC/DC-converter to supply the entire Engine Management System EMS with 12 V. For detailed instructions consult your authorized Steyr Motors Service Partner.

## Alternator

The alternator is driven via a **poly-v belt** to charge the battery at all engine speeds. Output at idle speed is limited to low amperage/voltage values and will rise with an engine speed to maximum output above 3000 revs.

### Optional:

Alternators are available with different outputs and voltages.

## Battery

### FOR ALL 4 CYL. MARINE ENGINES

Use a 12-volt battery with a cold testing circuit of 450 A at -18 °C and a **minimum capacity of 92 Ah** at 27 °C, to ensure the supply of the electric and electronic components at all operating conditions.

### FOR ALL 6 CYL. MARINE ENGINES

Use a 12-volt battery with a cold testing circuit of 650 A at -18 °C and a **minimum capacity of 115 Ah** at 27 °C, to ensure the supply of all electric and electronic components.

**ATTENTION:** \* **Do not use jumper cables and a booster battery to start engine. Remove battery from boat and recharge.**

**- WRONG CONNECTION WILL DESTROY ELECTRONIC SYSTEM -**



\* **Do not charge battery in boat. Fumes vented during battery charging can lead to an explosion.**

\* **Battery electrolyte is a corrosive acid and should be handled with care.**

If electrolyte is spilled or splashed on any part of the body, immediately flush the exposed area with liberal amounts of water and obtain medical aid as soon as possible.

High resistance in the charging circuit can seriously affect the operation of the electrical system. Unless there is definite malfunction in the electrical system, high resistance is sometimes caused by corroded or loose connections. Wherever practical, the electrical connections on your engine have been sealed. However, we recommend that you make periodic inspections to ensure clean, tight connections throughout the electrical system.

**NOTE:** It is important that the battery connections are correct. The negative battery cable must be attached to the negative terminal (-) on the battery and the engine's positive cable must be attached to the positive terminal (+) on the battery. **If these connections are reversed, the regulating unit may be immediately damaged.**

Inspect your battery at regular intervals for specific gravity (state of charge), individual cell water level, cleanliness and clean, tight connections.

If the battery has become discharged for no apparent reason, check all electrical system components for malfunction, or a switch left in ON position prior to installing recharged battery.

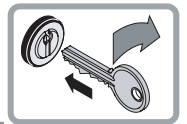

## Circuit Breakers & Fuses 4 Cylinder Marine Engine

Steyr Motors marine engine models are protected against overload by circuit breakers.

**11** On the base plate of the E-box three thermal triggered 50 amp. circuit breakers are installed. **(F2)** protects the electric circuit of the glow plugs of cylinder 1 & 2; **(F3)** protects the electric circuit for the glow plugs of cylinder 3 & 4; **(F1)** protects electric system and electronic management. The ignition key and instruments are protected by a 10 amp. Fuse located in the main wiring harness **beneath instrument panel** (location ignition key).

- F4** Fuse supply module
- F5** Fuse main circuit supply
- F6** Fuse fuel-pump circuit
- F7** Fuse glow-plug circuit
- F9** Fuse ignition switch circuit (instrument panel)

**NOTE:** Fuses for fuel, ECU-supply, glow plug-relay are inside the E-box cover.

**11**

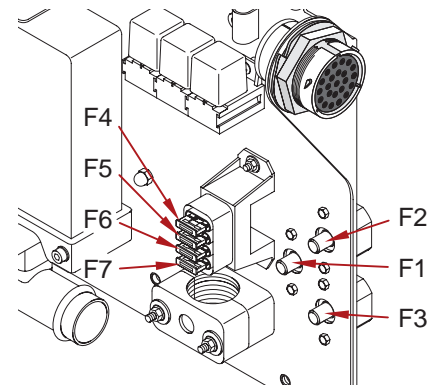

06011

## Circuit Breakers & Fuses 6 Cylinder SE Marine Engine

Steyr Motors marine engine models are protected against overload by circuit breakers.

**12** The base plate of the E-box carries 6 different thermal triggered circuit breakers.

### Fuse Protection Level and Function

- F1** 20 Amp Fuse VBatt Main Relay
- F2** 25 Amp Fuse fuel-pump circuit
- F3** 20 Amp Fuse ECU circuits
- F4** 50 Amp Fuse glow-plug circuit
- F5** 50 Amp Fuse glow-plug circuit
- F6** 12,5 Amp Fuse D+ Alternator Terminal

**12**

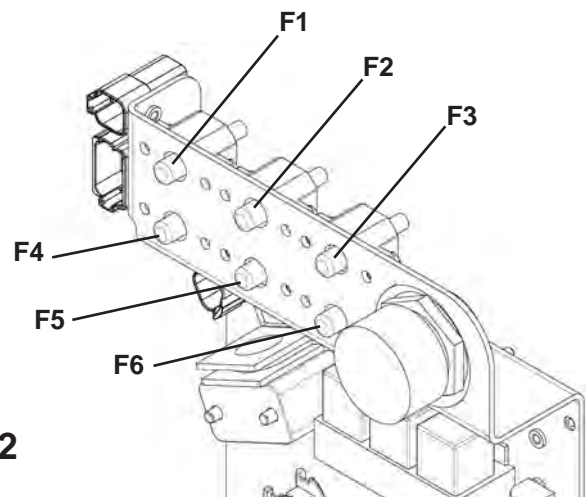

**NOTE:** Avoid sparks that will damage the alternator or ECU. Do not attempt to connect or disconnect any part of the electrical system while the engine is running.

**NOTE:** The installation of any additional electrical accessories requires the protection of individual circuits. Consumption of current should occur directly at the battery.

**NOTE:** If the automatic electric circuit breaker is more than 10 times triggered a preventive replacement is recommended.

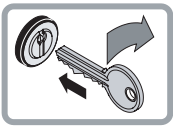

### Inversion Switch (optional)

- 13** The inversion switch (**A**) which is actuated in case of an inclination of the boat in any direction over 70 °. Via the main circuit relay the engine is shut down. **For safe guarding reasons the inversion switch must be checked according to the Service and Maintenance Schedule.**

**CAUTION:**



After such an event, this temporarily stored operating condition is to be cancelled from the engine management system by ignition "OFF" = "Reset". Without "Reset", a new start of the engine is not possible.

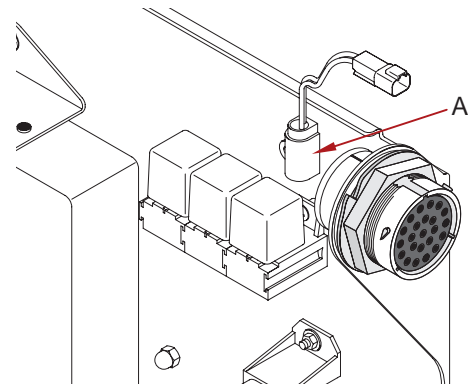

06012

Series MO

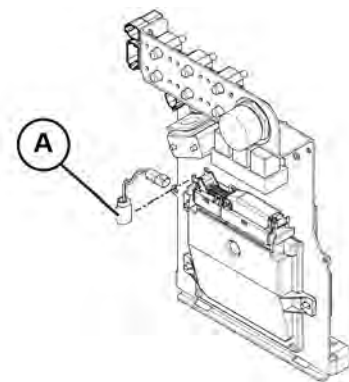

Series SE

**13**

### Interrupt crankshaft housing ventilation (optional)

- 15** During possible vessel inversion, the by-pass valve (**B**) for crankshaft housing ventilation is closed too. This avoids a possible oil outlet via suction through the air filter.

### Instrument Panel

The engines are supplied with the standard instrument panel. The respective customer may use a self-adapted **Steyr Motors** instrument panel or one which corresponds to his own ideas and requirements.

**CAUTION:**



For not approved alterations which lead to engine failure, no liability can be undertaken.

**15**

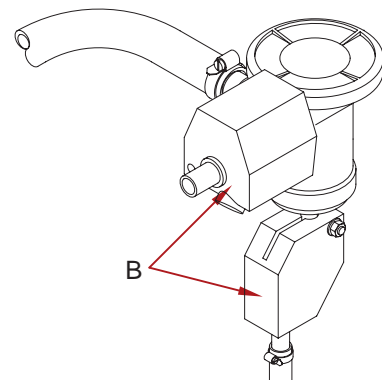

06010

### Dry Operation

After a dry operation of the engine (without raw water cooling), check the impeller of the raw water pump for damages. Replace if necessary. Grease the impeller, use grease from genuine impeller service kit (see adequate spare parts catalogue).

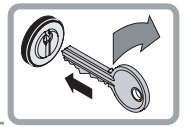

This Page is intentionally blank



## FUEL AND LUBRICANTS

Fuel Requirements .....	53
How to Select Fuel .....	53
Filter Maintenance & Service.....	53
Engine Lubrication.....	54
Engine Oil .....	54
Oil Identification Symbol.....	54
Disposal of Automotive Waste Products.....	55



## Fuel Requirements

The **Steyr Motors Marine Engines** are designed for maximum fuel economy. To maintain specified performance, use diesel fuel according to EN 590 or equivalent.

## How to Select Fuel

Fuel quality is an important factor in obtaining satisfactory engine performance, long engine life, and acceptable exhaust emission levels. Direct injected diesel engines are designed to operate with most diesel fuels marketed today.

### **NOTE:**

Some fuels decrease the service interval of the engine!

Service interval should be changed to suit the fuel in use, for the most up to date information on acceptable fuel types please refer to our website [www.steyr-motors.com](http://www.steyr-motors.com).

## Filter Maintenance & Service

Steyr Motors recommends the use of a fuel prefilter/water separator (set no.: MS1203010) for the SE motor series. Contact an authorized Steyr Motors dealer.

Refer to the maintenance table for service intervals for pre-filters and fine filters;  
If necessary, follow the fuel contamination and manufacturer's instructions.



## Engine Lubrication

If you choose to lubricate your **Steyr Motors Marine Engine** yourself, refer to the **Lubrication and Inspection Chart** for lubrication points and recommended lubricants. Use only Steyr Motors recommended lubricants or lubricants of equivalent quality and viscosity. See your Steyr Motors dealer for recommended lubricants.

If you choose to have your **Steyr Motors Marine Engine** lubricated, see your local dealer.

## Engine Oil

To obtain the best engine performance and engine life, Steyr Motors High Performance Diesel Engine Oil Z050316-4 is recommended. If Steyr Motors High Performance Diesel Engine Oil is not available, it is required to use a reputable brand of engine oil labelled for

- SAE 10W-40
- ACEA E6/E7
- API CI-4/CH-4/CG-4/CF-4,CF:

Refer to oil identification symbol on the container.

During the break-in period (initial 20 hours), frequently check the oil level. Higher oil consumption is normal until cylinder system is stabilized. The oil level should be maintained between the minimum and maximum mark on the dipstick. The space between the marks represents approximately 3.7 quarts (3.5 litres). For oil level dipstick location, refer to your authorized Steyr Motors dealer.

### NOTE:

Optional there are two different oil dip sticks available according to the engine storage inclination. After first 50 hours of operation change the engine oil and replace the oil filter. Refer to Service and Maintenance Schedule.

## Oil Identification Symbol

Engine oils are specified by ACEA, API service code and SAE viscosity numbers. These may be found on the label, top of can, or API service symbol.

### NOTE:

Some engine oils have several ACEA / API quality ratings. The recommended ACEA / API service letter code must be among these quality ratings.

Steyr Motors Betriebs GmbH has no values regarding the oil- & fuel- consumption, when a not known oil is in use. Refer to F1 - List of operating material



Top of can

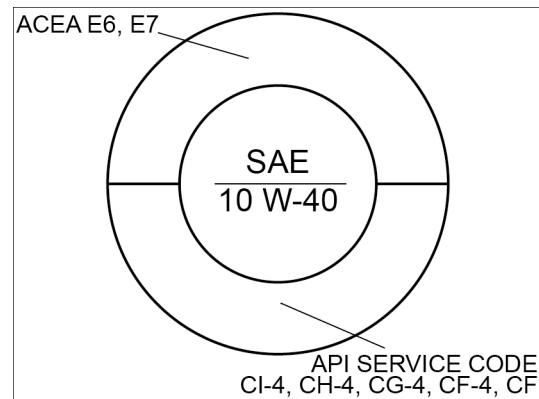

Oil identification symbol

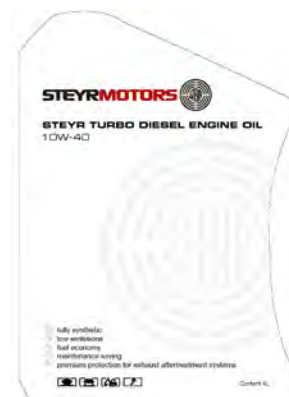

Oil sticker



## Disposal of Automotive Waste Products

Used fuel and oil is to be collected in separate containers to permit an eventual subsequent treatment.



**THE DISPOSAL OF ANY FUEL AND OIL FOR THE ENGINE IS SUBJECT TO THE SPECIAL WASTE ACT. THE "SPECIAL WASTE CATALOGUE" ÖNORM S2100 REFERS TO THE NECESSARY DISPOSAL IN AUSTRIA. PLEASE FOLLOW THE LOCAL REGULATIONS OF YOUR COUNTRY.**

The operating and maintenance personnel has to take care that fuel and oil as well as other material ranking as special waste are deposited at the respective collecting points.

Code No.	Designation
31 423	oil contaminated ground or oil binder
54 102	waste oil
54 104	fuel
54 202	grease
54 207	vaseline
54 917	compact sealing material
54 927	oil contaminated scouring cloth
54 928	used oil- and air filters
55 510	colour- or varnish containing waste

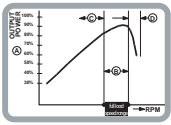

## TECHNICAL DATA

Model and Serial Numbers .....	57
Technical Data and Overview MO84K32, MO94K33, MO114K33.....	58
Technical Data and Overview MO144M38, MO164M40, MO174V40 .....	60
Technical Data and Overview SE164E40, SE144E38 .....	62
Technical Data and Overview SE-Engines .....	64

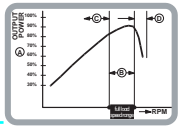

## Model and Serial Numbers

The model and serial number (see fig. 15/16) is located on the engine as illustrated.

**These numbers are required for warranty claims and ordering parts.**

### 4 CYL. MARINE ENGINES (Series MO)

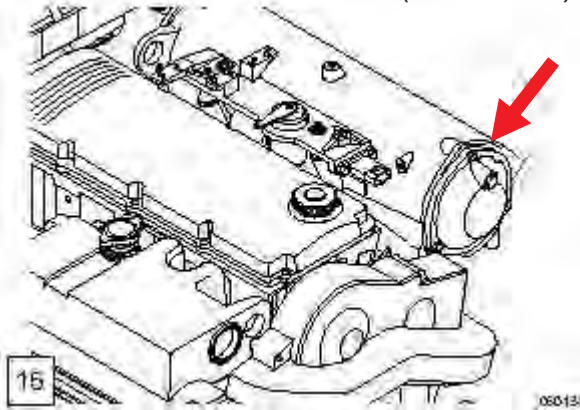

### FOR ALL 6 CYL. MARINE ENGINES

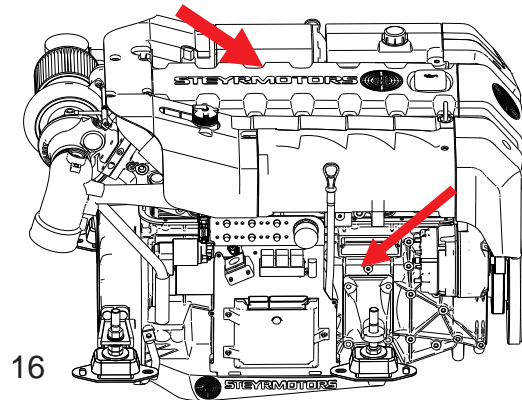

### 4 CYL. MARINE ENGINES (Series SE)

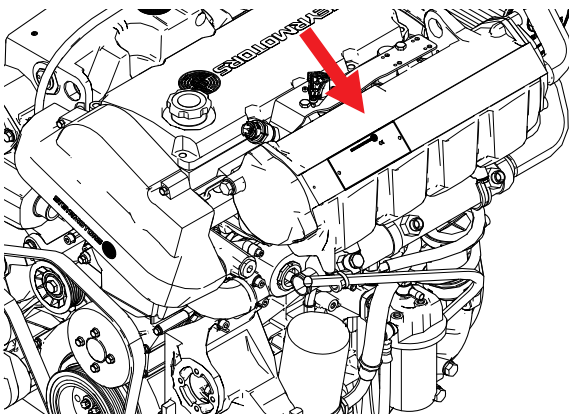

**17** The model and serial number of the marine gearbox is located on the marine gearbox housing as illustrated.



To obtain instructions regarding marine gearbox operation, refer to marine gearbox owners manual.

**17**

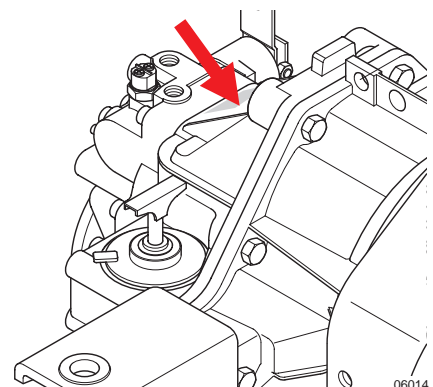

06014

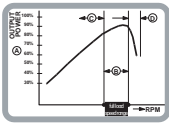

**Technical Data and Overview MO84K32, MO94K33, MO114K33**

<b>MAKE</b>	<b>Steyr Motors M 14 TCM, TCAM</b>		
type	<b>MO84K32</b>	<b>MO94K33</b>	<b>MO114K33</b>
displacement	2133 cm <sup>3</sup>		
piston displacement	85,0 x 94,0 mm		
rated power acc. EN ISO 8665:2006 (impeller*) KW/HP Jet – Drive/Inboard Z – Drive	53/71 52/70	64/86 63/84	78/105 77/104
number of cylinders	4-cylinder in-line engine (position of cyl. 1 at vibration damper side)		
ignition order	1 – 3 – 4 – 2		
sense of rotation, seen from front	right		
compression ratio	17,5:1		
propped speed range (rpm)	3200 rpm (+0 rpm/–200 rpm)	3300 rpm (+0 rpm/–200 rpm)	3300 rpm (+0 rpm/–200 rpm)
idle speed	700 rpm (adjustable)		
injection	Plunger activated, two stage, high pressure with electronically controlled injection rate		
fuel	acc. to CEC RF-03-A-84 (DIN EN 590) Cetan >49; diesel fuel No. 2-D, temperature above –7 °C; No.1-D, temperature below –7 °C		
fuel filter	refer to spare part catalogue		
fuel filter location	intake-sided		
air filter	refer to spare part catalogue		
oil pressure above 2000 rpm	400 – 700 kPa (58 – 101 PSI) microprocessor controlled		
filling capacity motor oil	approx. 8,0 l engine housing (incl. approx. 1 l oil filter contents)		
specification motor oil	SAE 10W-40 ACEA E6/E7 API CI-4/CH-4/CG-4/CF-4,CF P/No. Z050316-4		
oil and oil filter change intervals**)	every 150 operating hours and/or once per season		
oil filter	refer to spare part catalogue		
oil filter location	pressure-sided		
electric charging system	14 V/90 A alternator with transistorized voltage regulator		
cooling system	dual cooling circuit; thermostat-controlled, pressurized cooling circuit; circulating pump with heat exchanger on engine; governor pump, external raw water circuit to heat exchange		
coolant capacity	11,5 liters		
coolant	Steyr Motors engine coolant –36 °C P/No. Z011785-0, ready mixed		

\*) Efficiency of gearbox = 97,0 %, efficiency of Z-Drive = 95,5 %

\*\*\*) Extended periods to be evaluated upon application and type of usage Steyr Motors Betriebs GmbH.  
Reserves the right to make changes without notice or obligations.

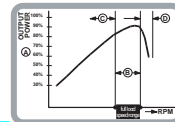

**Overview for all STEYR MOTORS 4 Cyl. Marine Engines**

Item	Designation
1	Zinc Anode (4 Units)
2	Model and Serial Number
3	Intercooler
4	Fuel/Oil Cooler with Raw Water Drain Plug
5	Fuel Pump
6	Oil Seperator
7	Raw Water Drain Plug
8	Valve Crankshaft Housing Ventilation (only SOLAS)
9	Oil Drain Plug
10	Fuel Filter
11	Oil Filter
12	Hydraulic Pump
13	Raw Water Inlet Fitting
14	Raw Water Pump
15	Coolant Drain Plug (2 Units)
16	Engine Oilcooler
17	Oil Suction Pipe
18	Oil Dipstick
19	Hydraulic Oil Tank
20	Cooler Cap
21	Potentiometer Accelerator
22	Motor Oil Filler Cap
23	Boost Pressure Sensor
24	Rack Position Sensor*)
25	Drive Belt
26	Cover T-Belt, Lower
27	Engine Mount
28	Drive Belt Tensioner
29	Vibration Damper
30	Cover T-Belt, Upper
31	Engine Lifting Eye
32	Speed Sensor
33	Valve Cover
34	Heat Exchanger
35	Coolant Expansion Tank
36	Diagnostic Outlet
37	Inversion Switch (only for SOLAS)
38	Connector Instrument Panel
39	Coolant Temperature Sensor
40	Thermostat Housing
41	Alternator
42	Circuit Breakers
43	Engine Management System/Fuses
44	Exhaust Temperature Sensor
45	Air Filter
46	Turbo Charger
47	Exhaust Elbow
48	Starter Relais (Backside E-Box Ground Plate)
49	Starter Motor
50	Flywheel
51	Flywheel Housing
52	Oil Pressure Sensor

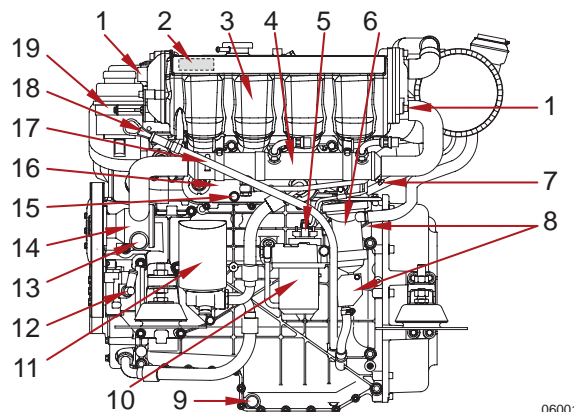

06001

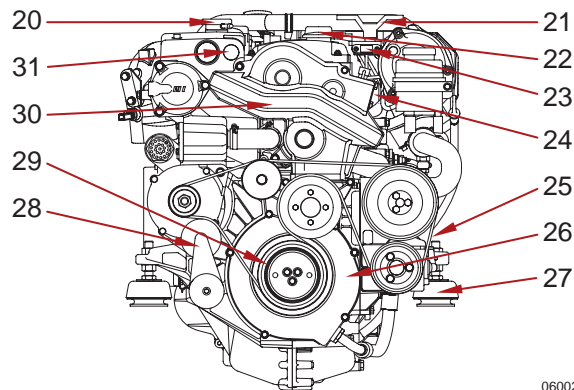

06002

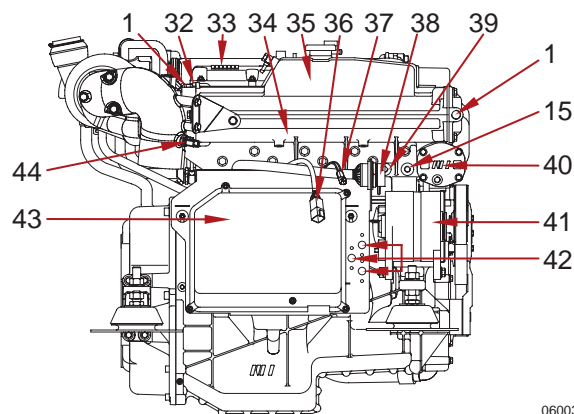

06003

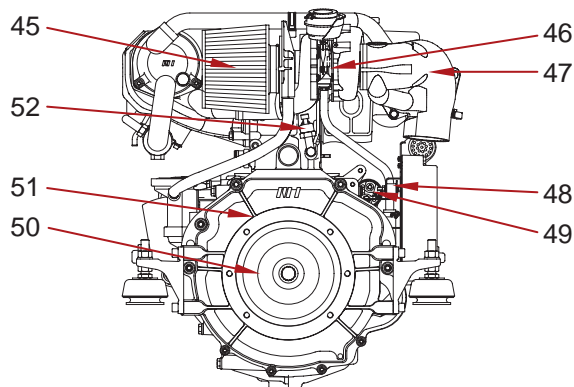

06004

\*) This sensor is magnetism sensitive. All external magnets must be kept away.

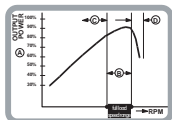

## Technical Data and Overview MO144M38, MO164M40, MO174V40

MAKE	Steyr Motors M 14 TCAM		
	MO144M38	MO164M40	MO174V40
type			
displacement	2133 cm <sup>3</sup>		
piston displacement	85,0 x 94,0 mm		
rated power acc. EN ISO 8665:2006 (impeller*) KW/HP			
Jet – Drive/Inboard	103/138	116/156	121/165
Z – Drive	101/136	114/154	119/162
number of cylinders	4-cylinder in-line engine (position of cyl. 1 at vibration damper side)		
ignition order	1 – 3 – 4 – 2		
sense of rotation, seen from front	right		
compression ratio	17.5:1		17.0:1
propped speed range (rpm)	3800 rpm (+0 rpm/–300 rpm)	4000 rpm (+0 rpm/–300 rpm)	4000 rpm (+0 rpm/–300 rpm)
idle speed	700 rpm (adjustable)		
injection	Plunger activated, two stage, high pressure with electronically controlled injection rate		
fuel	acc. to CEC RF-03-A-84 (DIN EN 590) Cetan >49; diesel fuel No. 2-D, temperature above –7 °C; No.1-D, temperature below –7 °C		
fuel filter	refer to spare part catalogue		
fuel filter location	intake-sided		
air filter	refer to spare part catalogue		
oil pressure above 2000 rpm	400 – 700 kPa (58 – 101 PSI) microprocessor controlled		
filling capacity motor oil	approx. 8,0 l engine housing (incl. approx. 1 l oil filter contents)		
specification motor oil	SAE 10W-40 ACEA E6/E7 API CI-4/CH-4/CG-4/CF-4,CF P/No. Z050316-4		
oil and oil filter change intervals**)	every 150 operating hours and/or once per season		
oil filter	refer to spare part catalogue		
oil filter location	pressure-sided		
electric charging system	14 V/90 A alternator with transistorized voltage regulator		
cooling system	dual cooling circuit; thermostat-controlled, pressurized cooling circuit; circulating pump with heat exchanger on engine; governor pump, external raw water circuit to heat exchange		
coolant capacity	11,5 liters		
coolant	Steyr Motors engine coolant –36 °C P/No. Z011785-0, ready mixed		

\*) Efficiency of gearbox = 97,0 %, efficiency of Z-Drive = 95,5 %

\*\*\*) Extended periods to be evaluated upon application and type of usage Steyr Motors Betriebs GmbH.  
Reserves the right to make changes without notice or obligations.

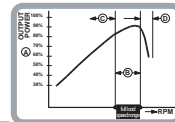

**Overview for all STEYR MOTORS 4 Cyl. Marine Engines**

Item	Designation
1	Zinc Anode (4 Units)
2	Model and Serial Number
3	Intercooler
4	Fuel/Oil Cooler with Raw Water Drain Plug
5	Fuel Pump
6	Oil Seperator
7	Raw Water Drain Plug
8	Valve Crankshaft Housing Ventilation (only SOLAS)
9	Oil Drain Plug
10	Fuel Filter
11	Oil Filter
12	Hydraulic Pump
13	Raw Water Inlet Fitting
14	Raw Water Pump
15	Coolant Drain Plug (2 Units)
16	Engine Oilcooler
17	Oil Suction Pipe
18	Oil Dipstick
19	Hydraulic Oil Tank
20	Cooler Cap
21	Potentiometer Accelerator
22	Motor Oil Filler Cap
23	Boost Pressure Sensor
24	Rack Position Sensor*)
25	Drive Belt
26	Cover T-Belt, Lower
27	Engine Mount
28	Drive Belt Tensioner
29	Vibration Damper
30	Cover T-Belt, Upper
31	Engine Lifting Eye
32	Speed Sensor
33	Valve Cover
34	Heat Exchanger
35	Coolant Expansion Tank
36	Diagnostic Outlet
37	Inversion Switch (only for SOLAS)
38	Connector Instrument Panel
39	Coolant Temperature Sensor
40	Thermostat Housing
41	Alternator
42	Circuit Breakers
43	Engine Management System/Fuses
44	Exhaust Temperature Sensor
45	Air Filter
46	Turbo Charger
47	Exhaust Elbow
48	Starter Relais (Backside E-Box Ground Plate)
49	Starter Motor
50	Flywheel
51	Flywheel Housing
52	Oil Pressure Sensor

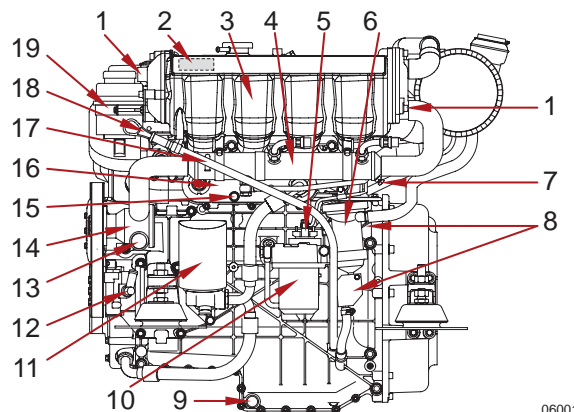

06001

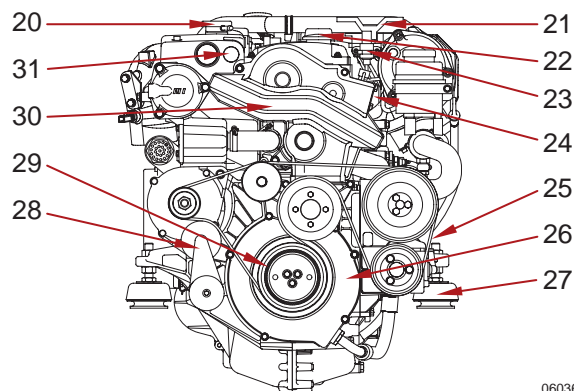

06036

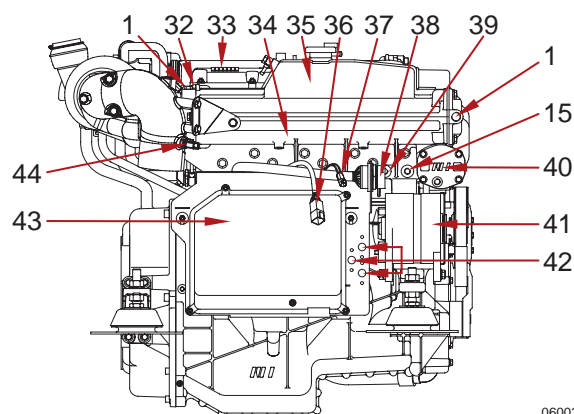

06003

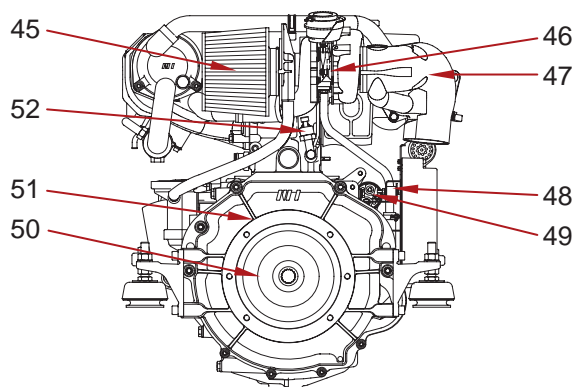

06004

\*) This sensor is magnetism sensitive. All external magnets must be kept away.

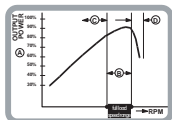

## Technical Data and Overview SE164E40, SE144E38

MAKE	Steyr Motors	
type	SE164E40	SE144E38
displacement	2133 cm <sup>3</sup>	
piston displacement	85,0 x 94,0 mm	
rated power acc. EN ISO 8665:2006 (impeller*) KW/HP Jet – Drive/Inboard Z – Drive	118/160 114,5/155.7 116,2/158	106/144 102,8/139.8 104,4/142
number of cylinders	4-cylinder in-line engine (position of cyl. 1 at vibration damper side)	
ignition order	1 – 3 – 4 – 2	
sense of rotation, seen from front	right	
compression ratio	17.0:1	
propped speed range (rpm)	4000 rpm (+100 rpm/–100 rpm)	3800 rpm (+100 rpm/–100 rpm)
idle speed	750 rpm (adjustable)	
injection	Plunger activated, two stage, high pressure with electronically controlled injection rate, timing	
fuel	EN 590	
fuel filter	2203710-0	
fuel filter location	intake-sided	
air filter	refer to spare part catalogue	
oil pressure above 2000 rpm	400 – 700 kPa (58 – 101 PSI) microprocessor controlled	
filling capacity motor oil	approx. 8,4 l engine housing (incl. approx. 1 l oil filter contents)	
specification motor oil	SAE 10W-40 ACEA E6/E7 API CI-4/CH-4/CG-4/CF-4,CF P/No. Z050316-4	
oil and oil filter change intervals**)	according to service and maintenance schedule	
oil filter	refer to spare part catalogue	
oil filter location	pressure-sided	
electric charging system	14 V/120 A alternator with transistorized voltage regulator	
cooling system	dual cooling circuit; thermostat-controlled, pressurized cooling circuit; circulating pump with heat exchanger on engine; governor pump, external raw water circuit to heat exchange	
coolant capacity	9 liters	
coolant	Steyr Motors engine coolant –36 °C P/No. Z011785-0, ready mixed	

\*) Efficiency of gearbox = 97,0 %, efficiency of Z-Drive = 95,5 %

\*\*\*) Extended periods to be evaluated upon application and type of usage Steyr Motors Betriebs GmbH.  
Reserves the right to make changes without notice or obligations.

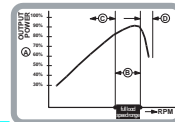

**Overview for all STEYR MOTORS 4 Cyl. Marine Engines**

Item	Designation
1	Zinc Anode (2 Units)
2	Model and Serial Number
3	Intercooler
4	Fuel/Oil Cooler with Raw Water Drain Plug
5	Fuel Pump
6	Oil Seperator
7	Raw Water Drain Plug
8	Crankshaft Housing Ventilation
9	Oil Drain Plug
10	Fuel Filter
11	Oil Filter
12	Raw Water Inlet Fitting
13	Water Pump
14	Coolant Drain Plug
15	Engine Oilcooler
16	Oil Dipstick
17	Cooler Cap
18	Potentiometer Accelerator
19	Motor Oil Filler Cap
20	Boost Pressure Sensor
21	Rack Position Sensor*)
22	Drive Belt
23	Cover T-Belt, Lower
24	Engine Mount
25	Drive Belt Tensioner
26	Vibration Damper
27	Cover T-Belt, Upper
28	Engine Lifting Eye
29	Speed Sensor
30	Valve Cover
31	Heat Exchanger
32	Coolant Expansion Tank
33	Diagnostic Outlet
34	Inversion Switch (only for SOLAS)
35	Connector Instrument Panel
36	Coolant Temperature Sensor
37	Thermostat Housing
38	Alternator
39	Circuit Breakers
40	Engine Management System/Fuses
41	Air Filter
42	Turbo Charger
43	Exhaust Elbow
44	Starter Relais (Backside E-Box Ground Plate)
45	Starter Motor
46	Flywheel
47	Oil Pressure Sensor
48	Exhaust Temperature Sensor (without illustration)
49	Raw water outlet

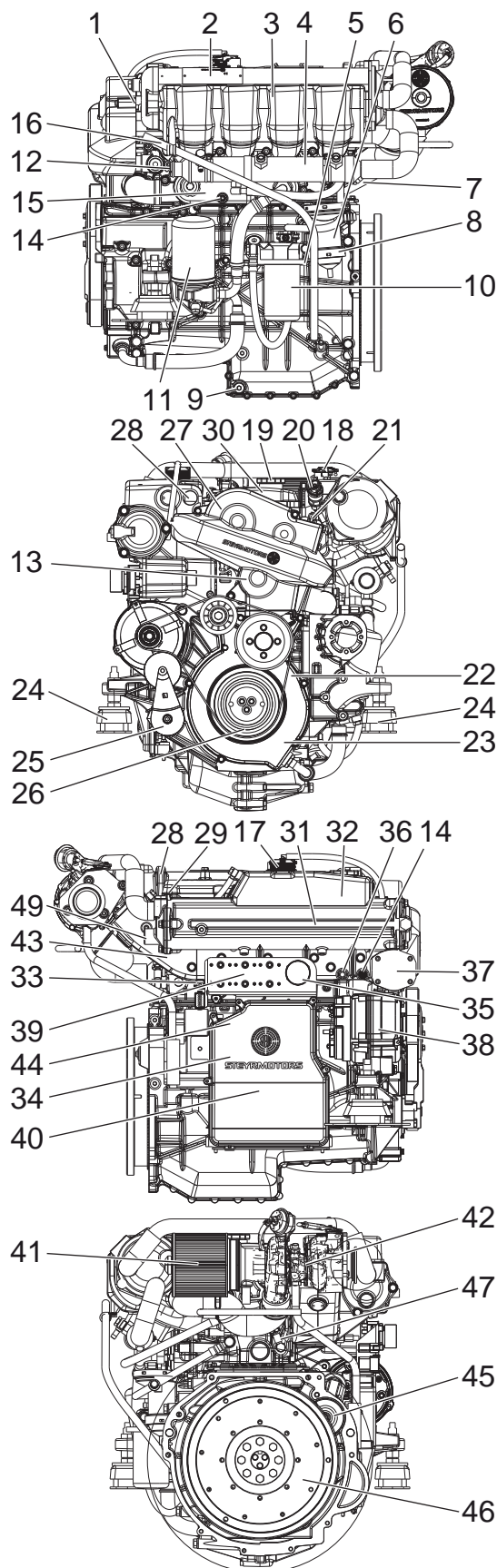

\*) This sensor is magnetism sensitive. All external magnets must be kept away.

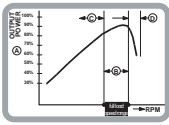

## Technical Data and Overview SE-Engines

MAKE	Steyr Motors M 16 TCM, TCAM
type	SE-Engines
displacement	3200 cm <sup>3</sup>
piston displacement	85,0 x 94,0 mm
number of cylinders	6-cylinder in-line engine (position of cyl. 1 at vibration damper side)
ignition order	1 – 5 – 3 – 6 – 2 – 4
sense of rotation, seen from front	right
compression ratio	17:1
propped speed range (rpm)	refer to chapter 1 – marine engine overview
idle speed	630 rpm (adjustable)
injection	Plunger activated, two stage, high pressure with electronically controlled injection rate
fuel	acc. to CEC RF-03-A-84 (DIN EN 590) Cetan >49; diesel fuel No. 2-D, temperature above –7 °C; No.1-D, temperature below –7 °C
pre- & main fuel filter	refer to spare part catalogue
fuel filter location	pressure-sided
air filter	refer to spare part catalogue
filling capacity motor oil	approx. 16,0 l engine housing (incl. approx. 1 l oil filter contents)
specification motor oil	SAE 10W-40 ACEA E6/E7 API CI-4/CH-4/CG-4/CF-4,CF P/No. Z050316-4
oil and oil filter change intervals**)	according to service and maintenance schedule
oil filter	refer to spare part catalogue
oil filter location	pressure-sided
cooling system	dual cooling circuit; thermostat-controlled, pressurized cooling circuit; circulating pump with heat exchanger on engine; governor pump, external raw water circuit to heat exchange
coolant capacity	13,2 liters
coolant	Steyr Motors engine coolant –36 °C P/No. Z011785-0, ready mixed

\*) Efficiency of gearbox = 97,0 %, efficiency of Z-Drive = 95,5 %

\*\*\*) Extended periods to be evaluated upon application and type of usage Steyr Motors Betriebs GmbH.  
Reserves the right to make changes without notice or obligations.

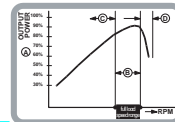

**Overview STEYR MOTORS SE-Series**

Item	Designation
1	Boost Pressure Sensor
2	Zinc Anode (3 Units)
3	Intercooler
4	Fuel Cooler
5	Engine Oilcooler
6	Model and Serial Number
7	Oil Seperator
8	Raw Water Drain Plug
9	Valve Crankshaft Housing Ventilation
10	Fuel Filter
11	Fuel Pump
12	Oil Filter
13	Raw Water Inlet Fitting
14	Raw Water Pump
15	Coolant Drain Plug
16	Oil Suction Pipe
17	Oil Dipstick
18	Rack Position Sensor *)
19	Engine Lifting Eye
20	Motor Oil Filler Cap
21	Potentiometer Accelerator
22	Drive Belt, Raw Water Pump
23	Engine Mount
24	Drive Belt Tensioner
25	Cover T-Belt, Lower
26	Vibration Damper
27	Speed Sensor
28	Cover T-Belt, Upper
29	Cover Rear
30	Valve Cover
31	Heat Exchanger
32	Coolant Expansion Tank
33	Cooler Cap
34	Diagnostic Outlet
35	Inversion Switch
36	Connector Instrument Panel
37	Coolant Temperature Sensor
38	Thermostat Housing
39	Hydraulic Oil Tank
40	Circuit Breakers
41	Alternator
42	Hydraulic Pump
43	Oil Drain Plug
44	Starter Motor
45	Engine Management System/Fuses
46	Exhaust Temperature Sensor
47	Air Filter
48	Turbo Charger
49	Exhaust Elbow
50	Starter Relais (Backside E-Box Ground Plate)
51	Flywheel
52	Flywheel Housing
53	Oil Pressure Sensor
54	Hydraulic Oil Cooler

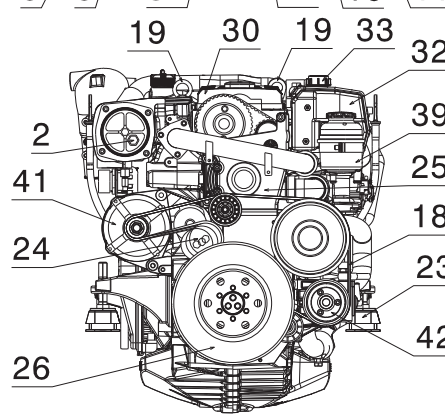
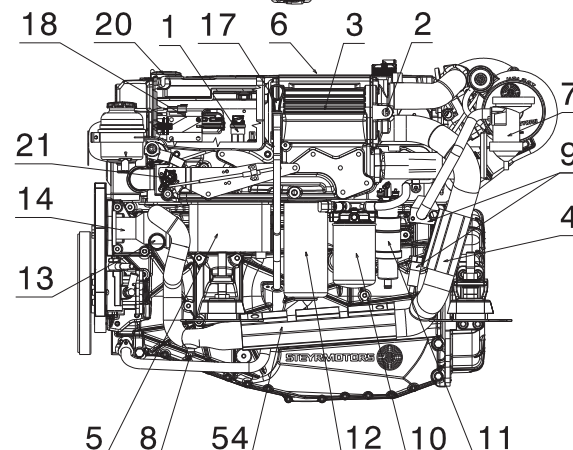
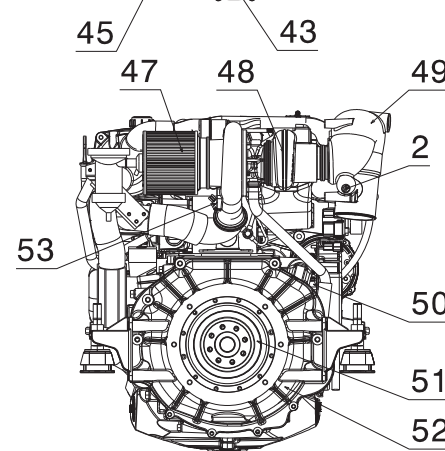
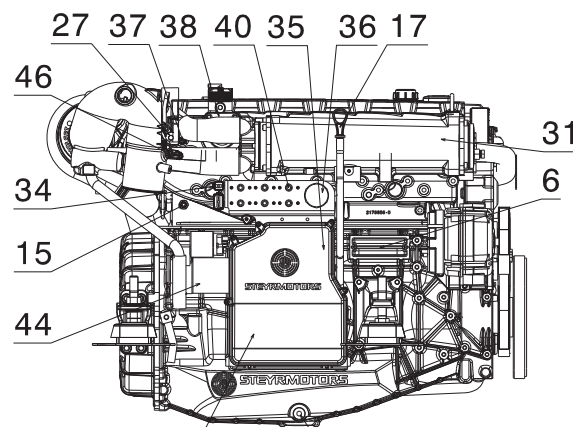

\*) This sensor is magnetism sensitive. All external magnets must be kept away.

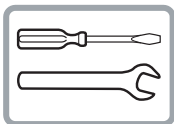

## MAINTENANCE AND TROUBLE SHOOTING

FOREWORD .....	68
IMPORTANT NOTE.....	68
MO Service- and Maintenance Schedule .....	69
SE Service- and Maintenance Schedule .....	72
SE Service- and Maintenance Schedule .....	75
MAINTENANCE LOG.....	78
Table - Error Indication on Instrument Panel .....	80
Table - Error Indication on Instrument Panel (for SOLAS only) .....	82
Principle service code list "SE" engines .....	84
Principle failure code list "MO" engines.....	88
Trouble Check Chart .....	90
Wiring harness 4-cylinder "MO" engines .....	92
Wiring diagram MO 12 V, 4-cyl.....	93
Wiring diagram MO 24 V, 4-cyl.....	94
Wiring diagram MO 12 V, 2 pol, 4-cyl.....	95

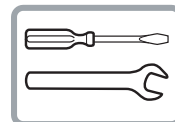

Wiring diagram MO 24 V, 2 pol, 4-cyl. ....96

Wiring diagram MO E-Box external, 4-cyl. ....97

Wiring diagram MO E-Box external, 2-pol, 4-cyl. ....98

Wiring diagram MO 12 V, 6-cyl.....99

Wiring diagram MO 12 V, 2 pol, 6-cyl. ....100

Wiring diagram MO 24 V, 2 pol, 6-cyl. ....101

Description - Wiring harness instrument panels 4 cyl. marine engines...102

Wiring diagram SE E-Box 12V, 6 cyl. ....103

Wiring diagram SE E-Box 24V, 6 cyl. ....104

Wiring diagram external SE E-Box, 6 cyl.....105

Wiring diagram SE E-Box 12 V, 4 cyl. ....106

Wiring diagram external SE E-Box 12 V, 4 cyl. ....107

Wiring diagram Instument CAN Panel 12/24V .....108

Wiring diagram Instument CAN Panel Solas 12/24V .....109

Operation and Auxiliary Materials..... 110

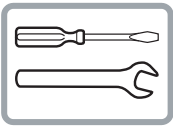

## FOREWORD

On receipt of your new **Steyr Motors Marine Engine**, the authorised dealer should have registered your engine at the Steyr Motors factory and reconfirmed this to you in the Operation, Maintenance and Warranty manual (chapter warranty / Warranty Registration Approval).

Future service requirements are indicated in this **SERVICE AND MAINTENANCE SCHEDULE**. When these services are carried out, the Steyr Motors Marine dealer will stamp the respective stubs. This servicing will assist in maintaining the value and satisfactory operation of your **Steyr Motors Marine Engine**.

It lies in the owner's interest that for maintaining warranty and best performance of his **Steyr Motors Marine Engine** he always insists on the sole utilization of **Steyr Motors - ORIGINAL** replacement parts, operational fluids and lubricants as well as Steyr Motors proved service procedures!

It is important that you study this booklet carefully as it will assist you in achieving satisfaction from your **Steyr Motors Marine Engine**. Please retain this manual in the boat as it **MUST** be presented to the **Steyr Motors Marine dealer** whenever you require **WARRANTY** and/or **SERVICE**.

## IMPORTANT NOTE

This manual contains all service activities required for your engine. Checks and maintenance for the other parts of a complete drive system still need to be completed. Any such procedures are to be found in separate, attached booklet(s) of the individual manufacturer's literature provided with the gearbox or similar drive components.

Whenever this manual refers to components like Manual Operation, Hydraulic Pump, etc., such instructions only apply where applicable since they are not used on every engine model.

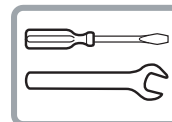

<b>MO Service- and Maintenance Schedule</b> (Z026167-0_04) (Series MO)			<i>daily</i>	<b>after first 50 hours or 6 months</b>	<b>every 150 h. or 12 months</b>	<b>every 300 h. or 24 months</b>	<b>notes</b>
<b>Engine Lubrication</b>	<i>check</i>	-for leakage	●				
		-oil level	●				
	<i>change</i>	-oil filter		●	●		
		-motor oil		●	●		
<b>Engine Cooling System</b>	<i>check</i>	-for leakage	●				
		-fluid level	●				
		-hoses, hose clamps	●				
		-antifreeze temperature condition		●	●		
	<i>change</i>	-antifreeze					every 24 months
<b>Raw Water System</b>	<i>check</i>	-hoses, hose clamps	●				
		-zinc anodes		●			periodically
		-raw water pump V-belt	●				
		-impeller			●		
	<i>clean</i>	-intercooler					every 750 hours or every 48 months
	<i>change</i>	-raw water pump V-belt			●		if required
		-impeller			●		if required
		-zinc anodes					if sacrificial progress reaches a material corrosion of 50%
<i>preserve</i>	- raw water circuit			●		after season	
<b>Raw Water Cooler (Oil - Fuel-Aux. Lubricant)</b>	<i>check</i>	-raw water passages			●		clean out deposits in pipelines
	<i>change</i>	-zinc anodes					if sacrificial progress reaches a material corrosion of 50%
<b>Air Filter</b>	<i>check</i>	-contamination	●				
	<i>change</i>	-air filter element				●	
	<i>preserve</i>	-					after season
<b>Fuel System</b>	<i>check</i>	-for leakage	●				
		-hoses		●	●		
		-prefilter		●	●		x <sub>1</sub>
	<i>change</i>	-fuel filters		●		●	
		-prefilter		●		●	x <sub>1</sub>
	<i>preserve</i>	-fuel system					after season
<b>Battery</b>	<i>battery</i>	-acid level		●	●		
		-density		●	●		
<b>Electronics</b>	<i>check</i>	-connections					after season
<b>Electrical Equipment</b>	<i>check</i>	-connections		●	●		tighten loose connections. Renew cables, if required
		-insulation		●	●		

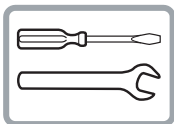

<b>MO Service- and Maintenance Schedule</b> (Z026167-0_04) (Series MO)			<i>daily</i>	<b>after first 50 hours or 6 months</b>	<b>every 150 h. or 12 months</b>	<b>every 300 h. or 24 months</b>	<b>notes</b>	
<b>Inversion Switch</b>	<i>check</i>	<i>-switch</i>			●			
	<i>change</i>	<i>-switch</i>					every 1500 hours or every 48 months	
<b>Driving System</b>	<i>re-center</i>	<i>-driving unit</i>		●	●		see manufacturers specifications	
<b>V-Belt For 6 cyl. models</b>	<i>check</i>	<i>-generator &amp; impeller pump</i>		●	●		adjust tension	
		<i>-power steering</i>		●	●		adjust tension	
	<i>change</i>	<i>-generator</i>				●	if required	
		<i>-power steering</i>				●	if required	
<b>Poly-V-Belt (Serpentine Belt) for 4 cyl. and 286, 306, 126, 156 models</b>  <b>Poly V-Belt Tensioner</b>	<i>check</i>	<i>-belt, pulleys and tight- eners for wear</i>		●	●			
	<i>change</i>	<i>-Poly-V-Belt</i>					every 1500 hours or every 48 months	
	<i>check</i>	<i>-</i>		●	●			
	<i>change</i>	<i>-</i>			●			
<b>Glow Plugs</b>	<i>change</i>	<i>-plugs</i>					every 1500 hours or every 48 months	
<b>Timing Belt</b>	<i>check</i>	<i>-belt tension</i>		●	●			
	<i>change</i>	<i>-timing belt</i>					every 1500 hours or every 48 months	
		<i>-idler pulley</i>						every 1500 hours or every 48 months
		<i>-water pump, tensioner</i>					every 1500 hours or every 48 months	
<b>Valves</b>	<i>check</i>	<i>-valve clearance</i>		●			every 750 hours or every 24 months	
<b>Engine Timing</b>	<i>check</i>	<i>-set timing</i>		●			every 750 hours or every 24 months	
<b>Unit Injector</b>	<i>check</i>	<i>-recalibrate levers setting</i>		●			every 750 hours or every 24 months	
		<i>-set point</i>		●			every 750 h. or every 24 months	
		<i>-tightening torques</i>		●			every 750 h. or every 24 months	
<b>Power steering pump or load sensing hydr. pump</b>	<i>check</i>	<i>-oil level</i>	●					
		<i>-for leakage</i>	●					
	<i>change</i>	<i>-hydraulic oil (ATF)</i>				●	every 750 h. or every 24 months	
<b>Gearbox- Sterndrive</b>	<i>check</i>	<i>-oil level</i>	●					
		<i>-for leakage</i>	●					
	<i>change</i>	<i>-gear oil (ATF)</i>						see manufactur- er's specification
		<i>-oil filter</i>						

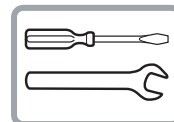

<b>MO Service- and Maintenance Schedule (Z026167-0_04) (Series MO)</b>			<i>daily</i>	<b>after first 50 hours or 6 months</b>	<b>every 150 h. or 12 months</b>	<b>every 300 h. or 24 months</b>	<b>notes</b>
<b>Front Vibration Damper</b>	<i>check</i>	<i>-tightening torque</i>		●		●	
<b>Engine Compartment and Bilge</b>	<i>check</i>	<i>-leakage water</i>	●				repair or consult your Steyr Motors Marine Dealer
		<i>-leakage fuel</i>	●				
		<i>-leakage exhaust gas</i>	●				
<b>Shifting</b>	<i>check</i>	<i>-smooth action</i>	●				if required, to be replaced by your Steyr Motors Marine Dealer
		<i>-adjustment</i>	●				
<b>Steering</b>	<i>check</i>	<i>-lubrication</i>	●				see Manufacturer's specification
		<i>-oil level</i>	●				
<b>Safety equipment</b>	<i>check</i>	<i>-remote control</i>	●				local rules and consultation of your Steyr Motors Marine Dealer
		<i>-emergency cutout</i>	●				
		<i>-completeness</i>	●				
		<i>-condition</i>	●				
	<i>change</i>	<i>-emergency cutout</i>					every 1500 hours or every 8 months
<b>Shaft Bearing Gland</b>	<i>check</i>	<i>-lubrication</i>	●				consult Steyr Motors Marine Dealer
		<i>-sealing</i>	●				
<b>Engine mount screws</b>	<i>check</i>	<i>-torque</i>		●			every 750 hours
<b>Warning Device</b>	<i>check</i>	<i>-function</i>		●	●		safety relevant

x<sub>1</sub> refer to manufacturer specification.

x<sub>1</sub> drain/clean water from separator bowl.

**NOTE:** Oil exchange interval must be adapted acc. application and utilisation of vehicle, respectively quality of engine lubricant in use.

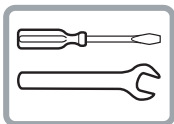

<b>SE Service- and Maintenance Schedule</b>				<i>daily</i>	after first 50 hours or 6 months	every 300 h. or 12 months	every 600 h. or 24 months	notes
Series SE 6 Cylinder (Z026168-0_10) (only for fuel according to EN 590)								
<b>Engine Lubrication</b>	<i>check</i>	- for leakage	O	●				
		- oil level	O	●				
	<i>change</i>	- oil filter	S		●	●		
		- engine oil	S		●	●		
<b>Engine Cooling System</b>	<i>check</i>	- for leakage	O	●				
		- fluid level	O	●				
		- hoses, hose clamps	O	●				
		- antifreeze temperature condition	O		●	●		
	<i>change</i>	- antifreeze	S					every 24 months
<b>Raw Water System</b>	<i>check</i>	- hoses, hose clamps	S	●				
		- zinc anodes	S		●			periodically
		- impeller	S			●		if required, change impeller
	<i>clean</i>	- intercooler	S					every 900 hours or every 48 months
	<i>change</i>	- zinc anodes	S					if sacrificial progress reaches a material corrosion of 50 %
	<i>preserve</i>	- raw water circuit	S			●		after season
<b>Raw Water Cooler (Fuel-Aux. Lubricant)</b>	<i>check</i>	- raw water passages	S			●		clean out deposits in pipelines
<b>Air Filter</b>	<i>check</i>	- contamination	S	●				
	<i>change</i>	- air filter element	S				●	
<b>Fuel System</b>	<i>check</i>	- for leakage	S	●				
		- hoses	S		●	●		
		- prefilter	S					$x_1$
		- water in fuel	S	●				$x_2$
	<i>change</i>	- fuel filters	S		●	●		depends on fuel quality
		- prefilter	S		●	●		$x_3$ , depends on fuel quality
<i>preserve</i>	- fuel system	S					after season / when out of operation for 6 months or more	
<b>Battery</b>	<i>check</i>		S					check battery charge condition
<b>Electronics</b>	<i>check</i>	- connections	S					after season
<b>Electrical Equipment</b>	<i>check</i>	- connections	S		●	●		tighten loose connections. Renew cables, if required
		- insulation	S		●	●		

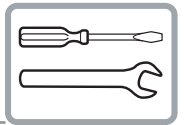

<b>SE Service- and Maintenance Schedule</b>					after first 50 hours or 6 months	every 300 h. or 12 months	every 600 h. or 24 months	notes
Series SE 6 Cylinder (Z026168-0_10) (only for fuel according to EN 590)				<i>daily</i>				
<b>Inversion Switch</b>	<i>check</i>	- switch	S			●		
	<i>change</i>	- switch	S					every 1800 hours or every 48 months
<b>Driving System</b>	<i>re-center</i>	- driving unit	S		●	●		x <sub>1</sub>
<b>Turbo charger</b>	<i>check</i>	- actuation	S			●		
	<i>lubricate</i>	-	S			●		
<b>Warning Device</b>	<i>check</i>	- function	S	●				safety relevant
<b>Engine Mount Screws</b>	<i>check</i>	- torque	S		●			every 900 hours
<b>Safety Equipment</b>	<i>check</i>	- remote control	S	●				local rules and consultation of your Steyr Motors dealer
		- emergency cutout	S	●				
		- completeness	S	●				
	<i>change</i>	- emergency cutout	S					every 1800 hours or every 48 month
<b>Poly-V-Belt</b>	<i>check</i>	- belt, pulleys and tighteners for wear	S		●	●		
	<i>change</i>	* poly-v-belt system with standard equipment e.g.: alternator, raw water pump and hydraulic pump	S					every 1800 hours or every 48 months
		** poly-v-belt system with optional equipment e.g. 2 <sup>nd</sup> additional alternator, high power hydraulic pump etc.	S					every 900 hours or every 48 months
<b>Poly-V-Belt Tensioner</b>	<i>check</i>	-	S		●	●		
<b>Glow Plugs</b>	<i>change</i>	- plugs	S					every 1800 hours or every 48 months
<b>Timing Belt</b>	<i>check</i>	- belt tension	S		●	●		
	<i>change</i>	- timing belt	S					every 1800 hours or every 48 months
		- idler pulley (2x pieces)	S					
		- water pump	S					every 3600 hours or every 48 months
		- idler pulley tensioner	S					
<b>Valves</b>	<i>check</i>	- valve clearance	S		●		●	
<b>Engine Timing</b>	<i>check</i>	- set timing	S		●		●	

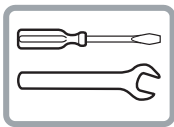

<b>SE Service- and Maintenance Schedule</b>								
Series SE 6 Cylinder (Z026168-0_10) (only for fuel according to EN 590)				<i>daily</i>	after first 50 hours or 6 months	every 300 h. or 12 months	every 600 h. or 24 months	notes
<b>Unit Injector</b>	<i>check</i>	- recalibrate levers setting	S		●		●	
		- set point	S		●		●	
		- tightening torques	S		●		●	
<b>Hydraulic Pump (if fitted)</b>	<i>check</i>	-oil level	S	●				
		-for leakage	S	●				
	<i>change</i>	- hydraulic oil	S				●	x <sub>1</sub>
<b>Torsional Coupler</b>	<i>check</i>	- tightness of bolts	S					every 48 months
	<i>change</i>	- bolts	S					if required, re- place bolts by us- ing Staloc 2S43
<b>Front Vibration Damper</b>	<i>check</i>	- tightening torque	S		●		●	
<b>Engine Compartment and Bilge</b>	<i>check</i>	- leakage water	S	●				repair or consult your Steyr Mo- tors dealer
		- leakage fuel	S	●				
		- leakage exhaust gas	S	●				
<b>Shifting</b>	<i>check</i>	- smooth action	S	●				
		- adjustment	S	●				
				O	for operator or operating personnel			
				S	for service personnel			

x<sub>1</sub> refer to manufacturer specification / as per manufacturers guidelines.

x<sub>2</sub> drain/clean water from separator bowl.

Water separator is mandatory; check water separator daily

**NOTE:** Water in fuel can lead to accelerated fuel aging and other severe problems which can cause clogged fuel system parts [esp. filters]

x<sub>3</sub> if no pre-filter-manufacturer specifications available: change after first 50 hours; then after every 300 hours or minimum every year

## NOTICE

Oil exchange interval must be adapted according to the application and utilization of the vessel, respectively to the quality of the engine lubricant in use. Operation at extreme environmental conditions may shorten the intervals. Any optical defect requires change of the component.

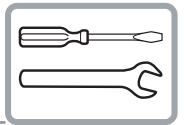

<b>SE Service- and Maintenance Schedule</b>									
Series SE 6 Cylinder (702117_01) (valid for engines equipped with kit fuel density and fuel <b>without</b> according to EN 590)				<i>daily</i>	after first 25 hours or 3 months	every 150 h. or 6 months	every 300 h. or 12 months	notes	
<b>Engine Lubrication</b>	<i>check</i>	- for leakage	O	●					
		- oil level	O	●					
	<i>change</i>	- oil filter	S		●	●			
		- engine oil	S		●	●			
<b>Engine Cooling System</b>	<i>check</i>	- for leakage	O	●					
		- fluid level	O	●					
		- hoses, hose clamps	O	●					
		- antifreeze temperature condition	O		●	●			
	<i>change</i>	- antifreeze	S					every 24 months	
<b>Raw Water System</b>	<i>check</i>	- hoses, hose clamps	S	●					
		- zinc anodes	S		●			periodically	
		- impeller	S			●			
	<i>clean</i>	- intercooler	S					every 900 hours or every 48 months	
	<i>change</i>	- impeller	S				●		if required
		- zinc anodes	S						if sacrificial progress reaches a material corrosion of 50%
<i>preserve</i>	- raw water circuit	S			●			after season	
<b>Raw Water Cooler (Fuel-Aux. Lubricant)</b>	<i>check</i>	- raw water passages	S			●		clean out deposits in pipelines	
<b>Air Filter</b>	<i>check</i>	- contamination	S	●					
	<i>change</i>	- air filter element	S				●		
<b>Fuel System</b>	<i>check</i>	- for leakage	S	●					
		- hoses	S		●	●			
		- prefilter	S					x <sub>1</sub>	
		- water in fuel	S					x <sub>2</sub>	
	<i>change</i>	- fuel filters	S		●	●			
		- prefilter	S		●	●		x <sub>3</sub>	
<i>preserve</i>	- fuel system	S					after season / when out of operation for 6 months or more		
<b>Battery</b>	<i>check</i>		S					check battery charge condition	
<b>Electronics</b>	<i>check</i>	- connections	S					after season	
<b>Electrical Equipment</b>	<i>check</i>	- connections	S		●	●		tighten loose connections. Renew cables, if required	
		- insulation	S		●	●			

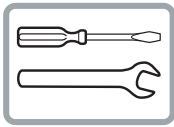

<b>SE Service- and Maintenance Schedule</b>					daily	after first 25 hours or 3 months	every 150 h. or 6 months	every 300 h. or 12 months	notes
Series SE 6 Cylinder (702117_01) (valid for engines equipped with kit fuel density and fuel <u>without</u> according to EN 590)									
<b>Inversion Switch</b>	check	- switch	S				●		
	change	- switch	S						every 1800 hours or every 48 months
<b>Driving System</b>	re-center	- driving unit	S		●		●		see manufacturers specifications
<b>Turbo Charger</b>	check	- actuation	S				●		
	lubricate	-	S				●		
<b>Warning Device</b>	check	- function	S	●					safety relevant
<b>Engine Mount Screws</b>	check	- torque	S		●				every 900 hours
<b>Safety Equipment</b>	check	- remote control	S	●					local rules and consultation of your Steyr Motors dealer
		- emergency cutout	S	●					
		- completeness	S	●					
	condition		S				●		
<b>Poly-V-Belt</b>	check	- belt, pulleys and tighteners for wear	S		●		●		
	change	* poly-v-belt system with standard equipment e.g.: alternator, raw water pump and hydraulic pump	S						every 1800 hours or every 48 months
** poly-v-belt system with optional equipment e.g.: 2 <sup>nd</sup> additional alternator, high power hydraulic pump etc.		S						every 900 hours or every 48 months	
<b>Poly-V-Belt Tensioner</b>	check	-	S		●		●		
<b>Glow Plugs</b>	change	- plugs	S						every 1800 hours or every 48 months
<b>Timing Belt</b>	check	- belt tension	S		●		●		
	change	- timing belt - idler pulley (2x pieces)	S						every 1800 hours or every 48 months
		- water pump - idler pulley tensioner	S						every 3600 hours or every 48 months
<b>Valves</b>	check	- valve clearance	S		●			●	
<b>Engine Timing</b>	check	- set timing	S		●			●	

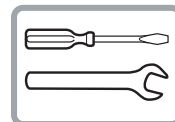

SE Service- and Maintenance Schedule					daily	after first 25 hours or 3 months	every 150 h. or 6 months	every 300 h. or 12 months	notes
Series SE 6 Cylinder (702117_01) (valid for engines equipped with kit fuel density and fuel <b>without</b> according to EN 590)									
<b>Unit Injector</b>	check	- recalibrate levers setting	S		●			●	
		- set point	S		●			●	
		- tightening torques	S		●			●	
<b>Hydraulic Pump (if fitted)</b>	check	- oil level	S	●					
		- for leakage	S	●					
	change	- hydraulic oil	S					●	x <sub>1</sub>
<b>Torsional Coupler</b>	check	- tightness of bolts	S						every 48 months
	change	- bolts	S						if required, replace bolts by using Staloc 2S43
<b>Front Vibration Damper</b>	check	- tightening torque	S		●			●	
<b>Engine Compartment and Bilge</b>	check	- leakage water	S	●					repair or consult your Steyr Motors dealer
		- leakage fuel	S	●					
		- leakage exhaust gas	S	●					
<b>Shifting</b>	check	- smooth action	S	●					
		- adjustment	S	●					
			O	for operator or operating personnel					
			S	for service personnel					

x<sub>1</sub> refer to manufacturer specification / as per manufacturers guidelines.

x<sub>2</sub> drain/clean water from separator bowl.

Water separator is mandatory; check water separator daily

**NOTE:** Water in fuel can lead to accelerated fuel aging and other severe problems which can cause clogged fuel system parts [esp. filters]

x<sub>3</sub> if no pre-filter-manufacturer specifications available: change after first 50 hours; then after every 300 hours or minimum every year

## NOTICE

Oil exchange interval must be adapted according to the application and utilization of the vessel, respectively to the quality of the engine lubricant in use. Operation at extreme environmental conditions may shorten the intervals. Any optical defect requires change of the component.

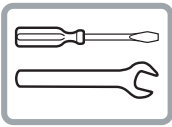

**Sticker of 1<sup>st</sup> preservation**  
(refer to Installation Manual P/N Z001139-0/  
Chapter 18/Installation and pre-delivery  
inspection report)

*Date:*

**Sticker of 2<sup>nd</sup> preservation**

*Date:*

**Sticker of 3<sup>rd</sup> preservation**

*Date:*

**Commissioning**

*Date:*

**50 h Service**

Made by:

*Date:*

**150 h Service**

Made by:

*Date:*

**300 h Service**

Made by:

*Date:*

**450 h Service**

Made by:

*Date:*

**600 h Service**

Made by:

*Date:*

**750 h Service**

Made by:

*Date:*

**900 h Service**

Made by:

*Date:*

**1050 h Service**

Made by:

*Date:*

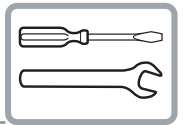

**1200 h Service**

Made by:

*Date:*

**1350 h Service**

Made by:

*Date:*

**1500 h Service**

Made by:

*Date:*

**1650 h Service**

Made by:

*Date:*

**1800 h Service**

Made by:

*Date:*

**1950 h Service**

Made by:

*Date:*

**2100 h Service**

Made by:

*Date:*

**2250 h Service**

Made by:

*Date:*

**2400 h Service**

Made by:

*Date:*

**2550 h Service**

Made by:

*Date:*

**2700 h Service**

Made by:

*Date:*

**2850 h Service**

Made by:

*Date:*

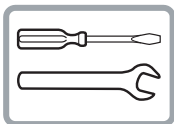



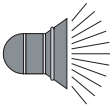



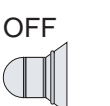

**Table - Error Indication on Instrument Panel**









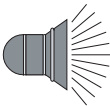

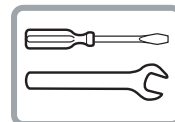

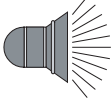







- A** audible warning device
- B** warning light - battery charge
- C** combined light preheating control & warning light engine oil pressure
- D** warning light check engine

**Operating condition:** During normale engine operation, or indication in case of sensor defect while ignition is switched ON.

**Event:** Speed resp. performance limitation during engine operation

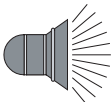
Indication status			Fault	Remarks
80° – 90 °C		OFF	<b>oil pressure below min. limit</b>	check oil level, contact authorized workshop
<b>ON</b>		<b>ON</b>		
		OFF		
80° – 90 °C		OFF	<b>fault oil pressure sensor or sensor connection</b>	check oil level, contact authorized workshop
OFF		<b>FLASHING (1x per sec.)</b>		
		OFF		
<b>ON</b>		ON	<b>engine overload during break-in period</b>	reduce throttle position until light goes OFF (indication during first 2 hours of operation) see “engine break in procedure”
				



Indication status			Fault	Remarks
80° – 90 °C <b>ON</b>  (2x per sec.)	 <b>FLASHING</b> (2x per sec.)	OFF	high exhaust temperature (over 80 °C) or defect exhaust temperature sensor or bad connection	check raw water system, strainer, impeller pump contact authorized workshop
	 OFF	OFF		
	 OFF	OFF		
high approx 108 °C <b>ON</b>  (2x per sec.)	 OFF	OFF	engine coolant temperature too high	after cooling down, check engine coolant level contact authorized workshop
	 OFF	OFF		
	 OFF	OFF		
120 °C <b>ON</b>  (2x per sec.)	 OFF	OFF	defect engine coolant sensor or bad connection	after cooling down, check engine coolant level contact authorized workshop
	 OFF	OFF		
	 OFF	OFF		
80° – 90 °C OFF 	 OFF	OFF	unstable idle speed, no indication on tachometer 	defect speed sensor or sensor connection contact authorized workshop
80° – 90 °C <b>ON</b>  (2x per sec.)	 <b>ON</b>	OFF	Trouble in governing loop, involved components: control solenoid, rack, control gear of unit injector, rack position sensor	contact authorized workshop
	 OFF	OFF		
	 OFF	OFF		

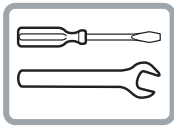



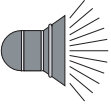







**Table - Error Indication on Instrument Panel (for SOLAS only)**











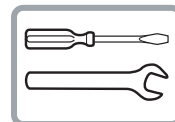

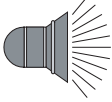



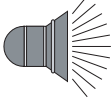

- A** audible warning device
- B** warning light - battery charge
- C** combined light preheating control & warning light engine oil pressure
- D** warning light check engine

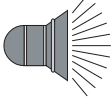
**Operating condition:** During normale engine operation, or indication in case of sensor defect while ignition is switched ON.

**Event:**  Speed resp. performance limitation during engine operation

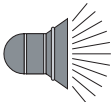
Indication status			Fault	Remarks
80° – 90 °C		OFF	oil pressure below min. limit	check oil level, contact authorized workshop
<b>ON</b>		ON		
		OFF		
80° – 90 °C		OFF	fault oil pressure sensor or sensor connection	check oil level, contact authorized workshop
OFF		<b>FLASHING</b> (1x per sec.)		
		OFF		
<b>ON</b>		ON	engine overload during break-in period	reduce throttle position until light goes OFF (indication during first 2 hours of operation) see “engine break in procedure”
				



Indication status			Fault	Remarks
80° – 90 °C <b>ON</b>  <i>(2x per sec.)</i>	 <b>FLASHING</b> <i>(2x per sec.)</i>	OFF	high exhaust temperature (over 80 °C) or defect exhaust temperature sensor or bad connection	check raw water system, strainer, impeller pump contact authorized workshop
	 OFF	OFF		
	 OFF	OFF		
high approx 105 °C <b>ON</b>  <i>(2x per sec.)</i>	 OFF	OFF	engine coolant temperature too high	after cooling down, check engine coolant level contact authorized workshop
	 OFF	OFF		
	 OFF	OFF		
120 °C <b>ON</b>  <i>(2x per sec.)</i>	 OFF	OFF	defect engine coolant sensor or bad connection	after cooling down, check engine coolant level contact authorized workshop
	 OFF	OFF		
	 OFF	OFF		
80° – 90 °C <b>ON</b> 	 <b>ON</b>	OFF	Trouble in governing loop, involved components: control solenoid, rack, control gear of unit injector, rack position sensor	contact authorized workshop
	 OFF	OFF		
	 OFF	OFF		

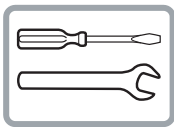

## Principle service code list "SE" engines

**NOTE:** Some codes may not apply due to different application!

DTC List / Error Code List - SE Engines V50000.11 Version 4						
Dec.	Hex.	ABBREV.	INVOLVED DEVICE	POSSIBLE CAUSE	Variable	Limits
70	46	VTGHBRIDGE_E-FER	Turbocharger output control	functional error on ECU-H-Bridge		
71	47	VTGHBRIDGE_E-MIN	Turbocharger output control	signal voltage too low, possible short circuit to ground (X25)		
72	48	VTGHBRIDGE_E-MAX	Turbocharger output control	signal voltage too high, possible short circuit to battery (X25)		
263	107	BARO_FP_E-MIN	Barometric Pressure Sensor	signal voltage too low, possible short circuit to ground	AdcCountBARO_u16	20 cnts 0,098 V
264	108	BARO_FP_E-MAX	Barometric Pressure Sensor	signal voltage too high, possible short circuit to battery		1000 cnts 4,888 V
274	112	ACT_E-MIN	Air Charge Temperature Sensor	signal voltage too low, possible short circuit to ground	AdcCountACT_u16	50 cnts 0,244 V
275	113	ACT_E-MAX	Air Charge Temperature Sensor	signal voltage too high, possible short circuit to battery (B7)		1007 cnts 4,922 V
279	117	ECT_E-MIN	Engine Coolant Temperature Sensor	signal voltage too low, possible short circuit to ground	AdcCountECT_u16	22 cnts 0,108 V
280	118	ECT_E-MAX	Engine Coolant Temperature Sensor	signal voltage too high, possible short circuit to battery (B6)		1000 cnts 4,888 V
288	120	PED_E-NPL	Potentiometer accelerator 1 & 2	Possibly wrong pedal used (B9)	PED 1 + 2	≠ 5 V
290	122	PED1_E-MIN	Potentiometer accelerator 1	signal voltage too low, possible short circuit to ground	AdcCountPED1_u16	20 cnts 0,098 V
291	123	PED1_E-MAX	Potentiometer accelerator 1	signal voltage too high, possible short circuit to battery (B9)		950 cnts 4,643 V
374	176	FUEL_DENSITY_E-NPL	Fuel density sensor	Fuel Density value out of range		> 1160 kg/m <sup>3</sup> or < 480 kg/m <sup>3</sup>
375	177	FUEL_DENSITY_E-FER	Fuel density sensor	Timeout of fuel density sensor - check connection and sensor		no signal for 90s
395	18B	PF20_RANGE_E-FER	PF20 - Fuel Pressure Sensor	fuel pressure is below the limit		< 2 bar for 10s
396	18C	PF20_E-MIN	PF20 - Fuel Pressure Sensor	signal voltage too low, possible short circuit to ground	AdcCountPF20_u16	20 cnts 0,098 V
397	18D	PF20_E-MAX	PF20 - Fuel Pressure Sensor	signal voltage too high, possible short circuit to battery (B10)		1000,5 cnts 4,890 V
544	220	REM_PAD_E-SIG	Remote Pedal	time out of can message received from remote accelerator pedal		

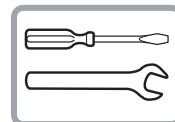

## Principle service code list "SE" engines

**NOTE:** Some codes may not apply due to different application!

DTC List / Error Code List - SE Engines V50000.11							Version 4	
Dec.	Hex.	ABBREV.	INVOLVED DEVICE	POSSIBLE CAUSE	Variable	Limits		
545	221	REM_PAD_E-NPL	Remote Pedal	input signal out of valid range				
546	222	PED2_E-MIN	Potentiometer accelerator 2	signal voltage too low, possible short circuit to ground	AdcCountPED2_u16	20 cnts	0,098 V	
547	223	PED2_E-MAX	Potentiometer accelerator 2	signal voltage too high, possible short circuit to battery (B9)		1000 cnts	4,888 V	
594	252	FMS_MALF_E-SIG	Fuel Metering Solenoid	FMS malfunction error detected				
595	253	FMS_E-MIN	Fuel Metering Solenoid	rack calibration position is below the minimum SRPOS value (Y1)		<30/>135 cnts		
596	254	FMS_E-MAX	Fuel Metering Solenoid	rack calibration position is beyond the maximum SRPOS value		<894/>999 cnts		
600	258	RPOS_E-MAX	Rack Position Sensor	signal voltage too high, possible short circuit to battery (B1)	AdcCountRPOS_u16	1020 cnts	4,985 V	
601	259	RPOS_E-MIN	Rack Position Sensor	signal voltage too low, possible short circuit to ground		24 cnts	0,117 V	
899	383	TLE_OUTL2_GPR_E-MIN	Glow Plug RELAY	signal voltage too low, possible short circuit to ground				
900	384	TLE_OUTL2_GPR_E-MAX	Glow Plug RELAY	signal voltage too high, possible short circuit to battery (K3)				
1029	405	EXT_E-MIN	Exhaust Temperature Sensor	signal voltage too low, possible short circuit to ground	AdcCountEXT_u16	22 cnts	0,108 V	
1030	406	EXT_E-MAX	Exhaust Temperature Sensor	signal voltage too high, possible short circuit to battery (B8)		1000cnts	4,888 V	
1314	522	LPS_E-MIN	Lubricant Pressure Sensor	signal voltage too low, possible short circuit to ground	AdcCountLPS_u16	20 cnts		
1315	523	LPS_E-MAX	Lubricant Pressure Sensor	signal voltage too high, possible short circuit to battery (B5)		1000 cnts	4,888 V	
1349	545	T30_E-MIN	T30 Exhaust Temperature Sensor	signal voltage too low, possible short circuit to ground		50 cnts	0,25V	
1350	546	T30_E-MAX	T30 Exhaust Temperature Sensor	signal voltage too high, possible short circuit to battery (X21.1)		700 cnts	3,421V	

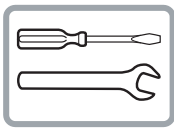

**Principle service code list "SE" engines**

**NOTE:** Some codes may not apply due to different application!

DTC List / Error Code List - SE Engines V50000.11 Version 4							
Dec.	Hex.	ABBREV.	INVOLVED DEVICE	POSSIBLE CAUSE	Variable	Limits	
1378	562	VBATTIN_E-MIN	Battery Voltage De-tection Sensor	Battery voltage is too low			
1379	563	VBATTIN_E-MAX	Battery Voltage De-tection Sensor	Battery voltage is too high			
1540	604	RAMECC_E-FER	ECU	error on ECU RAM, re- place ECU with new one			
1576	628	TLE_RL1_FPR_E-MIN	Fuel Pump Relay Output	signal voltage too low, possible short circuit to ground			
1577	629	TLE_RL1_FPR_E-MAX	Fuel Pump Relay Output	signal voltage too high, possible short circuit to battery (K2)			
1581	62D	FMS_E-FER	Fuel Metering Sole- noid	rack is not calibrated yet			
1592	638	FMS_E-SIG	Fuel Metering Sole- noid	non plausible signal from fms			
1602	642	VREF1_E-MIN	VREF1 Sensor	signal voltage too low, possible short circuit to ground	AdcCountVRef1_ u16	20 cnts	0,098 V
1603	643	VREF1_E-MAX	VREF1 Sensor	signal voltage too high, possible short circuit to battery		1000 cnts	4,888 V
1618	652	VREF2_E-MIN	VREF2 Sensor	signal voltage too low, possible short circuit to ground	AdcCountVRef2_ u16	20 cnts	0,098 V
1619	653	VREF2_E-MAX	VREF2 Sensor	signal voltage too high, possible short circuit to battery		1000 cnts	4,888 V
1688	698	VREF3_E-MIN	VREF3 Sensor	signal voltage too low, possible short circuit to ground	AdcCountVRef3_ u16	20 cnts	0,098 V
1689	699	VREF3_E-MAX	VREF3 Sensor	signal voltage too high, possible short circuit to battery		1000 cnts	4,888 V
1796	704	HYB_CLUTCH_E-FER	Hybrid Transmission Clutch	clutch is not engaged right			
1829	725	RPM_PRECRANK_E- FER	RPM Sensor / Starter	RPM signal not OK during start or functional error on starter			
1831	727	FM_FP_RPM_SIG_E- E-SIG	RPM Sensor	RPM Sensor defect, signal voltage not correct, wiring not ok			

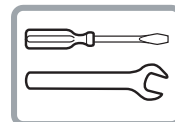

## Principle service code list "SE" engines

**NOTE:** Some codes may not apply due to different application!

DTC List / Error Code List - SE Engines V50000.11							Version 4	
Dec.	Hex.	ABBREV.	INVOLVED DEVICE	POSSIBLE CAUSE	Variable	Limits		
2586	A1A	HCU_ERROR_E-FER	Hybrid Control Unit	functional error on HCU				
2673	A71	HCU_OVERLOAD_E-FER	Hybrid Control Unit	too high voltage on HCU				
2684	A7C	HCU_OVERTEMP_E-FER	Hybrid Control Unit	Over temperature on HCU				
4097	1001	ITP_E-MIN	Injection Timing Device Position Sensor	signal voltage too low, possible short circuit to ground	AdcCountITP_u16	20 cnts	0,098 V	
4098	1002	ITP_E-MAX	Injection Timing Device Position Sensor	signal voltage too high, possible short circuit to battery (B2)		1000 cnts	4,888 V	
4112	1010	ITD_INVCALIB_E-FER	Injection Timing Device	invalid calibration value, recalibrate the ITD		<15/>200 cnts		
4113	1011	ITD_FP_E-FER	Injection Timing Device	ITD is possibly not moving (Y2)		ITP deviation > 3°for min.		
4181	1055	T30FB_E-MIN	T30 feedback	feedback current error	AdcCountT30Fb_u16			
4182	1056	T30FB_E-MAX	T30 Exhaust Temperature Sensor	Invalid signal level				
8191	1FFF	FAULPATH-FER	ECU faults	unexpected error detected				
8744	2228	MAP_E-MIN	Manifold Air Pressure Sensor (Boost pressure Sensor)	signal voltage too low, possible short circuit to ground	AdcCountMAP_u16	150 cnts	0,733 V	
8745	2229	MAP_E-MAX	Manifold Air Pressure Sensor (Boost pressure Sensor)	signal voltage too high, possible short circuit to battery (B4)		980 cnts	4,790 V	
8805	2265	WIF_E-FER	Water in fuel sensor	There's too much water in the water separator. Service required		level too high for min. 3s *		
9572	2564	VTGPOSFB_E-MIN	Turbocharger Position Feedback	signal voltage too low, possible short circuit to ground (X25)	AdcCountVTG-POS_u16			
9573	2565	VTGPOSFB_E-MAX	Turbocharger Position Feedback	signal voltage too high, possible short circuit to battery (X25)				
49811	C293	HCU_OFFLINE_E-FER	Hybrid Control Unit	HCU is offline, or connection is broken				

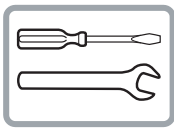

## Principle failure code list "MO" engines

**NOTE:** Some codes may not apply due to different application!

CODE	ABBREV.	REFER TO CIRCUIT	INVOLVED DEVICE	POSSIBLE CAUSE
12	Control code			this code is designated for beginning or end of loop
13	LoMap	X12/B12	boost pressure sensor	signal level too low (short circuit or missing contact)
14	HiMap	X12/B12	boost pressure sensor	signal level too high (missing connection)
17	LoEXH	X17/B17	air charge temp. sensor	signal level too low (short circuit or missing contact)
18	HiEXH	X17/B17	air charge temp. sensor	signal level too high (missing connection)
21	LoECT	X16/B16	water temp. sensor	signal level too low (short circuit or missing contact)
22	HiECT	X16/B16	water temp. sensor	signal level too high (missing connection)
23	LoPed1	X13/B13	potentiometer accelerator	signal level entry too low
24	HiPed1	X13/B13	potentiometer accelerator	signal level entry too high
25	LoVPWR	F5/K27	main relay	low voltage supply to ECU, F5, K27
26	HiVPWR	F5/K27	main relay	too high voltage on VPROT input
27	LoVREF	X5/Z3	module, connector	too low voltage on sensor supply, possible short circuit
28	HiVREF	X5/Z1	module, connector	too high voltage on sensor supply
29	PedS	X13/B13	accelerator potentiometer	defect on pedal safety switch, pin 1-2
31	LoLPS	X18/B18	lubricant pressure sensor	signal level too low (short circuit or missing contact)
32	HiLPS	X18/B18	lubricant pressure sensor	signal level too high (missing connection)
33	LoPed2	X13/B13	potentiometer accelerator	signal level too low
34	HiPed2	X13/B13	potentiometer accelerator	signal level too high (missing connection)
35	LoRPos	X14/B14	rack position potentiometer	signal level too low (short circuit or missing contact)
36	HiRPos	X14/B14	rack position potentiometer	signal level too high (missing connection)
37	LoLOP	X18/B18	lubricant pressure sensor	signal level too low (short circuit)
38	HiLOP	X18/B18	lubricant pressure sensor	signal level too high (missing connection)
53	N_RFI	X15/B15	RPM-sensor	radio interference / sensor input
54	BadSta	M1-Pin50	K28 start assist relay	no start signal from assist solenoid
55	NoPuls	X15/B15	RPM-sensor	no speed signal during crank

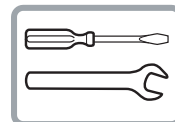

## Principle failure code list "MO" engines

**NOTE:** Some codes may not apply due to different application!

CODE	ABBREV.	REFER TO CIRCUIT	INVOLVED DEVICE	POSSIBLE CAUSE
56	Srpos	Y14(B14)	refer to setting rack pos.	rack calibration bad/rack position outside tolerance field
57	Rack0	Y14(B14)	refer to setting rack pos.	bad rack zero position
99	FMSpwm	X20/Y20	actuator / solenoid	defect in governor solenoid wire circuit (Y20, main relay K27-no frequency sent or governor solenoid circuit connected)
161	HiVTGc	Y28	REA unit at turbo charger	defect in circuit of actuator turbo charger (short circuit)
162	LoVTGc	Y28	REA unit at turbo charger	defect in circuit of actuator turbo charger (missing connection)
164	CELS	L2	check engine lamp	Current limit exceeded (short circuit)
165	CELo	L2	check engine lamp	missing connection or bulb blown
167	FPR_s	K24	fuel pump relay	Current limit exceeded in relay circuit (short circuit)
168	FPR_o	K24	fuel pump relay	no current detected in relay circuit (disconnection)
177	MR_s	K27	main relay	no current detected in main relay circuit (short circuit)
178	MR_o	K27	main relay	no current detected in main relay circuit (disconnection)
181	WarnLs	L3	oil pressure lamp	Current limit exceeded (short circuit)
182	WarnLo	L3	oil pressure lamp	no current in circuit of oil pressure lamp
186	BadPos	Y20	governor solenoid	Nominal-actual value difference (rack pos. error, rack jammed)
187	HiFMSC	X20/X20	governor solenoid	defect in governor wire circuit (resistance too high)
188	LoFMSc	X20	governor solenoid	(bulb blown or missing connection) defect in governor wire circuit (resistance too low)
193	VTG_Bad	Y28	REA unit at turbo charger	defect in output circuit (short circuit or missing connection)
194	GPR_s	K26	glow assist relay	current limit exceeded in glow plug relay circuit (short circuit)
195	GPR_o	K26	glow assist relay	no current detected in glow plug relay circuit (disconnection)
201	HiTEMP	--	operation limit exceeded -	engine was operated with too high coolant temperature
202	Lop	--	operation limit exceeded - engine overheated	engine was operated with too low lubricant pressure
203	Manop	--	operation limit exceeded - lubricant pressure too low	engine operated with manual movement of rack

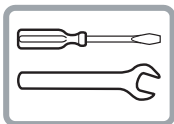

## Trouble Check Chart

**ATTENTION:**



After following the “Action” described in chart, and before cranking the engine, make sure there are no loose fuel connections. Make sure engine compartment is free of fuel vapours. Failure to do so could result in fire.

SYMPTOM	POSSIBLE CAUSE	ACTION
Engine won't start	<ol style="list-style-type: none"> <li>1. No fuel in tank or shut-off valve closed</li> <li>2. Air leak in suction lines</li> <li>3. Fuel line plugged or pump defective</li> <li>4. Poor fuel quality</li> <li>5. Water in fuel filter</li> <li>6. System error or failure</li> <li>7. Battery output insufficient</li> </ol>	<p>Fill tank or open valve.</p> <p>Bleed fuel system and check for leaks.</p> <p>Fuel pump may be defective. See your Steyr Motors Marine dealer.</p> <p>Replace fuel.</p> <p>Replace or drain water from fuel filter. Check fuel supply for water contamination. If water is present, drain fuel tank and flush with fresh fuel.</p> <p>Check Engine Management System display for service code.</p> <p>Charge or replace battery.</p>
Only for SOLAS ==>	<ol style="list-style-type: none"> <li>8. Inversion switch actuated</li> </ol>	<p>Cancelled by ignition “OFF - ON”</p>
Starter won't crank engine	<ol style="list-style-type: none"> <li>1. Battery connections loose or corroded</li> <li>2. Battery is dead</li> <li>3. Starter connections loose</li> <li>4. Ignition switch</li> <li>5. Fuse blown on panel</li> <li>6. Starter auxiliary relay</li> </ol>	<p>Check for loose connections and corrosion. Clean connections and tighten.</p> <p>Check level of electrolyte and charge battery.</p> <p>Check connections and tighten. If solenoid clicks when attempting to start engine, see your Steyr Motors Marine dealer.</p> <p>If inoperative, see your Steyr Motors Marine dealer.</p> <p>Check and replace if defect.</p> <p>Check terminal connection and function of relay.</p>
Engine runs erratically	<ol style="list-style-type: none"> <li>1. Water, air and/or dirt in fuel filter</li> <li>2. Anti-siphon valve stuck</li> <li>3. Fuel pump</li> </ol>	<p>Replace filter. Inspect fuel supply line.</p> <p>Clean and inspect or replace. (Tank)</p> <p>Check operation of pump. Replace fuel pump. See your Steyr Motors Marine dealer.</p>

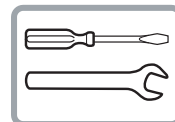

**Trouble Check Chart**

SYMPTOM	POSSIBLE CAUSE	ACTION
Engine vibrates	<p>Propeller condition</p> <p>Unit injector</p>	<p>Check for bent, broken, or damaged propeller. Check for weeds on propeller or sterndrive gearcase. Check for bent propeller shaft.</p> <p>See your Steyr Motors Marine dealer.</p>
Engine runs but boat makes little or no progress	Fouled propeller etc.	<p>Check:</p> <ol style="list-style-type: none"> <li>1. Propeller for weeds, remove as required.</li> <li>2. Propeller for spun hub, repair or replace.</li> <li>3. Hull for excessive marine growth, clean as required.</li> </ol>
Performance loss	<ol style="list-style-type: none"> <li>1. System error or failure</li> <li>2. Boat overloaded</li> <li>3. Boat trim</li> <li>4. Excessive water in bilge</li> <li>5. Boat hull condition</li> <li>6. Improper propeller selection</li> <li>7. Fuel incorrect</li> <li>8. Throttle not fully open</li> <li>9. Overheating</li> <li>10. Air intake troubles</li> </ol>	<p>Check: using diagnostics for errors or limitations. Engine coolant temperature; audible and or visual alarms.</p> <p>Reduce load.</p> <p>Distribute boat load evenly. Adjust trim.</p> <p>Drain bilge.</p> <p>See your Steyr Motors Marine dealer.</p> <p>Select proper propeller pitch and diameter.</p> <p>Fill tank with correct fuel. Check fuel filter and fuel flow condition.</p> <p>Check throttle command lever for full travel.</p> <p>Check cooling system. Remove debris from water intake. Check belt tension.</p> <p>Check condition of impeller.</p> <p>Check for clogged heat exchanger tubing (in raw water circuit).</p> <p>Check intake air filter.</p> <p>Check ventilation of engine compartment.</p>
Excessive free play in steering wheel	Steering cable loose	See your Steyr Motors Marine dealer.
High shift effort	<ol style="list-style-type: none"> <li>1. Remote control or transom bracket shift cable</li> <li>2. Remote control binding</li> <li>3. Engine/drive mechanism binding</li> </ol>	<p>Replace and adjust.</p> <p>See your Steyr Motors Marine dealer.</p> <p>See your Steyr Motors Marine dealer.</p> <p>See your Steyr Motors Marine dealer.</p>

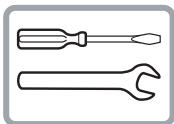

## Wiring harness 4-cylinder "MO" engines

Designation	Component	Description
A5	E-Box	control unit
F1	fuse 50 A	main fuse
F2	fuse 50 A	glow plugs
F3	fuse 50 A	glow plugs
F4	fuse 5 A	permanent current modul and K27
F5	fuse 10 A	switched current for module (K27)
F6	fuse 10 A	fuel pump (K24)
F7	fuse 10 A	preheating – control circuit
G1	alternator	
G2	battery	to be provided by customer
J1	plug 23-pole	connection engine cable – instrument cable
K24	relay	fuel pump
K26-1	relay	preheating – control circuit
K26-2	relay	preheating – load circuit
K27	relay	main circuit
K28	relay	start
M1	starter	
M2	fuel pump	
R10	glow pins	
X2 (S2)	plug 2-pole	gears switch
X3 (S3)	plug 2-pole	inversion switch (only SOLAS)
X5 (A5)	plug 35-pole	module
X12 (B12)	plug 3-pole	boost-pressure senso
X13 (B13)	plug 5-pole	potentiometer accelerator
X14 (B14)	plug 3-pole	rack position sensor
X15 (B15)	plug 3-pole	engine speed sensor
X16 (B16)	plug 2-pole	engine temperature senso
X17 (B17)	plug 2-pole	exhaust gas temperature senso
X18 (B18)	plug 3-pole	oil pressure sensor
X19 (B19)	plug 1-pole	oil pressure gauge (optional)
X20 (Y20)	plug 2-pole	control solenoid
X22 (B22)	without stop	trim sensor (optional)
X23	plug 6-pole	diagnosis
X26 (Y26)	plug 2-pole	disconnection blow-by (only SOLAS)
Z1	splice spot	earth connection sensor
Z2	splice spot	earth connection (31) on engine
Z3	splice spot	ensor supply +5 V
Z4	splice spot	earth connection (31) on E-box plate
Z6	splice spot	shield speed sensor line

### Cable numbers/principal functions:

15000-xx	ignition – positive (from ignition switch)	31100-xx	Do not connect mass for sensors with battery negative!
15012-xx	+12 volt via main relay and modulator unit A5	601xx-01	Sensor signal to modulator unit A5 and/ or instruments.
15100-xx	+5 volt supply voltage for sensors	606xx-01	Exit from modulator unit A5 to display system (tachometer, temperature dis- play, ...)
30000-xx	battery-positive (not secured)		
30012-xx	battery-positive (secured)		
31000-xx	battery negative (GND)		











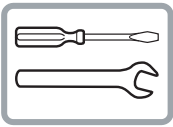

**Wiring diagram MO E-Box external, 2-pol, 4-cyl.**

(from engine s.n. 482330250)

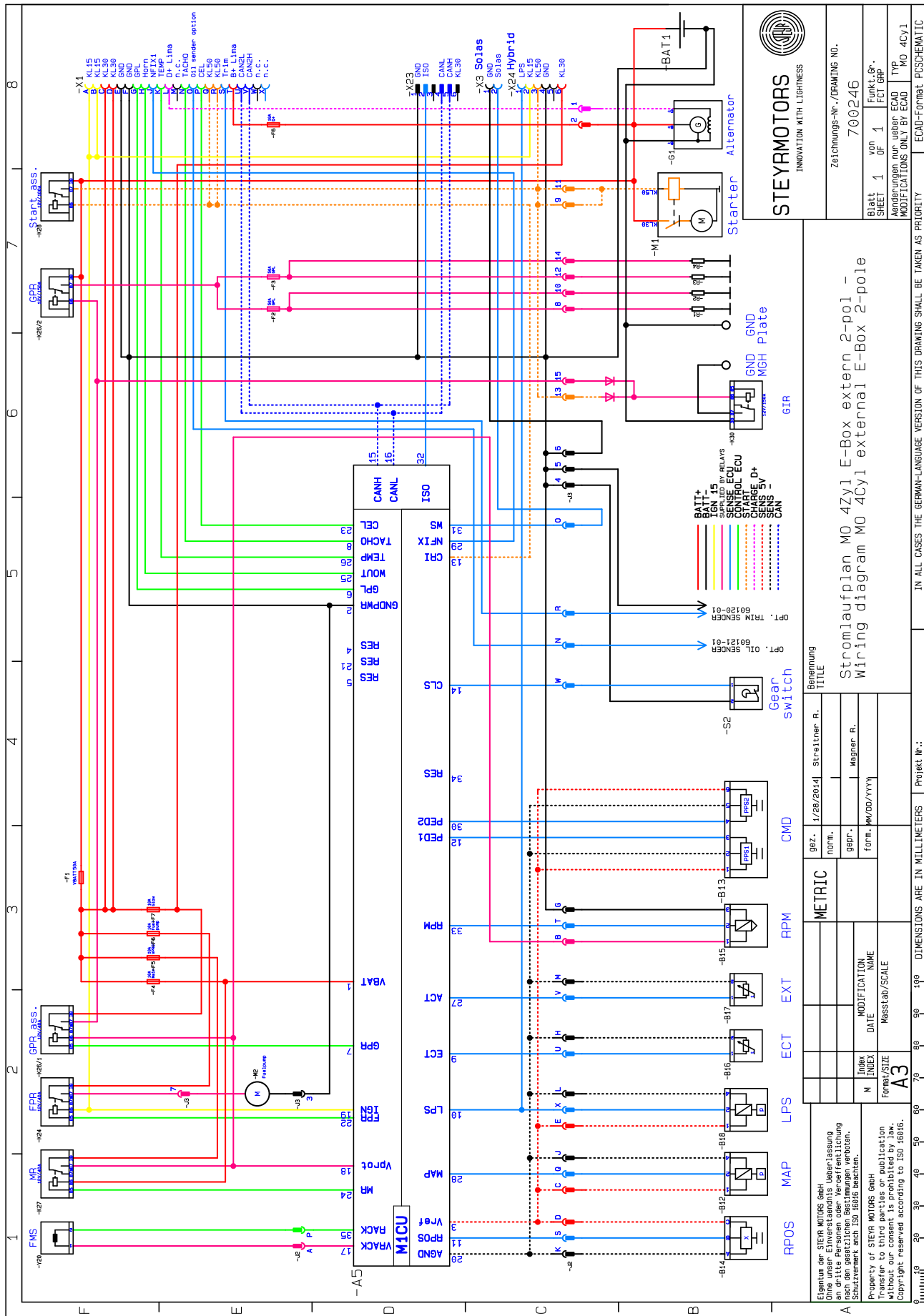

**STEYRMOTORS**  
INNOVATION WITH LIGHTNESS

Zeichnungs-Nr./DRAWING NO. 700246

Blatt 1 von 1 Funkt.-Gr. 1  
SHEET 1 OF 1 FCT GRP

Änderungen nur über ECAD TYP  
MODIFICATIONS ONLY BY ECAD MO 4Cy1

Strömlaufplan MO 4Zyl E-Box extern 2-pol - Wiring diagram MO 4Cyl external E-Box 2-pole	
gezm. 1/28/2014 Streifner R.	gezm. Wagner R.
METRIC	Form. MW/SD/YYYY
Index M	Modification DATE
Format/SCALE A3	Masstab/SCALE
DIMENSIONS ARE IN MILLIMETERS Projekt Nr.:	

Eigentum der STEYR MOTORS GmbH  
 Ohne unser Einverständnis Überlassung  
 an dritte Personen oder Veröffentlichung  
 nach den gesetzlichen Bestimmungen verboten.  
 Schutzmarken sind SP 2500 beschriftet.

Property of STEYR MOTORS GmbH  
 Transfer to third parties or publication  
 without our consent is prohibited by  
 law. Copyright reserved according to ISO 9001:2015.



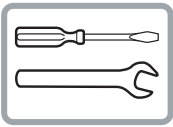

# Wiring diagram MO 12 V, 2 pol, 6-cyl.

(until engine s.n. 482330250)



**STEYRMOTORS**  
INNOVATION WITH LIGHTNESS

## WIRING DIAGRAM / MARINE - 4/6 CYLINDER - 2-POLE - 12V (OPTION)

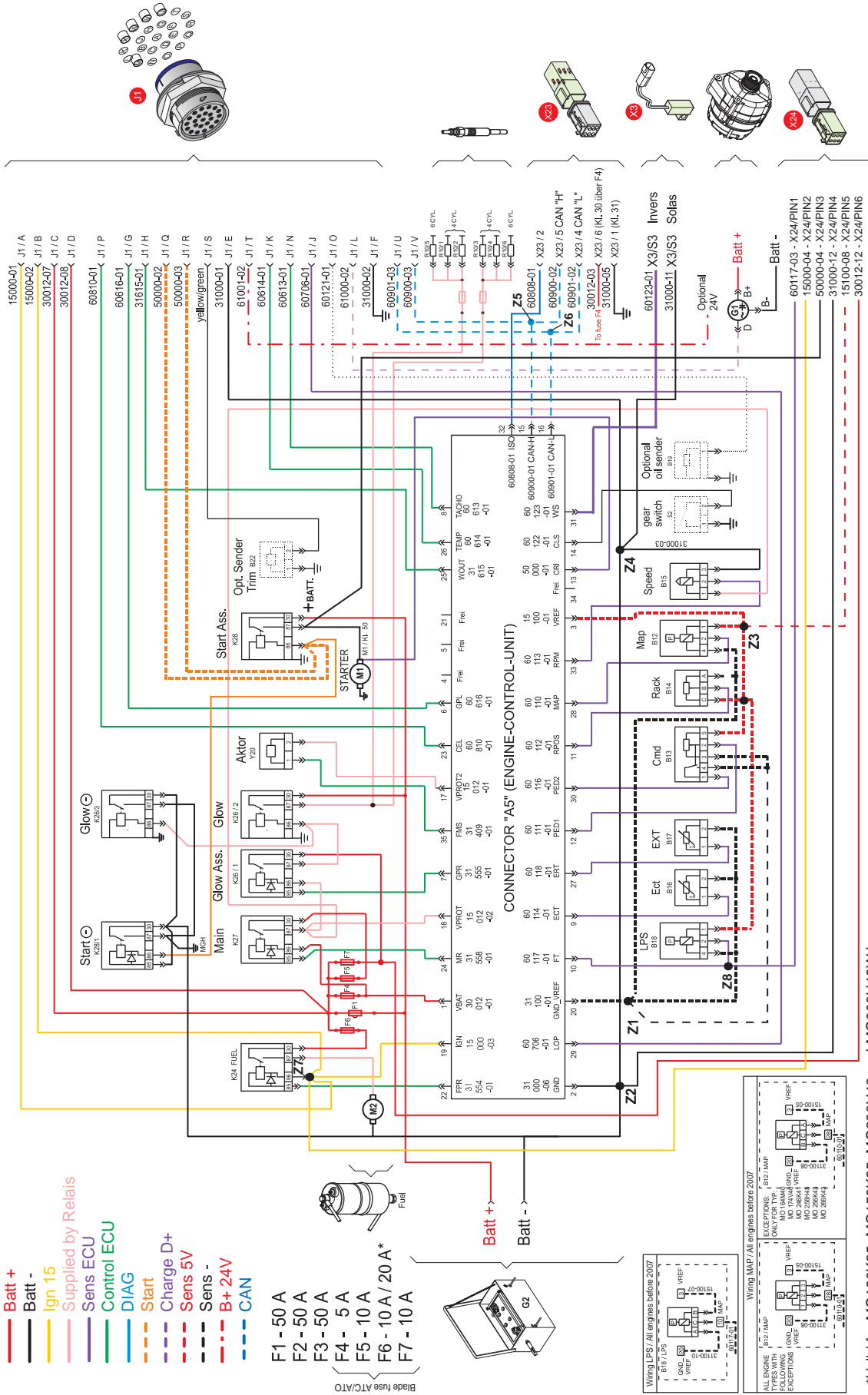

2179350-0\_05\_161007

www.steyr-motors.com

\*Valid for MO126K25, MO286H43 and MO306H43WJ

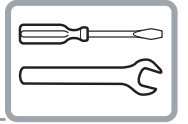

Wiring diagram MO 24 V, 2 pol, 6-cyl.

(until engine s.n. 482330250)



**WIRING DIAGRAM / MARINE - 4/6 CYLINDER - 2-POLE - 24V COMPLETE SYSTEM**

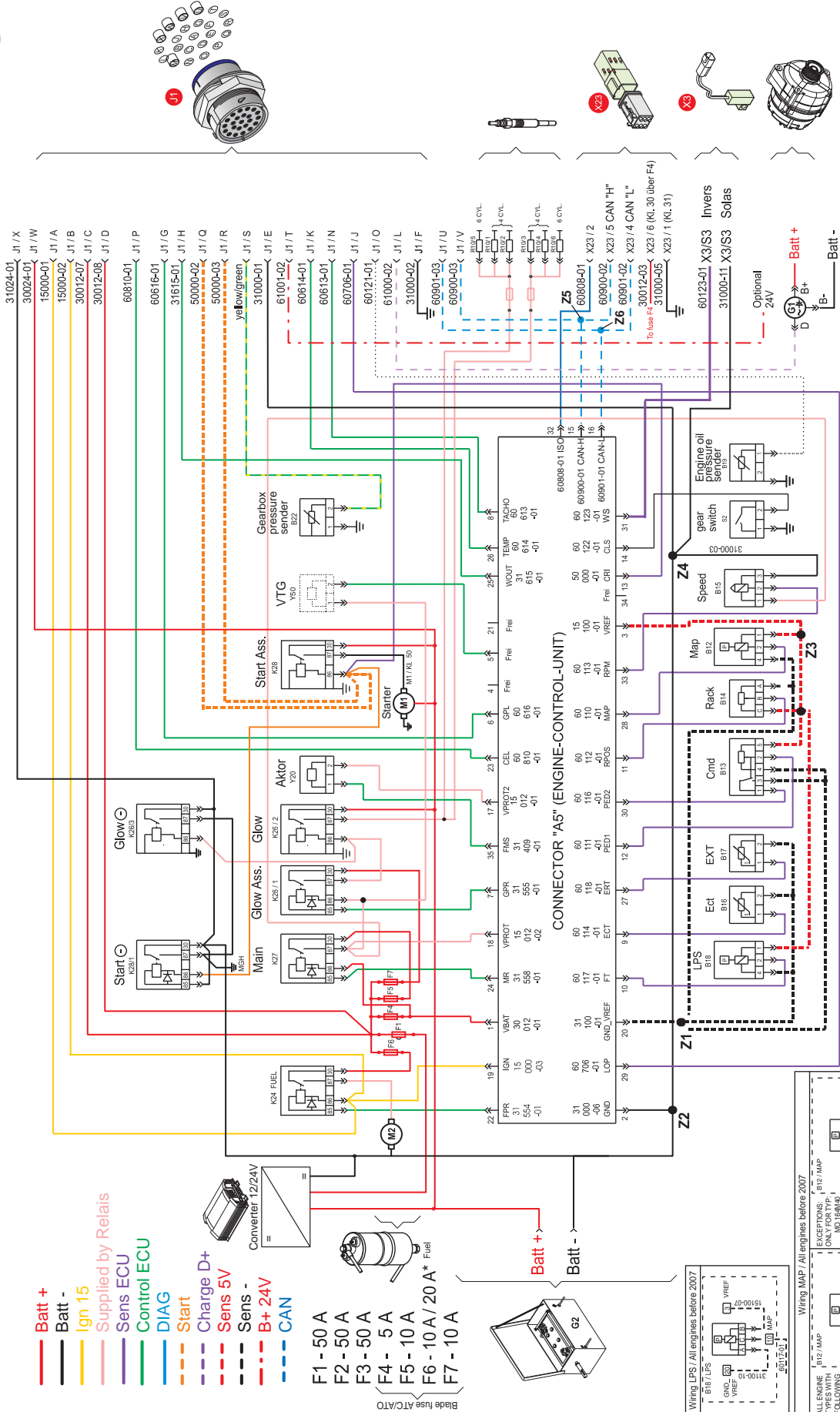

- Batt +
- Batt -
- Ign 15
- Supplied by Relais
- Sens ECU
- Control ECU
- DIAG
- Start
- Charge D+
- - - Sens 5V
- - - Sens -
- - - B+ 24V
- - - CAN

- F1 - 50 A
- F2 - 50 A
- F3 - 50 A
- F4 - 5 A
- F5 - 10 A
- F6 - 10 A / 20 A \* Fuel
- F7 - 10 A

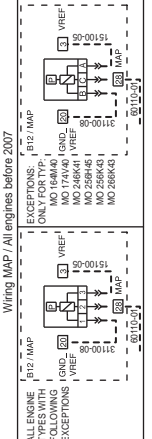
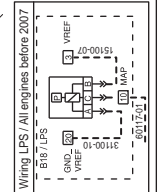
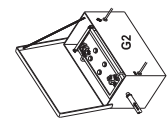

\*Valid for MO126K25, MO156K25, MO286H43 and MO306H43W

www.steyr-motors.com

2179729-D\_02\_161007

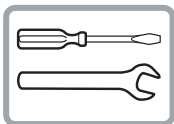

**Description - Wiring harness instrument panels 4 cyl. marine engines**

Designation	Component	Description
F9	fuse 10 A	
J1	23-pin plug	connection engine cable – instrument cable
S1	switch	ignition (red)
S2	switch	start (green)
S3	switch	emergency cut off (orange)
S7	switch	key switch constant revolution (optional)
L1	lamp	charge control
L2	lamp	cel – check engine lamp
L3	lamp	oil pressure/preheating control
P1	gauge	engine coolant temperature
P2	gauge	oil pressure (optional)
P3	gauge	tachometer with running-time meter
H22	warning horn	
E10	lighting	engine coolant temperature gauge
E11	lighting	oil pressure gauge (optional)
E12	lighting	tachometer gauge
X8	1-pin plug	connector illumination switch
X24	8-pin plug	connector STEYR MOTORS – display
Z1	splice	battery +
Z2	splice	battery –
Z3	splice	ignition (+)
Z4	splice	key switch constant revolution
24 V	interm. cable	charge indicator





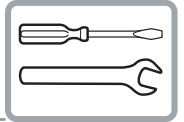

**Wiring diagram external SE E-Box, 6 cyl.**

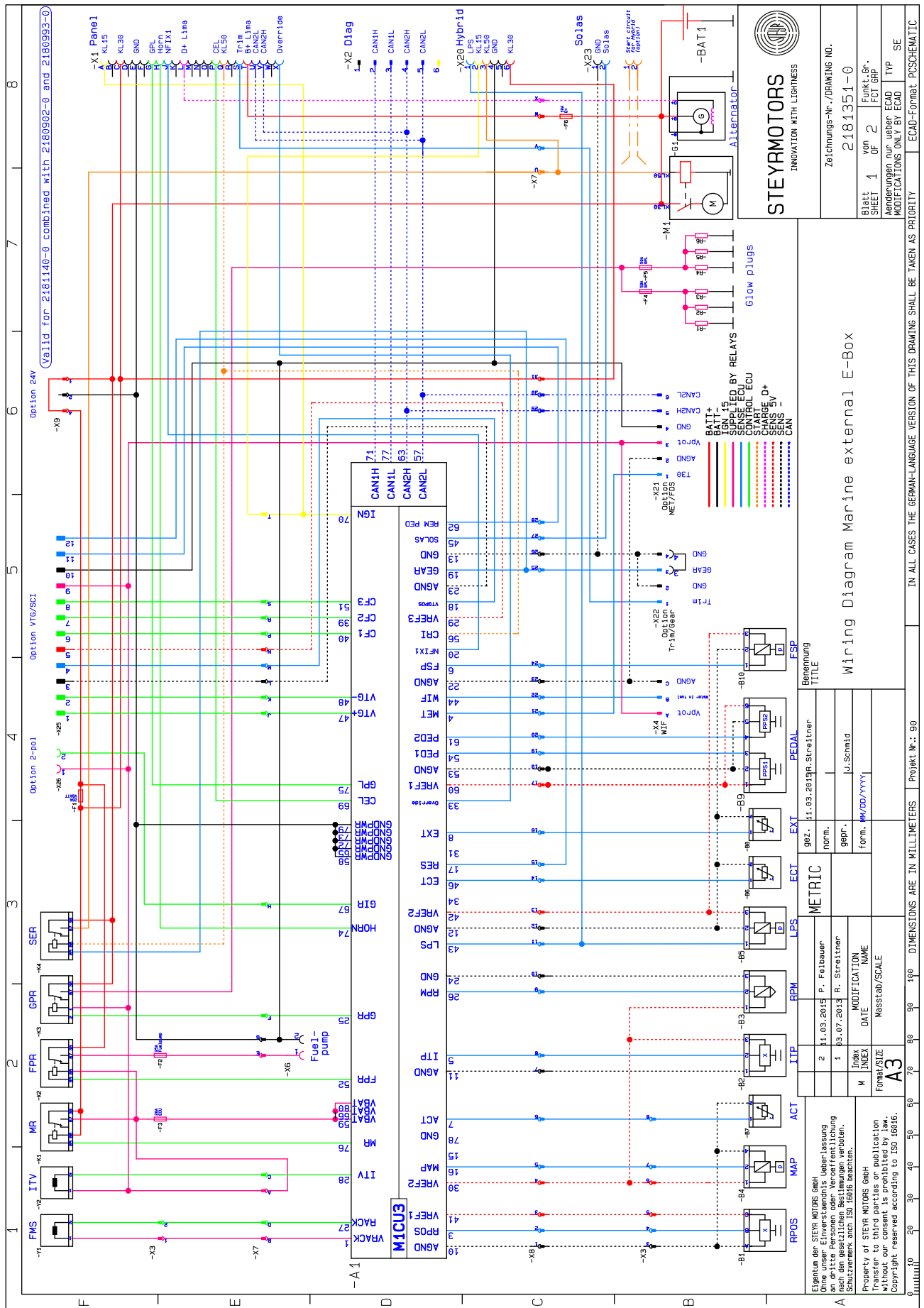

**STEYRMOTORS**  
INNOVATION WITH LIGHTNESS

Zeichnungs-Nr./DRAWING NO.		2181351-0	
Blatt / SHEET	von / of	Funkt. Gr. / FC1 Group	TYP
1	2		SE
Änderungen / Changes MODIFICATIONS ONLY BY ECAD			
ECAD-Format: PVSCHMATIC			

**Wiring Diagram Marine external E-Box**

Benennung / TITLE		90Z - 11.03.2015 P. Streitner	
METRIC		norm.	
Index / INDEX		gepr.	J. Schmid
M. DATE		Form.	MW/DD/YYYY
A3		Form/SCALE	Maßstab/SCALE
Eigentum der STEYR MOTORS GmbH One unser Einverständnis Überlassung an dritte Personen oder Veröffentlichung Scheitern nach ISO 15000 wachen.		Property of STEYR MOTORS GmbH Without our consent is prohibited by law. Copyright reserved according to ISO 15000.	
DIMENSIONS ARE IN MILLIMETERS		Projekt Nr.: 90	

IN ALL CASES THE GERMAN-LANGUAGE VERSION OF THIS DRAWING SHALL BE TAKEN AS PRIORITY

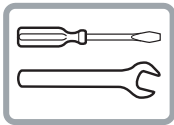

Wiring diagram SE E-Box 12 V, 4 cyl.

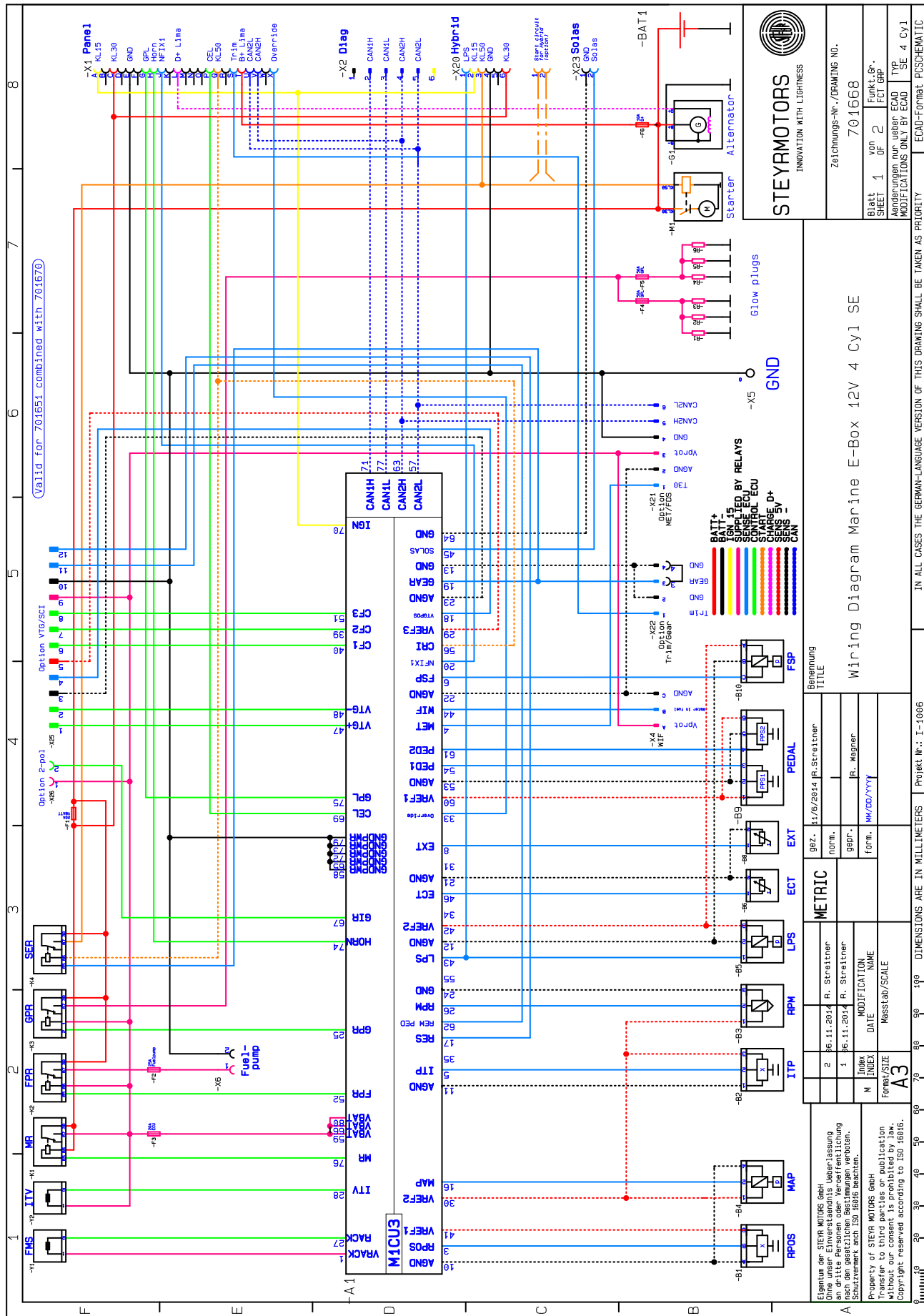



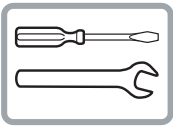

**Wiring diagram Instrument CAN Panel 12/24V**

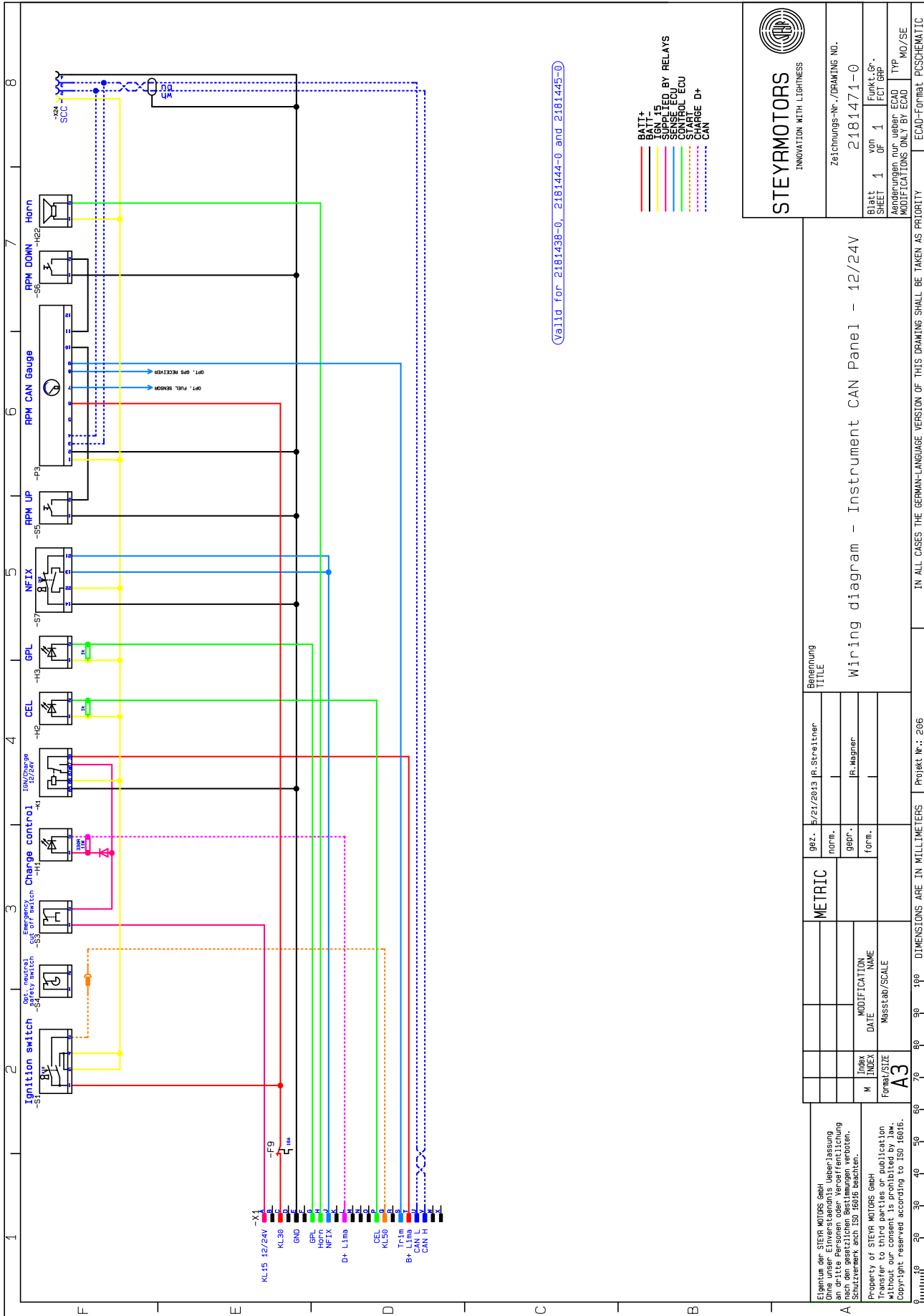

Valid for 2181438-0, 2181444-0 and 2181445-0

- BATT+
- IGN
- SUPPLIED BY RELAYS
- START
- CHARGE D+
- CAN
- CAN-

<p>Steuerung TITEL</p> <p>Wiring diagram - Instrument CAN Panel - 12/24V</p>		<p>gez. 5/21/2013 J. Streitner</p>		<p>Blatt SHEET 1 von 1</p>		<p>Zeichnungs-Nr./DRAWING NO. 2181471-0</p>	
<p>INDEX M</p>		<p>gepr. J. Wagner</p>		<p>Funkt.-Gr. ECT GPP</p>		<p>Typ MO/SE</p>	
<p>MODIFICATION NAME Date</p>		<p>Format/SCALE A3</p>		<p>Änderungen nur über ECAD MODIFICATIONS ONLY BY ECAD</p>		<p>ECAD-Format: PCSHEMATIC</p>	
<p>Dimensionen in Millimetern DIMENSIONS ARE IN MILLIMETERS</p>		<p>Proj. Nr.: 206</p>		<p>IN ALL CASES THE GERMAN-LANGUAGE VERSION OF THIS DRAWING SHALL BE TAKEN AS PRIORITY</p>			



Eigentum der STEYR MOTORS GmbH  
 Ohne unser Einverständnis Weiterlassung  
 an dritte Personen oder Veröffentlichung  
 nach den gesetzlichen Bestimmungen verboten.  
 Schutzvermerk nach § 17 Abs 1 PatG  
 Property of STEYR MOTORS GmbH  
 Transfer to third parties or publication  
 without our consent is prohibited by law  
 Copyright reserved according to § 17 Abs 1 PatG

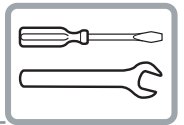

Wiring diagram Instrument CAN Panel Solas 12/24V

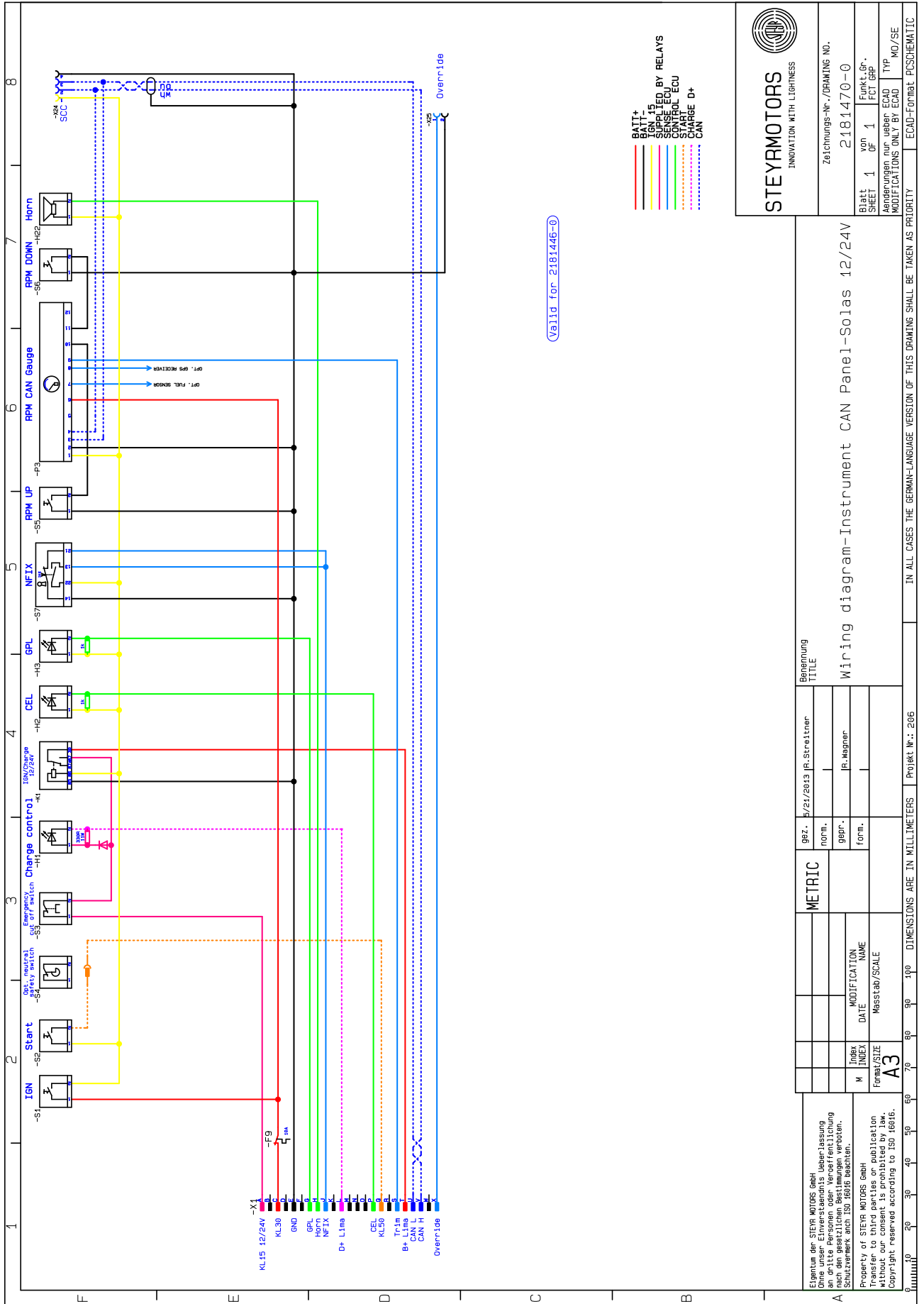

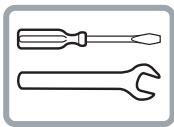

## Operation and Auxiliary Materials

Ordernumber	Short Text	SMB Item	Alternative item
50143	Diesel fuel acc. to EN 590	SADK (CFPP max. -30°C) B0	
50475	Preservation oil	TITAN EM 2020 DEUTZ	
702280	Lubricant	Staloc Blue Moly 500 g	
703074	Silicon grease	Tube 100 g	
705442	Injector grease	Tube 20 g	
706992	PTFE-Special grease	Can 500 g	
9000017-0	Screw lock compound, high strength	Staloc 2S62 (red)	Loctite 262 (red)
9000019-0	Seat sealing compound, high temperature	Staloc 6S20 (green)	Loctite 620 (green)
9000059-0	Screw lock compound, medium	Staloc 2S43 (blue)	Loctite 243 (blue)
9000297-0	Surface sealing compound, medium strength, flexible	Staloc 5S18 (red)	Loctite 518 (red) Loctite 5182 (red)
9000510-0	Surface sealing compound, black	Staloc Silicone sealant	Loctite 5900 (black)
9000540-0	Two component adhesive	Staloc Power 703	
Z010084-0	Hot bearing grease	Staburags NBU4	
Z011785-0	Coolant, ready mixed	CARIX premium concentrate-36 °C	
Z012222	Copper grease	Staloc copper paste	
Z050316-4	Engine oil	ACEA-, API-Servicecodes 10W-40	

For the latest information on alternatives for operation and auxiliary materials please refer to our website [www.steyr-motors.com](http://www.steyr-motors.com).

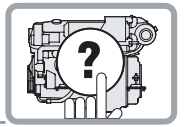

## DEALER'S RESPONSIBILITIES

Check engine oil level.....	112
Refill engine oil .....	112
Oil level for Power Steering .....	112
Oil level for Transmission .....	112
Check coolant (closed cooling circuit) .....	113
Drain the raw water circuit of the engine .....	114
Check raw water connection .....	114
Drain the cooling water circuit of the engine.....	115
Cooling System Anodes .....	116
Anti-Corrosion Anodes.....	117
Propeller Selection .....	120
Preparations for Off-Season Storage .....	121
Start-up after Storage .....	121

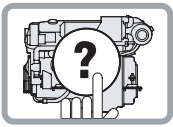

## Check Engine Oil Level

**CAUTION:** Check with cooled down engine only, or after a shut down period of app. 3 to 5 min.



- 19** Then remove oil dipstick (**19/A**), clean it and insert again into oil dipstick tube (**19/A**), then remove again and check oil level on marker.

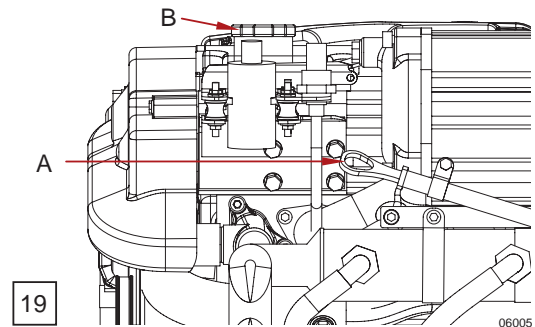

## Refill Engine Oil

Remove engine oil filler cap (**19/B**) and add **Steyr Motors High Performance Diesel Engine Oil** up to specified **maximum marker** on oil dipstick.

**CAUTION:** Engine oil must not exceed maximum marker. An overfilling results in high operating temperatures, foaming (air in oil), loss in efficiency and reduced engine life.



Put on the engine oil filler cap.

**NOTE:** Remove possible oil contaminations. To use engine oil of other quality than specified, warranty expires.

## Oil Level for Power Steering

- 21** Whenever you check engine oil level, also check oil level of power steering. If required, add automatic transmission oil (available with your Steyr Motors Marine dealer). Other approved oils, such as GM Servo or Dexron II, may also be used. Do not overfill pump reservoir.

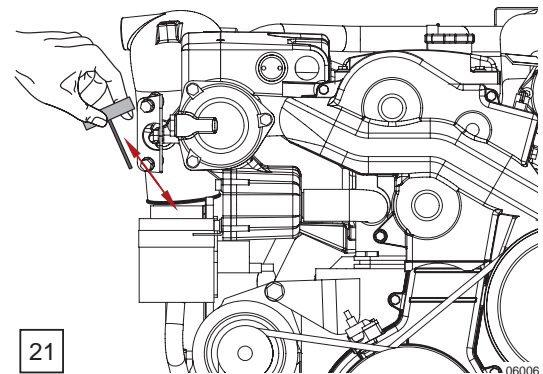

## Oil Level for Transmission

- 22** Whenever you check engine oil level, also check oil level of transmission. If required, add automatic transmission oil (available with your Steyr Motors Marine dealer). Other approved oils, such as GM Servo or Dexron II, may also be used. Do not overfill transmission.

**NOTE:** Consider specifications of respective transmission manufacturer

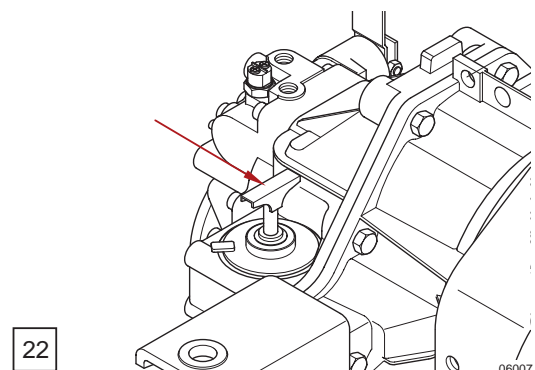

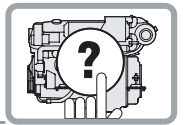



### Check Coolant (Closed Cooling Circuit)

**CAUTION:**  With hot engine, the closed cooling circuit is under pressure. Do not try to open the radiator cap or the drain plugs when engine is hot. This may cause severe injuries by hot coolant. As soon as the engine has cooled down, the cap may be opened.

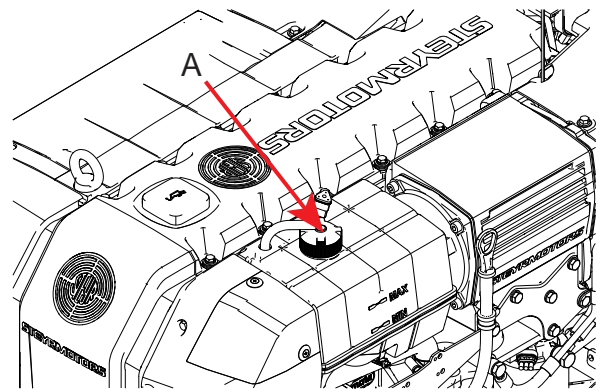
**23** Remove radiator cap **(23/A)**. Coolant level should reach the "MAX" marking **(23/B)** in the expansion tank. Refilling of coolant only at the expansion tank.



**CAUTION:**  Only add Steyr Motors engine coolant. Do not refill at the pressure cap.

**NOTE:** When not using the original Steyr Motors coolant, severe damage to the cooling system of your engine may occur.

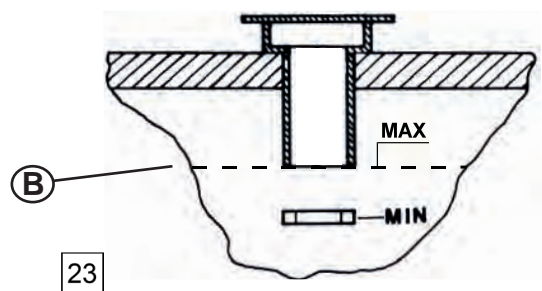

**Drain points of coolant circuit:**

- 1) Engine Block
- 2) Oil Cooler
- 3) Heat Exchanger Housing

### Check Coolant SE-Series

Do not open Pressure Cap if the engine is hot.  
Fill in the coolant until you see it in the upper bulls eye

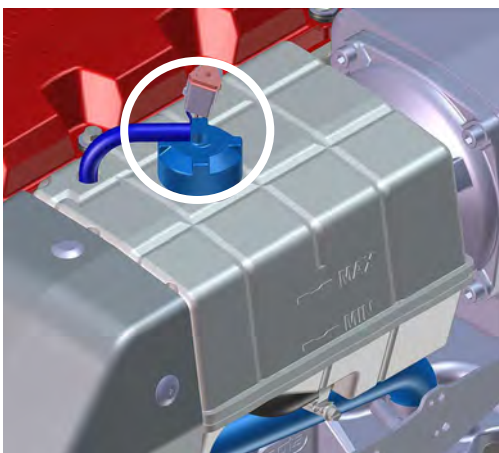

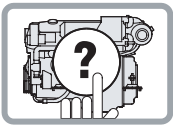

## Drain the Raw Water Circuit of the Engine

**CAUTION:**  Not draining the raw water circuit in time before the winter season and/or daily when running the engine during the winter season, may lead to freeze damage on the engine.

**24** Remove drain plug **(24/A)**. Engine empties itself via exhaust system.

**NOTE:** Drain plug (24/A) is not available for all types, in that case remove the hose.

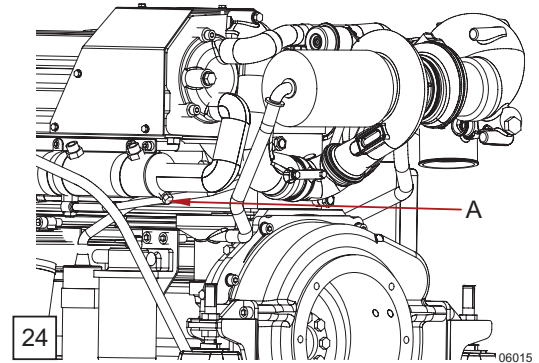

4 cylinder

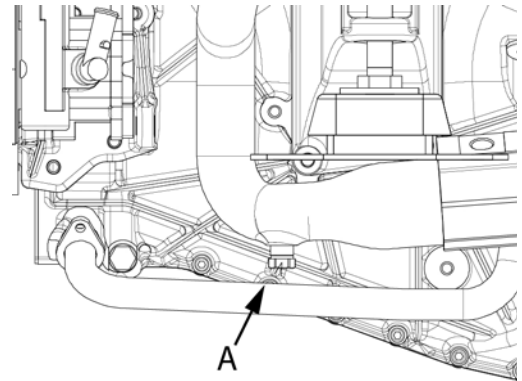

6 cylinder

**25** Loosen 2 hose clamps **(25/A)** and remove raw water hoses, quickly start the engine so that raw water pump empties itself.

**NOTE:** As to procedure for draining the remaining equipment on your boat, see your Steyr Motors Marine dealer.

## Check raw water connection

Filling is done automatically via raw water pump after having started the engine.

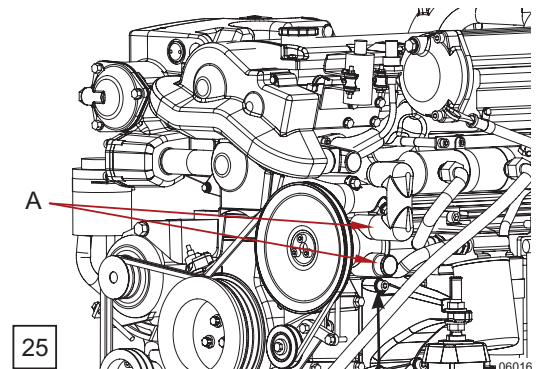

Inlet raw water

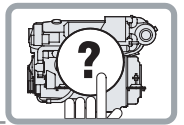

## Drain the cooling water circuit of the engine

**CAUTION:**



Not draining the cooling water circuit in time before the winter season and/or daily when running the engine during the winter season, may lead to freeze damage on the engine.

Remove drain plug **(A)**.

Quickly start the engine so that cooling water pump empties itself.  
To fill or refill see chapter check coolant.

**NOTE:** As to procedure for draining the remaining equipment on your boat, see your Steyr Motors Marine dealer.

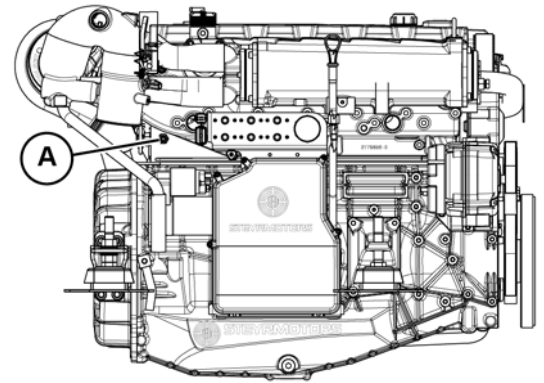

6 cylinder

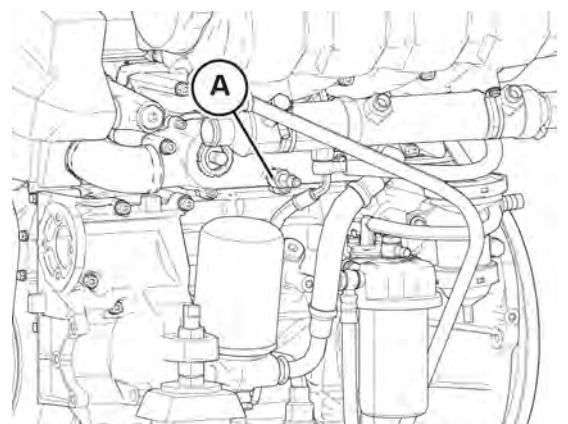
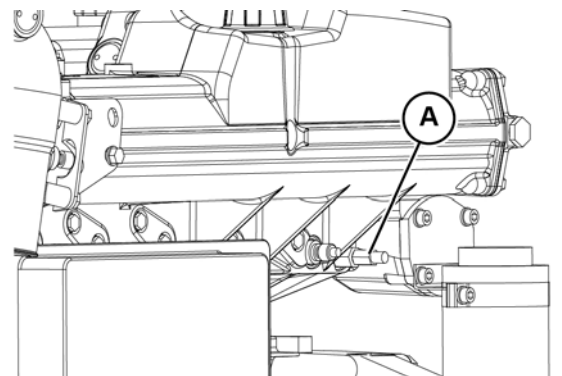

4 cylinder (series SE and MO)

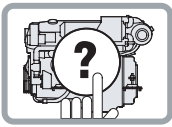

## Cooling System Anodes

### 26/27/27A/27B

For all 4 cylinder (Series MO and SE)

There are 4 sacrificial zinc anodes in the raw water cooling system normally, although if an exhaust high riser is used there is one extra fit in it. Which are installed as per fig. 26, 27 and 27a.

Remove and inspect anodes for galvanic erosion according to the maintenance schedule.

Replace anode when material loss is 50 - 75 %.

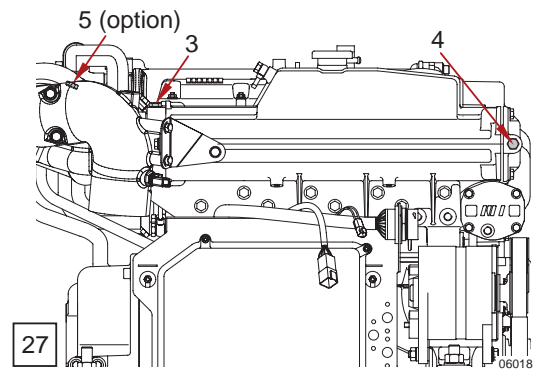
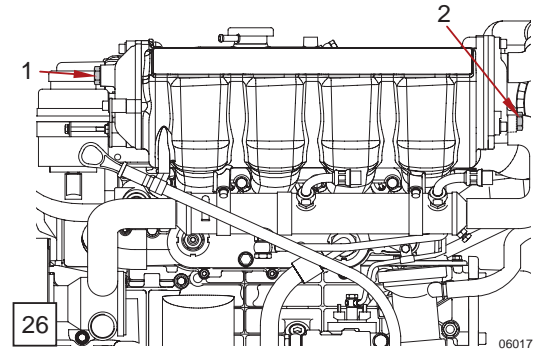

serie MO

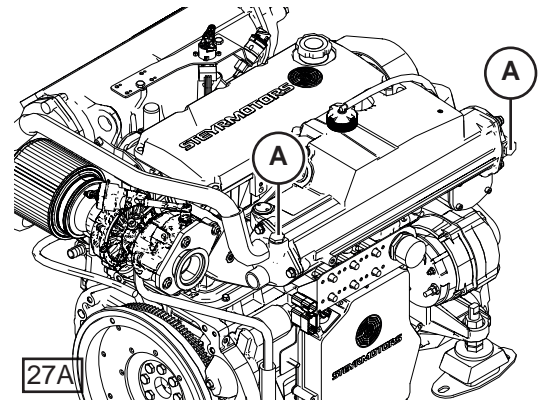

serie SE

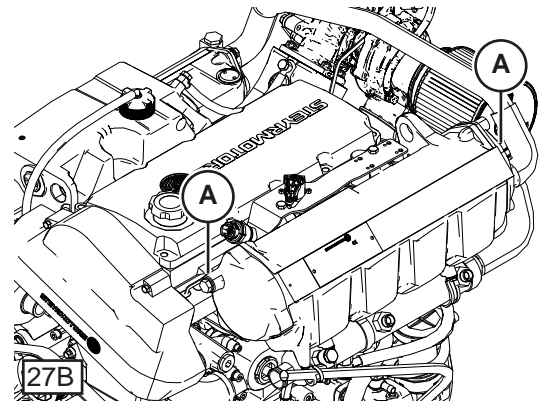

serie SE

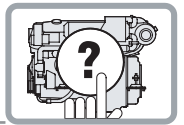

**28/29/30**  
For 6 Cylinder (Series SE)

There are 2 sacrificial zinc anodes in the raw water cooling system normally, If an exhaust high riser is used, there is one extra installed see fig. 28, 29 and 30.

Remove and inspect anodes for galvanic erosion according to the maintenance schedule.

Replace anode when material loss is 50 - 75 %.

**Anti-Corrosion Anodes**

If additional electronic equipment is installed, each should have an individual anode or grounding device and all grounding devices must be interconnected. Follow recommendations of manufacturers of equipment.

**NOTE:** Inspect anodes every 30 days, or more frequently if used in extremely salty water. Anode is to be replaced according to the maintenance schedule.

Boats that connect to an AC power source (shore power) require protection against increased potential of galvanic and “spray current” corrosion. For protection, a galvanic isolator can be installed in series with the grounding (green) wire in the shore power cable between the boat and the shore power outlet on the dock. The isolator blocks direct current (DC) flow, but permits the passage of alternating current (AC) thus providing a path for ground fault currents.

**NOTE:** If a boat is connected to an AC power source (shore power), and it is not equipped with a galvanic isolator, the zinc anti-corrosion anodes may be unable to handle the added corrosion potential.

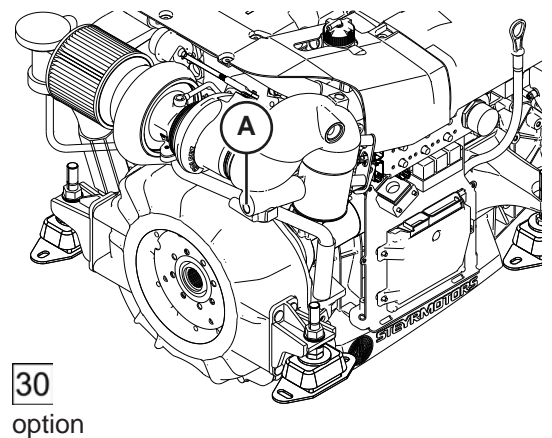
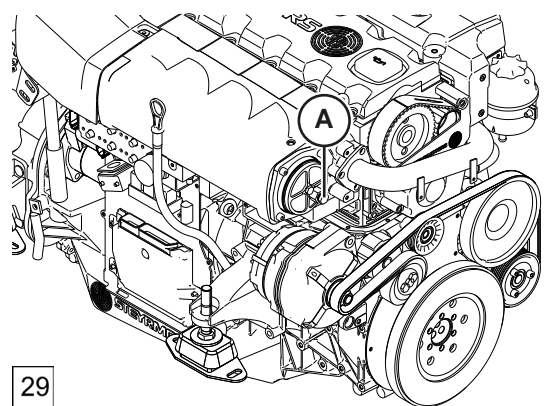
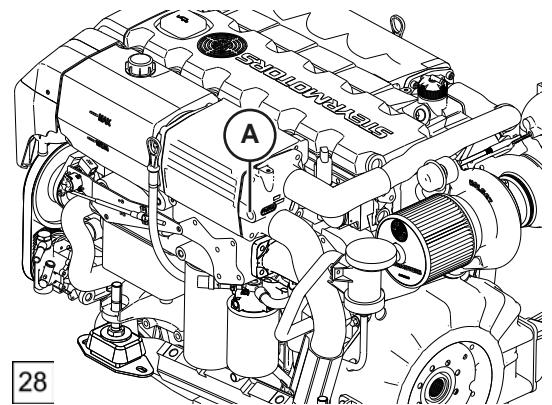

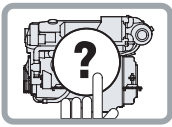

## Air Filter

All Steyr Motors Marine Engine models are equipped with an air filter at the turbocharger inlet; as to specifications, see **Specifications and Maintenance**.

- 31** Loosen clamp to exchange air filter. Remove air filter. Place clamp on filter neck and mount air filter onto flange. Tighten clamp (3 Nm).

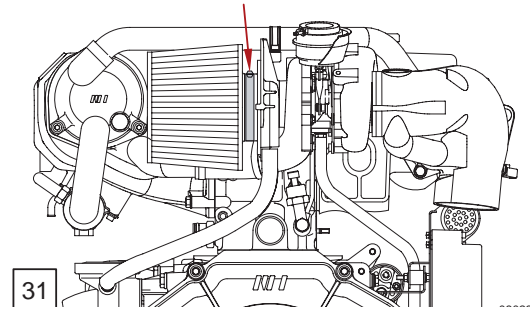

Maintenance Poly-V-belt resp. Serpentine Belt

### FOR 4 CYL. MARINE ENGINES

- 32** Occasionally check components for excessive wear and/or clearance on tension bearing.

NOTE\*): It is recommended to spray frequently some corrosion inhibiting spray into the spring housing of the belt tensioner.

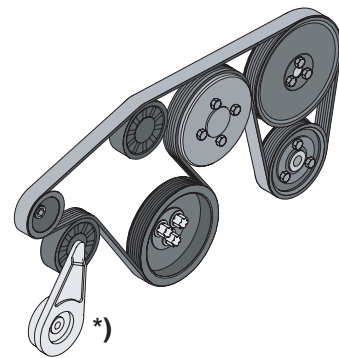

### FOR 6 CYL. MARINE ENGINES

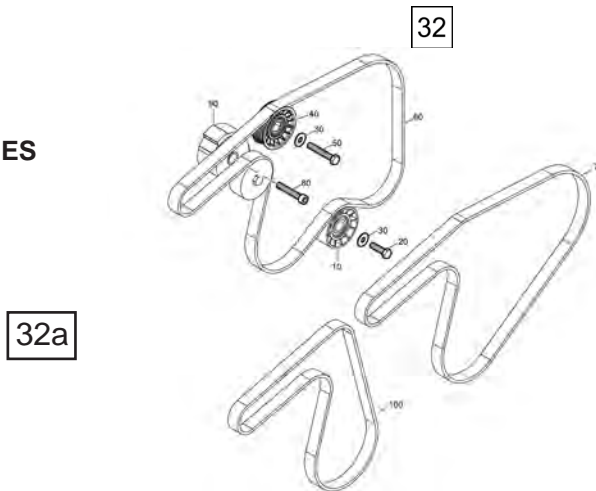

Occasionally check components for excessive wear and/or clearance on tension bearing.

NOTE: **32a** It is recommended to spray frequently some corrosion inhibiting spray into the spring housing of the belt tensioner

## Engine alignment

Engine alignment requires special tools. The output coupler must be disengaged from the take-off shaft. This should be rechecked during off-season storage preparations. Because of the special tools required, engine alignment is to be performed by a Steyr Motors Marine dealer.

NOTE: Failure to check the engine alignment could result in premature failure of engine coupler or universal joints.

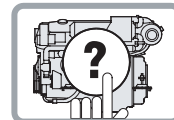

FOR 6 CYL. MARINE ENGINES WITH AC-COMPRESSOR (optional)

### 33/34

**To tension the poly v-belt:** Loosen hexagon screw **(33/F)**. Turn the clamping bolt **(34/G)** clockwise in order to increase the belt tension to  $200 \pm 25$  Nm. Tighten hexagon screw **(35/F)** with a Torque of  $23 \pm 2$  Nm to secure idle pulley bracket. Check belt tension.

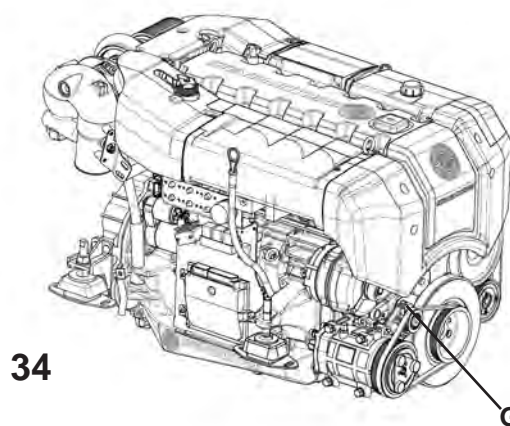
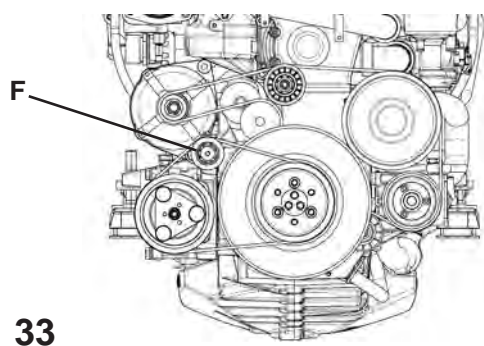

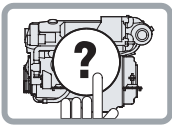

## Propeller Selection

**35** Your Steyr Motors Marine dealer has chosen a propeller designed to deliver top performance and economy under most conditions. To obtain the maximum percentage of available output (Ⓐ), the engine RPM at **Full Throttle** should be in the specified **Propped Speed Range** (Ⓑ). As to specifications, see **Technical Data and Maintenance**.

If the engine's full throttle RPM with normal load is below the specified range, use a propeller with less pitch to increase the RPM. Should the engine's full throttle RPM exceed the specified range, the engine RPM and output is limited by the governor. Use a propeller of higher pitch to achieve a RPM reduction in the specified range (Ⓑ).

**NOTE:** Engine damage can result from incorrect propeller selection if

- The engine RPM **does not attain** the specified **“Propped Speed Range”**.  
The engine thus runs in RPM range (Ⓒ).  
Therefore, use a propeller with a lower pitch.
- The engine RPM exceeds the specified **“Propped Speed Range”**.  
Engine speed is therefore above the admissible range (Ⓓ).  
Therefore, use a propeller with a **higher pitch**.

engine model		Propped Speed Range “B”	
		rated rpm	range of tolerance
4 cylinder MO	MO54NA33	3300 rpm	+0 rpm / -200 rpm
	MO84K32	3200 rpm	+0 rpm / -200 rpm
	MO94K33	3300 rpm	+0 rpm / -200 rpm
	MO114K33	3300 rpm	+0 rpm / -200 rpm
	MO144V38	3800 rpm	+0 rpm / -300 rpm
	MO144M38	3800 rpm	+0 rpm / -300 rpm
	MO164M40	4000 rpm	+0 rpm / -300 rpm
	MO174V40	4000 rpm	+0 rpm / -300 rpm
6 cylinder	SE126E25	2500 rpm	+50 rpm / -200 rpm
	SE156E26	2600 rpm	+50 rpm / -200 rpm
	SE156E32	3200 rpm	+50 rpm / -200 rpm
	SE156E34	3350 rpm	+150 rpm / -150 rpm
	SE196E35	3500 rpm	+50 rpm / -200 rpm
	SE236E40	4000 rpm	+100 rpm / -100 rpm
	SE236S36	3600 rpm	+50 rpm / -200 rpm
	SE266E40	4000 rpm	+50 rpm / -150 rpm
	SE266S36	3600 rpm	+50 rpm / -300 rpm
	SE286E40	4000 rpm	+150 rpm / -100 rpm
	SE306J38	3800 rpm	+50 rpm / -300 rpm
	4 cylinder SE	SE144E38	3800 rpm
SE164E40		4000 rpm	+100 rpm / -100 rpm

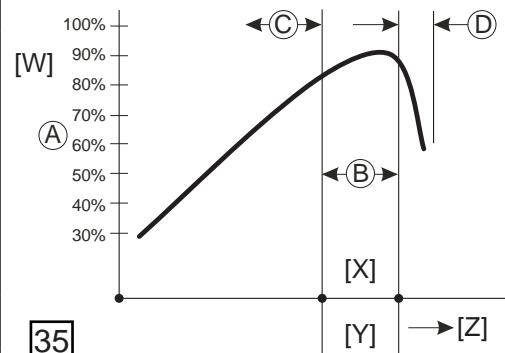

[W] Output power  
[X] Full load  
[Y] Speed range  
[Z] RPM

Jet Speed Range  
(only for Waterjet applications)

3300-3800 rpm

3550-4000 rpm

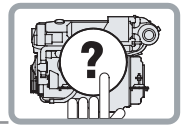

## Preparations for Off-Season Storage

An adequate preservation of the engine will contribute to an efficient and trouble free operation in the long term. Consult your **Steyr Motors Marine Dealer** to get professional assistance in performing a proper off season storage.

**NOTE:** If engine is stored above 1 year, advise your **Steyr Motors Marine Dealer** to the Extended Preservation Procedure (Service Manual Z001138-0, chapter GENERAL D4).

1. Change motor oil and oil filter.
2. Change fuel filter.
3. Check air filter.
4. Check coolant (closed circuit).
5. Drain engine's raw water system.

**NOTE:** If the raw water is not completely removed from the engine, expensive freeze damage may be the result.

6. Drain raw water system from boat and driving system (consider manufacturer's instructions as to storage).
7. Change gear oil or lubricant.
8. Disconnect battery and store it.
9. Spray engine outside with corrosion prevention oil.
10. Ventilate engine compartment and bilge.

## Start-up after Storage

An correct start-up of the engine will contribute to an efficient and trouble-free operation in the long term. Your **Steyr Motors Marine Dealer** will gladly be available as consultant or for an expert performance.

1. Check condition of hoses and hose clamps.
2. Clean battery terminals.

**CAUTION:** Connect RED cable to positive terminal and then BLACK cable to negative terminal. Wrong connection of battery terminals may damage the electronic system.



3. Grease outer sides of terminals.
4. Open fuel stop valve and check all fuel lines for leakage.
5. Thoroughly check the boat and engine for slack or missing screws or nuts.
6. Pump the bilge dry and clean the engine compartment.
7. Complete the raw water system.
8. Open the raw water inlet.

**CAUTION:** Insufficient raw water supply may damage the engine and the raw water pump.



9. Test run. Start engine. Check voltmeter, oil pressure- and water temperature gauge. (Make sure that all systems function properly.)
10. Check all parts for oil-, fuel- or water leakage.

**NOTE:** For additional Information regarding engine preparation for long term preservation please consult your Steyr Motors Marine Service Partner.







**WARRANTY**

**STEYR MOTORS LIMITED ENGINE WARRANTY .....126**

    Products Warranted ..... 126

    What You Must Do to Activate the Warranty ..... 126

    Base Engine Warranty ..... 127

    Extended Major Components Warranty ..... 129

    Summary of Warranty Coverage ..... 129

    Additional Coverage for Parts Replaced or Repaired Under Warranty..... 130

    Warranty Coverage for genuine Spare Parts ..... 130

    Conditions of Warranty Coverage..... 130

    Limitations and Exclusions..... 131

    Procedure for Making a Warranty Claim ..... 133

    Venue and Applicable Law..... 134

    Miscellaneous ..... 134

    If You Do Not Receive Satisfactory Warranty Service ..... 134

**U.S. EPA EMISSION CONTROL WARRANTY .....135**

    Limitations and Exclusions..... 136

    Warranty Claim Procedure..... 138

    Miscellaneous ..... 138



**NOTE:** Steyr Motors Betriebs GmbH reserves the right to publish the latest Version of the Limited Engine Warranty Conditions under following link to Steyr Motors Homepage: <http://www.steyr-motors.com>

Edition 10.12.2019

## STEYR MOTORS LIMITED ENGINE WARRANTY

Steyr Motors Betriebs GmbH ("Steyr Motors") warrants to the original retail purchaser of a product covered under this Warranty ("the Product"), and to any other person to whom the Product is transferred during the duration of this Warranty, that in the event of a failure of the Product occurring during the applicable warranty period resulting from a defect in materials or factory workmanship, Steyr Motors will, at its option, repair or replace the defective Product according to the terms and conditions set forth herein.

### Products Warranted

This Limited Warranty applies to all new marine engines manufactured by Steyr Motors, and sold by Steyr Motors or by a Steyr Motors approved distributor or dealer until such time as this Warranty may be subsequently updated or revised. This Warranty also applies to the following engine accessories when approved and supplied by Steyr Motors and when installed by Steyr Motors or by a Steyr Motors approved distributor or dealer:

- acc. To enlisted distributor as stated in Steyr Motors Service Network (refer to website at <http://www.steyr-motors.com>)

This Warranty does *not* apply to any component manufactured by a third party and supplied by Steyr Motors as part of a package. Such non-covered components include, but are not limited to, any MerCruiser Bravo Series stern drive, ZF Marine transmissions, sail drives, water jet and commander systems, etc., that may be sold together with a Steyr engine. Buyers of a package that includes a MerCruiser Bravo Series stern drive should consult the product literature accompanying the stern drive for details on the warranty provided by its manufacturer, Mercury Marine. The provided warranty registration card with the Mercury Marine/MerCruiser product needs to be returned to Steyr Motors for registration in their system.

### What You Must Do to Activate the Warranty

#### Owner Registration

**IMPORTANT: In order to obtain the full benefit of this Warranty, your new Steyr engines must be timely registered at the factory, latest within 3 years from the date of sales document.**

It is your responsibility to insure that the Steyr Motors distributor, dealer or OEM from whom you purchased the engine(s), registers your engine(s) at the Steyr Motors factory and re-confirms this to you in the Operation, Maintenance and Warranty Manual/chapter Warranty/Warranty Registration Approval.

The Warranty Registration Approval must include product number and serial number(s), vessel -builder -model and - serial number, impeller/propeller- size, Date of Commissioning and warranty expiration-date by Steyr Motors. It must also contain the Issuer's -name, -Company,-address and -signature as well as the Owner's -name,-address and -signature.

In case of an engine doesn't get put into operation within the first year from production, the Steyr Motors long-term preservation and conservation procedure must be followed and documented as described in this procedure to prove proper storage handling and re-commissioning of the product.

**A copy of the Warranty Registration Approval MUST be given to you immediately after the document has been completed by the selling Steyr Motors distributor, dealer or OEM.** In the event of warranty service work, you can prove via the Warranty Registration Approval to any Steyr Motors distributor/dealer that your product has been successfully registered at the Steyr Motors factory.

**NOTE:** Steyr Motors Betriebs GmbH reserves the right to publish the latest Version of the Limited Engine Warranty Conditions under following link to Steyr Motors Homepage: <http://www.steyr-motors.com>

Edition 10.12.2019

Failure to register the Product with the factory within 60 days of the date on which you take delivery of the Product will cause the warranty period to begin running from the date on which the Product is shipped from Steyr Motors in Austria, rather than on the date of delivery to you. It is to your benefit to have all Products timely registered at the factory so that you receive the maximum available coverage under the Warranty and so that Steyr Motors has a means of identifying and contacting you in the event of product updates or service notifications.

### **Commissioning Report**

**It is the sellers (Steyr Motors distributor, dealer or OEM) responsibility to send a completed "Commissioning Report" to Steyr Motors factory for a successful warranty registration of the engines.**

Without any official acknowledgment from Steyr Motors factory, the seller (Steyr Motors distributor, dealer or OEM) must not sign the Warranty Registration Approval in the Operation, Maintenance and Warranty Manual.

In case the Warranty Registration Approval has been signed irregardless of the official confirmation from Steyr Motors factory, Steyr Motors cannot be held responsible for any warranty. Under such circumstances the warranty coverage becomes full responsibility of the signing-party!

### **Base Engine Warranty**

The Base Engine Warranty covers any failure of the Product under normal use and service that occurs during the applicable period of coverage and that results from a defect in Steyr Motors material or factory workmanship (a "Warrantable Failure").

#### **Steyr Motors' Responsibilities under the Base Engine Warranty**

During the applicable period of coverage under the Base Engine Warranty, and subject to all conditions, limitations and exclusions herein, Steyr Motors will, at its option, either repair or replace the defective Product. In the event that Steyr Motors elects to repair the Product, Steyr Motors will do the following:

- Steyr Motors will pay for all parts and labor reasonably required to repair the defect responsible for the Warrantable Failure.
- Steyr Motors will pay for all lubricating oil, antifreeze, filter elements, and other similar maintenance items replaced during a warranty repair when such items are not reusable due to a Warrantable Failure.
- Steyr Motors will pay for the usual and customary labor costs for engine removal and reinstallation when necessary to repair a Warrantable Failure.

Labor costs will be paid by Steyr Motors only for work pre-authorized by Steyr Motors and performed by an approved service facility during normal business hours. Labor costs will be paid in accordance with Steyr Motors' published standard repair time guidelines. Parts used in warranty repairs may be new Steyr Motors parts, Steyr Motors-approved rebuilt parts, or repaired parts.



**NOTE:** Steyr Motors Betriebs GmbH reserves the right to publish the latest Version of the Limited Engine Warranty Conditions under following link to Steyr Motors Homepage: <http://www.steyr-motors.com>

Edition 10.12.2019

### **Duration of Coverage**

The duration of coverage under the Base Engine Warranty depends upon whether your engine application and use are rated for “Pleasure Duty” or for “Commercial Duty.”

- For engines rated “Pleasure Duty,” the Base Engine Warranty extends for a period of 24 months or until the engines have been operated for 1,000 hours, whichever occurs first.
- For engines rated “Commercial or Government Duty,” the Base Engine Warranty extends for a period of 12 months or until the engines have been operated for 1,000 hours, whichever occurs first.

The period of coverage commences on the date on which the Product is delivered to the first retail purchaser, or the date on which the unit is first leased, rented or loaned, or when the Product has been operated for 30 hours, whichever occurs first.

**NOTE:** Steyr Motors Betriebs GmbH reserves the right to publish the latest Version of the Limited Engine Warranty Conditions under following link to Steyr Motors Homepage: <http://www.steyr-motors.com>

Edition 10.12.2019

**Extended Major Components Warranty**

The Extended Major Components Warranty covers any failure under normal use and service of any of the below-listed parts or castings<sup>1</sup> that occurs during the extended warranty period and that is caused by a defect in material of original manufacturer:

- Engine Monoblock Casting
- Engine Camshaft
- Engine Crankshaft
- Engine Connecting Rods
- Crankshaft Sprocket
- Camshaft Sprocket
- Engine Housing
- Flywheel Housing

**Steyr Motors’ Responsibilities under the Extended Major Components Warranty**

During the applicable period of coverage under the Extended Major Components Warranty, and subject to the conditions, limitations and exclusions herein, Steyr Motors will, at its option, either repair or replace the defective component. Steyr Motors’ responsibilities in the event of a repair shall be the same as provided with respect to the Base Engine Warranty, except that the cost of labor for removal and reinstallation is not covered under the Extended Major Components Warranty.

**Duration of Coverage for specific major engine components**

The Extended Major Components Warranty extends for a period of 60 months or until the engine has been operated for 1,800 hours, whichever occurs first. As with the Base Engine Warranty, the period of coverage commences on the date on which the Product is delivered to the first retail purchaser or on the date on which the unit is first leased, rented or loaned, or when the Product has been operated for 30 hours, whichever occurs first.

**Summary of Warranty Coverage**

Type of Coverage	Duration (Months)*	Duration (Hours or KM)*	Repair Costs Paid by Steyr Motors		
			Parts	Labor	Labor for Removal & Reinstallation
Base Engine Warranty – PLEASURE	24	1,000	Yes	Yes	Yes
Base Engine Warranty – COMMERCIAL	12	1,000	Yes	Yes	Yes
Extended Major Components Warranty	60	1,800	Yes	Yes	No

\* whichever occurs first

<sup>1</sup>Bushing and Bearing failures are not covered.



**NOTE:** Steyr Motors Betriebs GmbH reserves the right to publish the latest Version of the Limited Engine Warranty Conditions under following link to Steyr Motors Homepage: <http://www.steyr-motors.com>

Edition 10.12.2019

## **Additional Coverage for Parts Replaced or Repaired Under Warranty**

Any Steyr Motors product or part replaced or repaired under the Base Engine Warranty will be covered under the Base Engine Warranty for the remaining period of warranty.

## **Warranty Coverage for genuine Spare Parts**

Steyr Motors warrants genuine spare parts for extent of 6 month beginning from the date of repair.

## **Conditions of Warranty Coverage**

This Warranty is expressly conditioned upon proper application, installation, commissioning, operation, and maintenance of the Product in accordance with the specifications and guidelines set forth by Steyr Motors in its Operations, Maintenance and Warranty Manual and in its Installation- and Service- Manuals. Proper use and operation of the Product entails, among other things, use of the Product in strict compliance with the following power ratings:

**Pleasure Duty (PD).** This power rating is intended for use in variable load applications where full power is limited to one (1) hour out of every eight (8) hours of operation. Reduced power operations must be at or below cruise speed (rpm). Cruise speed (rpm) is 200 rpm below the engine rated speed (rpm). Also, the defined propped speed range must be met and is specified in table propped speed range (Operator Manual, chapter Propeller selection) for each engine model. This rating (ISO3046 Fuel Stop Power Rating) is for application operating less than 300 hours per year and is intended exclusively for pleasure/non-revenue generating applications.

Engines rated "Pleasure Duty" may not be used for any commercial application without voiding the product warranty. A "commercial or governmental application" includes any work or employment-related use of the Product, or any use of the Product that creates income, even if the Product is only occasionally used for such purpose. A "commercial application" also includes charter, naval, police, and other similar applications.

**Commercial or Governmental Duty** according to Marine Duty Rating. If an engine is intent to be used for commercial operation the application must comply with below described duty rating conditions. The duty ratings are defined in three different engine operation pattern and annual use of the unit. The operation pattern defines a ratio between full power-speed-range and cruising-speed-range, wherein cruising speed must be maintained on a specified reduced rpm below the engine rated speed. The specified reduced speeds are mentioned in the Marine Duty Ratings below.

**High Output (HO).** This power rating is intended for intermittent use in variable load applications where full power is limited to one (1) hours out of every eight (8) hours of operation. Reduced power operations must be at or below cruise speed (rpm). Cruise speed (rpm) is 300 rpm below the engine rated speed (rpm). Also, the defined propped speed range must be met and is specified in table propped speed range (Operator Manual, chapter Propeller selection) for each engine model. This rating (ISO3046 Fuel Stop Power Rating) is for application operating less than 300 hours per year.

**Intermittent Rating (INT).** This power rating is intended for intermittent use in variable load applications where full power is limited to two (2) hours out of every eight (8) hours of operation. Reduced power operations must be at or below cruise speed (rpm). Cruise speed (rpm) is 200 rpm below the engine rated speed (rpm). Also, the defined propped speed range must be met and is specified in table propped speed range (Operator Manual, chapter Propeller selection) for each engine model. This rating (ISO3046 Fuel Stop Power Rating) is for application operating less than 1,500 hours per year.

**NOTE:** Steyr Motors Betriebs GmbH reserves the right to publish the latest Version of the Limited Engine Warranty Conditions under following link to Steyr Motors Homepage: <http://www.steyr-motors.com>

Edition 10.12.2019

**Medium Continuous Rating (MCD).** This power rating is intended for intermittent use in variable load applications where full power is limited to three (3) hours out of every twelve (12) hours of operation. Reduced power operations must be at or below cruise speed (rpm). Cruise speed (rpm) is 400 rpm below the engine rated speed (rpm). Also, the defined propped speed range must be met and is specified in table propped speed range (Operator Manual, chapter Propeller selection) for each engine model. This rating (ISO3046 Fuel Stop Power Rating) is for application operating less than 3,000 hours per year.

Steyr Motors' duty of performance under this Warranty is expressly conditioned upon the purchaser's maintenance of the following documentation and records which must be made available to Steyr Motors in the event that warranty service is required:

- You are responsible for keeping complete and accurate records of all service performed on the engines and for maintaining a log of all regularly scheduled maintenance in the Owner Service Log included in your Operations, Maintenance and Warranty Manual.
- You are responsible for assuring that at all times the engine hour meter on your Steyr engines is in good working order and in a condition that accurately reflects the total hours that the engines have been operated.
- You are responsible for keeping copies of the completed Warranty Registration Approval

### Limitations and Exclusions

Steyr Motors is not responsible for any engine failure or other problem attributable in whole or in part to any of the following:

- Any application or installation inconsistent with Steyr Motors' published application and installation guidelines.
- Abuse or neglect, including but not limited to operation without adequate coolants or lubricants, over-fueling, over-speeding, lack of maintenance of cooling, lubricating or intake systems, improper storage, preservation, rust or corrosion, improper starting, warm-up, run-in or shutdown practices, or failures caused by incorrect oil or by water, dirt or other contaminants in the fuel or oil.
- Unauthorized modifications of the engine.
- Use of a service facility not approved by Steyr Motors, or use of parts not supplied or approved by Steyr Motors. For information on approved service partner in your area, please contact Steyr Motors or refer to the list of approved service facilities posted on Steyr Motors' website at [www.steyr-motors.com](http://www.steyr-motors.com).
- Prolonged or incorrect storage. Prolonged storage, for purposes of this Warranty, is storage for a period of over one (1) year from the date of shipment from the Steyr Motors factory.
- Normal wear or wearout of parts.
- Faulty workmanship, whether or not performed by an approved dealer or distributor of Steyr Motors, and whether or not occurring in conjunction with a warranty repair.



**NOTE:** Steyr Motors Betriebs GmbH reserves the right to publish the latest Edition 10.12.2019  
Version of the Limited Engine Warranty Conditions under following link  
to Steyr Motors Homepage: <http://www.steyr-motors.com>

Steyr Motors will not pay for any of the following costs, which shall be the sole responsibility of the Owner:

- The cost of transporting any Steyr Motors engine or product to or from the place of warranty service.
- The cost of haulage, launch, docking, or cranes.
- The cost of lubricating oil, antifreeze, filter elements, and other maintenance items replaced during warranty repairs unless such items are not reusable because of the Warrantable Failure.
- The cost of any part supplied, or labor performed, by a service facility not approved by Steyr Motors.
- The cost of any part supplied, or labor performed, by a service facility without the prior authorization of Steyr Motors.

Steyr Motors does not warrant any product or component not specifically identified in the “Products Warranted” section of this document. Please note in particular the following:

- Steyr Motors does not warrant any product or component not manufactured by Steyr Motors, except for those accessories specifically identified in the “Products Warranted” section of this document that are supplied by Steyr Motors and installed by Steyr Motors or by a Steyr Motors approved distributor or dealer. Examples of items not warranted are stern drives, sail drives, gear boxes, and water jets, commander systems, etc.
- Steyr Motors does not warrant maintenance components supplied by Steyr Motors after 90 days of the date on which warranty coverage commences. Maintenance components include, but are not limited to, sea water pump impellers, zinc plugs, oil filters, fuel filters, air filters, water filters, fuel/water separator filters, belts, automatic belt tensioner, timing belt and idler, gaskets, hoses, fuses, brushes and accommodator, fuel injection nozzle valves, expansion tank pressure caps, and thermostats.
- Steyr Motors products are not entitled to limited warranty coverage, if the Commissioning Report has not been submitted to / received by Steyr Motors within 3 years from the date of manufacturing.

**IN NO EVENT SHALL STEYR MOTORS BE RESPONSIBLE FOR INCIDENTAL OR CONSEQUENTIAL DAMAGES.** Such excluded damages include, but are not limited to, loss of use (including “down time”), loss of income or business revenue, costs of travel, costs of transport, extra costs required to make the Product accessible as a result of particular vessel designs and/or installations (including the removal and/or replacement of partitions or material), personal injury, loss of property, cargo damage, fines, taxes, damages to parts or goods other than products specifically covered by this Warranty, and any other indirect or consequential loss resulting from a Warrantable Failure. **Some states do not allow limitations on how long an implied warranty lasts, so the above limitation may not apply to you.**

**THE WARRANTIES SET FORTH HEREIN ARE THE ONLY WARRANTIES MADE BY STEYR MOTORS WITH RESPECT TO THE PRODUCT. NO DEALER OR DISTRIBUTOR OF STEYR MOTORS IS AUTHORIZED TO MAKE ANY ADDITIONAL WARRANTY, PROMISE, OR REPRESENTATION ON BEHALF OF STEYR MOTORS OR TO MODIFY OR EXTEND THE TERMS OR DURATION OF THIS WARRANTY. ANY WARRANTY IMPLIED BY LAW, INCLUDING ANY IMPLIED WARRANTY OF MERCHANTABILITY OR OF FITNESS FOR A PARTICULAR PURPOSE, SHALL BE LIMITED IN DURATION TO THE TERM OF THIS WARRANTY.**

**NOTE:** Steyr Motors Betriebs GmbH reserves the right to publish the latest Version of the Limited Engine Warranty Conditions under following link to Steyr Motors Homepage: <http://www.steyr-motors.com>

Edition 10.12.2019

### Procedure for Making a Warranty Claim

Warranty service may be obtained from any approved Steyr Motors distributor or dealer. For a list of approved service locations, please refer to Steyr Motors' website at [www.steyr-motors.com](http://www.steyr-motors.com) or contact Steyr Motors' Customer Service Division, the contact information for which is provided on the final page of this document.

In the event of a Warrantable Failure arising during the applicable warranty period, a warranty claim must be submitted promptly IN WRITING. A warranty claim must be made immediately upon discovery of facts that would lead a reasonably prudent owner to believe that the Product is defective in materials or factory workmanship, but in no event more than 30 days after such discovery.

In case of a warranty claim, please contact any approved Steyr Motors distributor or dealer and present your Warranty Registration Approval (at least your engine serial number). You may also be requested to present a copy of your maintenance- and service- records.

A Steyr Motors Warranty Claim Form (a sample copy of which is available from Steyr Motors' website at [www.steyr-motors.com](http://www.steyr-motors.com)) must be completed by the dealer or distributor and returned to Steyr Motors in Austria. It is your responsibility to insure that the Warranty Form is properly completed and to retain a copy for your records as proof of the making of a timely warranty claim.

All warranty claims MUST be approved by Steyr Motors before any warranty work is undertaken. No distributor or dealer of Steyr Motors is authorized to approve, or to guarantee approval of, a warranty claim. Any work performed prior to obtaining authorization from Steyr Motors will be at the risk of the owner and/or service facility undertaking the work. Upon approval of a warranty claim, you are responsible for making the Product available for repair at the place designated by Steyr Motors within a reasonable period of time.

**Important: The foregoing procedures for making a warranty claim are mandatory. Failure to comply with the requirements for submitting a warranty claim shall be presumed to have deprived Steyr Motors of adequate and timely notice of a defect and shall relieve Steyr Motors of any duty of performance under this Warranty.**



**NOTE:** Steyr Motors Betriebs GmbH reserves the right to publish the latest Version of the Limited Engine Warranty Conditions under following link to Steyr Motors Homepage: <http://www.steyr-motors.com>

Edition 10.12.2019

## Venue and Applicable Law

This Limited Warranty and the rights and obligations of Steyr Motors and of the Owner as they relate to any product supplied by Steyr Motors shall be governed by and construed in accordance with Austrian law, and any legal action instituted against Steyr Motors as a result of this Warranty shall be brought in Vienna, Austria. In the event of a legal action commenced against Steyr Motors in the United States, Steyr Motors shall have the option to consent to jurisdiction and to require that the action be submitted to binding arbitration according to the commercial rules of the American Arbitration Association.

## Miscellaneous

This Warranty document consists of the complete and final expression of the intent of the parties with respect to the warranty obligations of Steyr Motors. The terms of this Warranty may not be modified except by a writing signed by an authorized representative of Steyr Motors. Dealers and distributors of Steyr Motors engines (whether or not approved by Steyr Motors) are not agents of Steyr Motors and have no authority to alter the terms of this Warranty or to waive any condition or requirement stated herein.

Should any portion of this Warranty be determined unenforceable in a court of law, the validity and legal effect of the remainder of the document shall not be affected.

Steyr Motors may in certain circumstances, and at its sole discretion, provide for service outside the scope of this Warranty to update, modify, or repair a product. In that event, Steyr Motors shall not be deemed to have assumed any additional obligation to the owner or to have modified or waived any of the provisions of this Warranty.

The owner shall be responsible for the cost of investigating complaints found not to be attributable to a defect in Steyr Motors material or factory workmanship.

Any Steyr Motors product or part replaced under warranty will automatically become the property of Steyr Motors.

**This warranty gives you specific legal rights, and you may also have other rights which vary from state to state.**

## If You Do Not Receive Satisfactory Warranty Service

Steyr Motors strives, through an extensive network of independent distributors and dealers, to provide prompt, courteous, and competent warranty service to owners of Steyr engines. If you fail to receive satisfactory warranty service from a Steyr Motors distributor or dealer, please contact Steyr Motors customer service division directly.

Its contact information is as follows:

Steyr Motors Betriebs GmbH  
Im Stadtgut B1, 4407  
Steyr, Austria

Phone: +43 7252 222-52  
Fax: +43 7252 222-29

Erstellt / Issued: 15.06.2016 Bearbeitet / Edited: 10.12.2019 Kundendienst / Customer Service	Geprüft und freigegeben / Approved: 10.12.2019 / CEO Dieter Angerer (Datum, Name / Date, Name)
---	--

**U.S. EPA EMISSION CONTROL WARRANTY** (valid only on U.S.-flagged vessels)

Steyr Motors warrants to the first retail purchaser and to each subsequent owner of a new Steyr engine that all parts of its emission control system are:

- 1) Designed, built, and equipped so it conforms at the time of sale to the ultimate purchaser with all applicable U.S. Environmental Protection Agency regulations.
- 2) Free from defects in materials and workmanship that cause the engine to fail to conform to the applicable regulations for the warranty period set below.

**This warranty covers the following list of items that are considered a part of the emission control system if originally installed by Steyr Motors on the engine to comply with EPA regulations:**

- Turbocharger System
- Intercooler
- Exhaust manifold
- Fuel Supply Pump
- Unit Injector
- ECU
- Engine Speed / Timing Sensor
- Coolant Temperature Sensor
- Intake Pressure Sensor
- Intake Manifold Temperature Sensor
- Fuel Pressure Sensor
- Closed Breather System
- Hoses, Clamps, Fittings, Tubing (whose failure affects exhaust emissions)
- Gaskets, Seals
- Emission Control Information Labels
- Air Cleaner\*, Fuel Filter Element\*

\*until the first scheduled replacement point.

The emission control parts listed above are subject to this warranty for 5 years or 5,000 hours, (whichever occurs first).

In case of a warrantable condition, Steyr Motors will repair your engine at no cost to you, including diagnosis, parts and labor. Repairs covered by this warranty will be performed by an authorized Steyr Motors partner.

The warranty shall begin as the Steyr Motors engine is handed over to the first retail purchaser.

Steyr Motors recommends using only parts supplied or approved by Steyr Motors for repair, replacement or maintenance, to ensure maximum emission compliance. Parts not supplied or approved by Steyr Motors may be of questionable quality and cause non-compliance with EPA regulations.

This warranty does not cover the replacement of expendable maintenance parts such as exhaust systems, filters, hoses belts, oil, thermostat and coolant in connection with scheduled maintenance, once these parts have been replaced.



## Limitations and Exclusions

Steyr Motors is not responsible for any product failure or other failure attributable in whole or in part to any of the following:

- Any application or installation inconsistent with Steyr Motors' published application and installation guidelines as well as damages caused by transportation.
- Non-compliance with the Operation, Maintenance and Warranty Manual and any other instructions and documentation supplied.
- Abuse or neglect including but not limited to the operation under a lack of adequate coolant or lubricants, over-fueling, over-speeding, lack of maintenance, rust or corrosion, improper starting, warm-up, run-in or shutdown procedures, failures caused by incorrect or contaminated oil, coolant or fuel, competition use, over- or under-loading, cavitation, accidents, breaking of seals, violation of laws and force majeure.
- Damage that is the result of sand, debris, or any other foreign material being drawn into the water pump and its components.
- Unauthorized modifications of the Product.
- Combination of the Product with any mechanical or electrical product or component not sold and approved by Steyr Motors.
- Service or repair procedures not authorized by Steyr Motors. For proper service and repair work and maximum performance of your Steyr Motors Product, please consult an authorized Steyr Motors partner.
- Use of spare parts not supplied or approved by Steyr Motors.
- Normal wear and tear.
- Faulty workmanship, whether or not performed by an authorized Steyr Motors partner and whether or not occurring in conjunction with a warranty repair.

STEYR MOTORS will NOT pay for any of the following costs:

- The costs of any part supplied, or work performed, by a service facility without the prior written approval of Steyr Motors.
- The costs for lubricating oil, coolant, filter elements, and other equivalent maintenance items replaced during a Warranty repair if such items are not reusable due to a Warrantable Failure.
- The costs for Product removal and reinstallation if necessary to repair a Warrantable Failure.
- The cost of haulage, launching, docking, cranes or storage.
- The transportation costs of a Steyr Motors Product to or from the place where work shall be performed.
- Costs to modify fuel systems or gear ratios to meet local altitude requirements.
- Travel to or from the Steyr Product by the authorized Steyr partner or transportation of the Steyr Product to and from the authorized Steyr partner; charges for towing, haulage, launch, storage, fuel or lubricants usage, premium (air) freight charges; rental costs, and excessive time necessary to disassembly boat partitions, hatches or decks to gain access.

Steyr Motors does not warrant any product or component not specifically identified in the “Products Warranted” section of this document. Please note in particular that STEYR MOTORS DOES NOT WARRANT:

- Maintenance components which include, but are not limited to, sea water pump impellers, zinc plugs, oil filters, fuel filters, air filters, water filters, fuel/water separator filters, belts, automatic belt tensioner, timing belt and idler, gaskets, hoses, fuses, brushes, regulators and commutators expansion tank pressure caps, and thermostats.
- Steyr Products sold or transferred as part of an AS IS transaction without warranties.
- Steyr engines on which the hour meter has been disconnected or the hour record has been altered so the actual usage cannot be determined precisely.

IN NO EVENT SHALL STEYR MOTORS BE RESPONSIBLE FOR INCIDENTAL OR CONSEQUENTIAL DAMAGES AS WELL AS DAMAGES RESULTING FROM SLIGHT NEGLIGENCE. Such excepted damages include, but are not limited to, loss of use (including “down time”), loss of income or business revenue, costs of travel, costs of transport, extra costs required to make the Product accessible as a result of particular vessel designs and/or installations (including the removal and/or replacement of partitions or material), personal injury, loss of property, cargo damage, fines, taxes, damages to parts or goods other than products specifically covered by this Warranty and any other indirect or consequential loss resulting from a Warrantable Failure.

STEYR MOTORS DOES NOT MAKE ANY IMPLIED WARRANTY OF MERCHANTABILITY AS TO ANY PRODUCT OR PART, WHETHER OR NOT THAT PRODUCT OR PART IS COVERED BY ANY EXPRESS WARRANTY CONTAINED HEREIN.

STEYR MOTORS DOES NOT MAKE ANY IMPLIED WARRANTY OF FITNESS FOR A PARTICULAR PURPOSE, AND THERE ARE NO WARRANTIES THAT EXTEND BEYOND THE DESCRIPTION ON THE FACE HEREOF.

IN THOSE JURISDICTIONS WHERE IMPLIED WARRANTIES MAY NOT BE DISCLAIMED, ANY IMPLIED WARRANTY IS LIMITED IN DURATION TO THE DURATION OF THE EXPRESS WARRANTIES DESCRIBED IN THIS WARRANTY STATEMENT. SOME STATES DO NOT ALLOW LIMITATIONS ON HOW LONG AN IMPLIED WARRANTY LASTS, SO THE ABOVE LIMITATIONS MAY NOT APPLY TO YOU.

THE REPAIR OR REPLACEMENT OF PARTS OR THE PERFORMANCE OF SERVICE UNDER THIS WARRANTY DOES NOT EXTEND THE LIFE OF THIS WARRANTY BEYOND ITS ORIGINAL EXPIRATION DATE.

**THE WARRANTIES SET FORTH HEREIN ARE THE ONLY WARRANTIES MADE BY STEYR MOTORS WITH RESPECT TO THE PRODUCT APART FROM ANY MANDATORY RIGHTS GRANTED BY LAW IN YOUR COUNTRY. NO AUTHORIZED STEYR MOTORS PARTNER IS AUTHORIZED TO MAKE ANY ADDITIONAL WARRANTY, PROMISE, OR REPRESENTATION ON BEHALF OF STEYR MOTORS OR TO MODIFY OR EXTEND THE TERMS OR DURATION OF THIS WARRANTY.**

Some states do not allow the exclusion or limitation of incidental or consequential damages, so the above limitation or exclusion may not apply to you.

This warranty gives you specific legal rights; you may also have other rights that vary from state to state.



## **Warranty Claim Procedure**

Warranty service may be obtained from any authorized Steyr Motors partner. For a list please refer to Steyr Motors website at [www.steyr-motors.com](http://www.steyr-motors.com).

In the event of a Warrantable Failure arising during the applicable Warranty period, a Warranty claim must be submitted to an authorized Steyr Motors partner immediately upon discovery of facts that would lead a reasonably prudent owner to believe that the Product is defective.

ALL WARRANTY CLAIMS MUST BE APPROVED BY STEYR MOTORS BEFORE ANY WARRANTY WORK IS PERFORMED. No authorized Steyr Motors partner is authorized to approve, or to guarantee approval of a Warranty claim. Any work performed prior to obtaining authorization from Steyr Motors will be at the risk of the authorized Steyr Motors partner undertaking the work.

## **Miscellaneous**

This Warranty document consists of the complete and final expression of the intent of the parties with respect to the Warranty obligations of Steyr Motors. The terms of this Warranty may only be modified in writing by Steyr Motors. Steyr Motors partners (whether or not approved by Steyr Motors) are not considered as legal agents of Steyr Motors and have no authority to alter the terms of this Warranty or to waive any condition or requirement stated herein.

Steyr Motors may in certain circumstances, and at its sole discretion, provide for service outside the scope of this Warranty to update, modify, or repair a Product. In that event, Steyr Motors shall not be deemed to have assumed any additional obligation to the owner or to have modified or waived any of the provisions of this Warranty.

Any Steyr Motors Product or part replaced under Warranty will on Steyr Motors' discretion become property of Steyr Motors.





**Steyr Motors Betriebs GmbH**

Im Stadtgut B1 | A-4407 Steyr-Gleink | Austria

[www.steyr-motors.com](http://www.steyr-motors.com)