

# Installation Manual

MARINE SE

4 Cylinder / 6 Cylinder

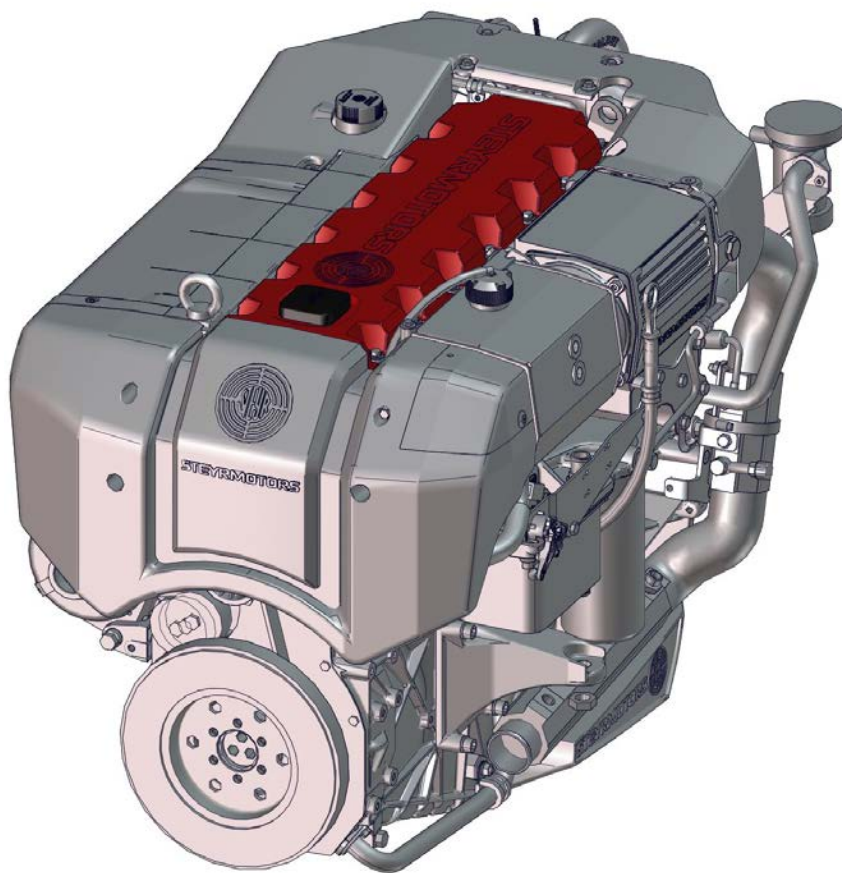

Order number	707519
Edition	2
Language	EN
Date	November 2024



## PREFACE

**Steyr Motors AG** develops high-performance diesel engines with modulated high pressure direct injection, especially for marine. **Steyr Motors** engines are designed to be adapted to various propulsion systems.

This **INSTALLATION MANUAL** is published with the main intention -

to provide information in the form of technical data and know-how based on our experience in the diesel engine business, which will enable you to install the engines:

# MARINE SE

4 Cylinder		6 Cylinder	
SE144E38	SE126E32	SE236E40	SE266S36
SE164E40	SE156E34	SE236S36	SE286E40
	SE186E38	SE266E40	SE306J38

to maintain their operating safety and reliability.

To achieve continuous improvement with regard to the format and content of the information provided, we would like to hear from you.

We, therefore, would much appreciate your comment to the following questions -

- What mistakes have you noticed?
- What information was not in the manual?
- Suggestions for improvement in general?

Please address your comment to:



		from home country	from foreign countries
<b>ADR</b> Steyr Motors AG Customer Service  Im Stadtgut B1 4407 STEYR, AUSTRIA	<b>TEL</b>  <b>@</b>	07252/222/52	+43/7252/222/52
		<a href="mailto:technical@steyr-motors.com">technical@steyr-motors.com</a> <a href="https://www.steyr-motors.com">https://www.steyr-motors.com</a>	



### **There are three main purposes in publishing this book:**

- To assist in the selection of suitable engines and auxiliary equipment for marine craft.
- To provide information in the form of technical data and installation „know - how“ built up from our marine diesel engine experience.
- To enable 6 cylinder Steyr Motors marine SE engines to be installed in a manner which will ensure safety, reliability and ease of servicing.

Make sure to comply with all laws and regulations valid in the country of operation and for the respective type of boat.

It is particularly important, to ensure that the engine installation complies with the Health and Safety Legalization of the country of intended operation.

Before starting work, make a detailed plan, use true scale drawings and consider all assembly data available.

To guarantee a proper function of the engine and its built-on parts, the correct installation is of utmost importance. These works are to be carried out with the greatest care. Make sure prior to assembly that true scale drawings and installation data are available, which will enable you to realize a satisfactory technical pre-planning and installation.

The engine compartment is to be designed in such a way that maintenance work on the engine will not be impeded. Consult the Operating Manual of the engine and the drawings. There should also be enough space to permit an inward and outward lifting of the engine.

The installation is to be done in such a way that the engine is easily accessible for regular maintenance, in order to avoid unnecessary maintenance costs for the owner.

### **Product description, illustration and technical data**

When reference is made in this manual to a brand name, a product number, a product or specific tool, an equivalent product may be used in place of the product or tool referred to, unless specifically stated otherwise. To exclude any possible danger, the operator has to provide for respective safety precautions.

All data, illustrations and specifications in this manual are based on the latest product data available at the time of printing. But it cannot be guaranteed that this manual will always be up to date. Revised versions with a later date of edition will replace all previous editions.

**Warranty** This may be invalidated if the engine is not installed, operated, or maintained according to **Steyr Motors** instructions.

**The illustrations in this manual do not always exactly represent the actual equipment or components, and serve first of all as a reference.**

**Steyr Motors AG reserves the right to make changes at any time, without notice, as to technical data or models, and also to discontinue certain models. Steyr Motors AG also reserves the right to change any technical data or components at any time, without incurring any obligation to equip the same on models manufactured prior to the date of such change.**

## TABLE OF CONTENTS

### SAFETY

### GENERAL

- 01 GENERAL INFORMATION ON INSTALLATION
- 02 WEIGTH-DISTRIBUTION BALANCE
- 03 SPECIFICATIONS
- 04 TRANSPORT AND STORAGE
- 05 QUALITY DIRECTIVES FOR ASSEMBLY
- 06 VARIANTS ENGINE - PROPULSION
- 07 ENGINE INSTALLATION
- 08 COOLING SYSTEM
- 09 FUEL SYSTEM
- 10 EXHAUST SYSTEM
- 11 AIR INTAKE AND VENTILATION
- 12 EXTERNAL CONSUMERS
- 13 SAFETY COVERS
- 14 BILGE PUMPS
- 15 CABIN HEATING
- 16 NOISE ATTENUATION
- 17 CONTROL STATION
- 18 ELECTRICAL EQUIPMENT AND INSTRUMENTS
- 19 COMMISSIONING OF INSTALLATION
- 20 APPENDIX
- 21 OPERATING AND AUXILIARY MATERIALS

**VERSIONS OF MANUAL**

<b>Version</b>	<b>Date</b>	<b>Modification</b>
1.0	01.2021	New edition
1.1	05.2021	Update
2.0	06.2024	Updated section Propeller selection in chapter "Appendix".
	08.11.2024	Updated "Steyr Motors Betriebs GmbH" to "Steyr Motors AG" and "SMB" to "SMO"  Removed engine mounted fuel system from views

---

## Table of Contents

<b>A</b>	<b>General</b> .....	<b>15</b>
<b>A 1</b>	<b>Regulations</b> .....	<b>15</b>
A 1.1	Limited application.....	15
A 1.2	Emission-related installation instructions.....	15
<b>A 2</b>	<b>Responsibilities of boat owners</b> .....	<b>16</b>
<b>S</b>	<b>Safety</b> .....	<b>17</b>
S.0.1	Additional notices.....	18
<b>S 1</b>	<b>Safety precautions</b> .....	<b>19</b>
S 1.1	Introduction.....	19
S 1.2	General information on safety.....	22
<b>S 2</b>	<b>Customer's responsibility</b> .....	<b>23</b>
<b>S 3</b>	<b>Intended (appropriate) use</b> .....	<b>24</b>
<b>S 4</b>	<b>Personnel requirements</b> .....	<b>25</b>
S 4.1	Qualification.....	25
<b>S 5</b>	<b>Safety at work</b> .....	<b>26</b>
<b>S 6</b>	<b>Personal protective equipment</b> .....	<b>29</b>
<b>S 7</b>	<b>Noise</b> .....	<b>31</b>
<b>S 8</b>	<b>Exhaust gas</b> .....	<b>32</b>
<b>S 9</b>	<b>Operating and auxiliary material</b> .....	<b>33</b>
<b>S 10</b>	<b>Electrical energy</b> .....	<b>34</b>
<b>S 11</b>	<b>Maintenance</b> .....	<b>35</b>
<b>S 12</b>	<b>Behaviour in case of danger and accidents</b> .....	<b>36</b>
<b>S 13</b>	<b>Cleanliness at the workplace</b> .....	<b>37</b>
<b>S 14</b>	<b>Environmental protection</b> .....	<b>38</b>
<b>S 15</b>	<b>Operating conditions</b> .....	<b>39</b>
S 15.1	Operating.....	39
S 15.2	Different operating behaviour.....	39
S 15.3	Technical perfect condition of the engine.....	40
S 15.4	Keep protective equipment functional.....	40
S 15.5	Unsuitable operating fluids.....	40
S 15.6	Poisonous exhaust gases.....	40
S 15.7	Complying with technical limit values.....	40

## Table of Contents

---

<b>S 16</b>	<b>Sticker overview .....</b>	<b>41</b>
S 16.1	Warning sticker .....	41
S 16.2	Sticker overview 6 cylinder engine .....	42
S 16.3	Sticker overview 4 cylinder engine .....	43
<b>1.</b>	<b>General information on installation.....</b>	<b>45</b>
<b>1.1</b>	<b>Model and serial numbers .....</b>	<b>45</b>
1.1.1	Serial number 6 cylinder engine .....	45
1.1.2	Serial number 4 cylinder engine .....	46
1.1.3	Serial number gear box .....	46
<b>1.2</b>	<b>Documentation .....</b>	<b>47</b>
<b>1.3</b>	<b>Technical data and overview .....</b>	<b>48</b>
1.3.1	Technical data 6 cylinder engine (from year of manufacture 2021) .....	48
1.3.2	Technical data 6 cylinder engine.....	49
1.3.3	Overview 6 cylinder engine.....	51
1.3.4	Dimensions 6 cylinder engine.....	54
1.3.5	Technical data 4 cylinder engine (from year of manufacture 2021) .....	55
1.3.6	Overview 4 cylinder engine.....	56
1.3.7	Dimensions 4 cylinder engine.....	59
1.3.8	Sensors and actuators overview.....	60
<b>2.</b>	<b>Weight-distribution balance.....</b>	<b>61</b>
<b>2.1</b>	<b>Accessibility.....</b>	<b>61</b>
<b>2.2</b>	<b>Displacement of water .....</b>	<b>63</b>
2.2.1	Examples for block coefficient .....	64
<b>2.3</b>	<b>List of operating materials.....</b>	<b>64</b>
<b>2.4</b>	<b>Disposal of operating materials .....</b>	<b>64</b>
<b>2.5</b>	<b>SI - system.....</b>	<b>65</b>
2.5.1	Conversion table SI - US .....	67
<b>2.6</b>	<b>Abbreviations.....</b>	<b>68</b>
<b>2.7</b>	<b>Notes on safety .....</b>	<b>68</b>
2.7.1	General notes on safety.....	70
2.7.2	Guidelines for damage prevention.....	70
2.7.3	Legal rules .....	70
2.7.4	Safety in the use of operating material .....	71
<b>2.8</b>	<b>Measures in case of accidents.....</b>	<b>72</b>

---

<b>3</b>	<b>Specifications</b> .....	<b>73</b>
<b>3.1</b>	<b>Fuel requirements</b> .....	<b>73</b>
3.1.1	How to select fuel .....	73
<b>3.2</b>	<b>Engine oil requirements</b> .....	<b>74</b>
<b>3.3</b>	<b>Engine coolant requirements</b> .....	<b>76</b>
<b>4</b>	<b>Transport and storage</b> .....	<b>77</b>
<b>4.1</b>	<b>Transport inspection</b> .....	<b>78</b>
<b>4.2</b>	<b>Packing</b> .....	<b>79</b>
4.2.1	Concerning packing .....	79
4.2.2	Handling packing materials.....	79
<b>4.3</b>	<b>Transport</b> .....	<b>80</b>
<b>4.4</b>	<b>Storage</b> .....	<b>82</b>
4.4.1	Storage conditions .....	82
4.4.2	Start-up after storage.....	83
<b>4.5</b>	<b>Extended storage preservation procedure</b> .....	<b>84</b>
4.5.1	Preservation.....	85
4.5.1.1	1 <sup>st</sup> Preservation procedure.....	85
4.5.2	2 <sup>nd</sup> Preservation .....	91
4.5.3	De-preservation .....	92
4.5.3.1	De-preservation .....	92
4.5.3.2	De-preservation procedure .....	93
<b>5</b>	<b>Quality directives for assembly</b> .....	<b>95</b>
<b>5.1</b>	<b>Specification of spare parts</b> .....	<b>95</b>
<b>5.2</b>	<b>Workshop profile</b> .....	<b>96</b>
<b>5.3</b>	<b>Assembly of plug connections</b> .....	<b>97</b>
5.3.1	Plug connections for steel tube.....	97
5.3.2	Plug connection for plastic tube.....	98
5.3.3	Checking of plug connections.....	98
5.3.4	Assembly of Raufoss plug systems .....	98
5.3.5	Sealing of screwed pipe joints .....	99
5.3.6	Tightening torques .....	99
5.3.7	Pipe relaying .....	100
<b>5.4</b>	<b>Electrical connections</b> .....	<b>101</b>
5.4.1	Tightening torques for electrical connections .....	104

---

<b>5.5</b>	<b>Tightening torques .....</b>	<b>105</b>
<b>5.5.1</b>	<b>Checking of torque wrench .....</b>	<b>105</b>
<b>5.6</b>	<b>Nondestructive testing of materials .....</b>	<b>106</b>
<b>5.7</b>	<b>Use of adhesive and sealing materials.....</b>	<b>106</b>
<b>5.8</b>	<b>Solvent free sealing materials.....</b>	<b>107</b>
5.8.1	General directions for use of anaerobic sealing materials.....	107
<b>6</b>	<b>Variants engine propulsion .....</b>	<b>109</b>
<b>6.1</b>	<b>6 cylinder engines .....</b>	<b>109</b>
6.1.1	Bobtail - Version.....	109
6.1.2	Down angle.....	109
6.1.3	Lifeboat engine .....	110
6.1.4	Jet drive .....	111
6.1.6	Stern drive .....	112
<b>6.2</b>	<b>4 cylinder engines .....</b>	<b>113</b>
6.2.1	Bobtail - Version.....	113
6.2.2	Down angle.....	113
6.2.3	Lifeboat engine .....	114
6.2.4	Jet drive .....	115
6.2.5	Stern drive .....	116
<b>6.3</b>	<b>Emission relevant components .....</b>	<b>117</b>
<b>7</b>	<b>Engine installation .....</b>	<b>119</b>
<b>7.1</b>	<b>Foundation .....</b>	<b>119</b>
<b>7.2</b>	<b>Power transmission .....</b>	<b>120</b>
7.2.1	Coupling.....	120
7.2.2	Universal joint shafts.....	121
7.2.3	Additional cooling circuit on engine .....	122
<b>7.3</b>	<b>Engine base .....</b>	<b>122</b>
7.3.1	Engine base on synthetic boats.....	122
<b>7.4</b>	<b>Space for maintenance .....</b>	<b>123</b>
<b>7.5</b>	<b>Engine inclination.....</b>	<b>124</b>
<b>7.6</b>	<b>Lifting eyes.....</b>	<b>125</b>
<b>7.7</b>	<b>Checking of engine base .....</b>	<b>126</b>
<b>7.8</b>	<b>Propeller shaft flange.....</b>	<b>127</b>

---

<b>7.9</b>	<b>Engine mounts</b> .....	<b>128</b>
7.9.1	Adjustment of engine on flexible engine mounts .....	129
<b>7.10</b>	<b>Elastic shaft coupling</b> .....	<b>129</b>
<b>7.11</b>	<b>Step bearing</b> .....	<b>130</b>
<b>7.12</b>	<b>Adjustment of engine drive unit</b> .....	<b>131</b>
<b>7.13</b>	<b>Twin installation</b> .....	<b>132</b>
<b>7.14</b>	<b>Shaft and stem tube</b> .....	<b>133</b>
<b>7.15</b>	<b>Propeller</b> .....	<b>134</b>
7.15.1	Dimensions .....	134
7.15.2	Propeller pitch.....	135
7.15.3	Blade surface.....	135
7.15.4	Sense of rotation.....	135
7.15.5	Number of blades .....	136
7.15.6	Axle hub.....	136
7.15.7	Adjustment of propeller pitch .....	136
7.15.8	Space between propeller and boat.....	137
7.15.9	Sediments.....	137
7.15.10	Choice of propeller.....	137
7.15.11	Cavitation.....	139
<b>7.16</b>	<b>Propeller - thrust bearing resp. step bearing</b> .....	<b>139</b>
<b>8</b>	<b>Cooling system</b> .....	<b>141</b>
<b>8.1</b>	<b>General</b> .....	<b>141</b>
<b>8.2</b>	<b>Raw water pick up and bottom valve</b> .....	<b>141</b>
<b>8.3</b>	<b>Raw water filter</b> .....	<b>143</b>
<b>8.4</b>	<b>Raw water pipe</b> .....	<b>143</b>
<b>8.5</b>	<b>Exhaust connection</b> .....	<b>144</b>
<b>8.6</b>	<b>Additional cooling circuits on engines</b> .....	<b>145</b>
8.6.1	Standard gear box cooling from Steyr Motors .....	145
<b>8.7</b>	<b>Scheme of raw water cooling with gear box</b> .....	<b>145</b>
<b>8.8</b>	<b>Scheme of raw water cooling with stern drive</b> .....	<b>146</b>
<b>8.9</b>	<b>Scheme of raw water cooling with jet drive</b> .....	<b>147</b>
<b>8.10</b>	<b>Scheme of cooling with keel cooler</b> .....	<b>148</b>
8.10.1	Keel cooling dimensioning .....	150

---

## Table of Contents

---

<b>9</b>	<b>Fuel system .....</b>	<b>151</b>
<b>9.1</b>	<b>General .....</b>	<b>151</b>
<b>9.2</b>	<b>Fuel tank(s) .....</b>	<b>153</b>
<b>9.3</b>	<b>Twin fuel tanks .....</b>	<b>155</b>
<b>9.4</b>	<b>Fuel pipes .....</b>	<b>156</b>
<b>10</b>	<b>Exhaust system.....</b>	<b>159</b>
<b>10.1</b>	<b>General .....</b>	<b>159</b>
<b>10.2</b>	<b>Materials .....</b>	<b>159</b>
<b>10.3</b>	<b>Dry exhaust pipe.....</b>	<b>160</b>
<b>10.4</b>	<b>Wet exhaust pipe .....</b>	<b>161</b>
10.4.1	Exhaust for inboard engines above water line.....	162
10.4.2	Exhaust for inboard engines below water line .....	163
10.4.3	Exhaust for stern drive engines .....	165
<b>10.5</b>	<b>Dimensions for exhaust pipe connection .....</b>	<b>166</b>
10.5.1	Wet exhaust pipe .....	166
10.5.2	Measuring of back pressure .....	169
<b>10.6</b>	<b>Condensed-water collector .....</b>	<b>169</b>
<b>11</b>	<b>Air intake and ventilation .....</b>	<b>171</b>
<b>11.1</b>	<b>General .....</b>	<b>171</b>
<b>11.2</b>	<b>Design requirements.....</b>	<b>172</b>
<b>11.3</b>	<b>Temperature requirements .....</b>	<b>172</b>
<b>11.4</b>	<b>Calculation of air quantity, ventilation and fan-blast .....</b>	<b>173</b>
<b>11.5</b>	<b>Example for air inlet and ventilation.....</b>	<b>175</b>
<b>12</b>	<b>External consumers.....</b>	<b>177</b>
<b>13</b>	<b>Safety instructions.....</b>	<b>179</b>
<b>14</b>	<b>Bilge pumps.....</b>	<b>181</b>
<b>15</b>	<b>Cabin heating .....</b>	<b>183</b>
<b>15.1</b>	<b>Separate heating.....</b>	<b>183</b>
<b>15.2</b>	<b>Cabin heating, connected to engine.....</b>	<b>183</b>
<b>16</b>	<b>Noise attenuation .....</b>	<b>185</b>
<b>16.1</b>	<b>General .....</b>	<b>185</b>
<b>16.2</b>	<b>Noise reduction .....</b>	<b>186</b>

---

<b>16.3</b>	<b>Noise absorbing hoods as superstructure .....</b>	<b>188</b>
<b>16.4</b>	<b>Noise-absorbing material .....</b>	<b>188</b>
<b>17</b>	<b>Control station.....</b>	<b>189</b>
<b>17.1</b>	<b>General .....</b>	<b>189</b>
<b>17.2</b>	<b>Control systems .....</b>	<b>191</b>
17.2.1	Mechanical control.....	191
17.2.2	Hydraulic control .....	191
17.2.3	Electronic control .....	192
<b>17.3</b>	<b>Control levers .....</b>	<b>194</b>
17.3.1	Kinds of control levers .....	194
17.3.2	Possible functions of control lever .....	194
<b>17.4</b>	<b>Control cable.....</b>	<b>195</b>
<b>17.5</b>	<b>Control stations .....</b>	<b>196</b>
<b>17.6</b>	<b>Instrument panels.....</b>	<b>197</b>
17.6.1	Scheme for instrument panel and SCC2 .....	197
17.6.2	Scheme for instrument panel and SCC2 with GPS .....	198
<b>17.7</b>	<b>Cut out drawings .....</b>	<b>199</b>
17.7.1	Cut out drawing for instrument panel (standard) / instrument panel SOLAS.....	199
17.7.2	Cut out drawing for SCC key ignition panel/push button ignition panel (SOLAS)	201
17.7.3	Cut out drawing for SCC2.....	202
<b>18</b>	<b>Electrical equipment .....</b>	<b>203</b>
<b>18.1</b>	<b>General .....</b>	<b>203</b>
<b>18.2</b>	<b>Batteries .....</b>	<b>203</b>
<b>18.3</b>	<b>Battery cable lengths and cross-section .....</b>	<b>205</b>
<b>18.4</b>	<b>Additional current utilization devices.....</b>	<b>206</b>
<b>18.5</b>	<b>Calculation of cable cross-section for additional equipment ....</b>	<b>207</b>
<b>18.6</b>	<b>Cable cross-section .....</b>	<b>207</b>
<b>19</b>	<b>Commissioning of installation.....</b>	<b>209</b>
<b>20</b>	<b>Appendix.....</b>	<b>211</b>
<b>20.1</b>	<b>Drill templates.....</b>	<b>211</b>
<b>20.2</b>	<b>Propeller calculation form .....</b>	<b>212</b>
<b>20.3</b>	<b>Installation guide .....</b>	<b>213</b>
20.3.1	Engine base must.....	213

---

## Table of Contents

---

21.3.2	Engine mounts.....	213
20.3.3	Lifting points.....	214
20.3.4	Space for maintenance.....	214
20.3.5	Engine angle.....	215
20.3.6	Air and ventilation .....	215
20.3.7	Raw water .....	216
20.3.8	Clean fuel.....	216
20.3.9	Exhaust system .....	217
20.3.10	Inboard installation.....	218
20.3.11	Stern drive installation .....	219
20.3.12	Propeller selection .....	220
<b>21</b>	<b>Operating and auxiliary materials .....</b>	<b>221</b>

## A General

The installation of a marine engine is a very comprehensive task to be carried out with greatest care and attention. Before beginning, plan the execution and the works very carefully.

There should be space for the following components:

Control, manoeuvring apparatus, instrument panel with laced wiring harness, fuel tanks, pipings, batteries, engine compartment blower, air-vent conduits, exhaust systems, access to service and maintenance items.

Special attention is required to provide a proper installation environment, cooling and venting for electric and electronic equipment, as well as accumulating systems according to manufacturer specifications of used items.

Don't forget that the engine compartment, the tank compartment and the battery box must be separated from each other to reduce the danger of fire. In addition, separate fire extinguishers must be available (e. g. in the pantry) depending on boat size and type.

### A 1 Regulations

Note that each country has its own safety regulations regarding installation. Therefore, it is necessary, that the boat-builder/engine fitter is aware of the local safety regulations, before beginning works.

#### A 1.1 Limited application

Ship-owners or boat builders installing a Steyr Motors marine engine in a vessel which will be used in ECA (Emission Control Areas) and which are not excluded from IMO Tier III in accordance with Annex VI regulation 13.1.2, must contact the EPA and the US Coast Guard to verify that the boat has an exception from IMO Tier III in accordance with Annex VI Regulation 13.5.2.2. using engines with an EPA Tier 3 / IMO MARPOL 73/78 Tier II approval.

#### A 1.2 Emission-related installation instructions

Failing to follow these instructions when installing a certified engine in a vessel violates federal law (40 CFR 1068.105(b)), subject to fines or other penalties as described in the Clean Air Act.

The exhaust system has to be installed according to the installation instruction, *refer to 10.3 Dry exhaust pipe.*

For engine diagnostics use the Steyr Motors Engine diagnostic tool (EDT). The EDT user manual is integrated in the EDT-Help. (<https://www.steyr-motors.com> latest version assured).

### Limited application

- see A1.1
- Accepted applications
  - Variable Speed - Propulsion - Fixed Pitch Propeller
  - Variable Speed - Auxiliary - Propeller Law

If you install the engine in a way that makes the engine's emission control information label hard to read during normal engine maintenance, you must place a duplicate label on the vessel, as described in 40 CFR 1068.105.

---

### **NOTICE**

If the engine emission control label is obscured while installing the engine in the vessel such that the label will be hard to read or not readable during normal maintenance, a duplicate label has to be placed on the vessel.

A duplicate of this label has to be requested from Steyr Motors to be placed on the vessel in a clearly visible position.

---

## **A 2 Responsibilities of boat owners**

As a boat owner, you have certain responsibilities to others.

You are legally responsible for all occupants of your boat. Show all assistants the location of the emergency equipment and how to use it. You are required by law to have aboard one proper life jacket for each person, plus one approved, throwable device for man overboard protection.

Learn the local waterway rules for boats and ships. Navigable waterways are controlled by Federal regulations. Obey these regulations to protect yourself, your passengers and your fellow boating enthusiasts.

Thoroughly familiarize yourself with weather station warning systems and waterway nautical signals.

Contact your local Coast Guard station and take advantage of their seasonal boat inspections and training courses.

The manner and circumstances of the application, installation and use of the engine is not under the direct control of **Steyr Motors** and **Steyr Motors** cannot be held liable for any loss or damage where the installer or user has not followed advice given by the manufacturer.

## S Safety

This manual contains certain information related to the personal safety of you as the operator, your passengers, bystanders and other persons.

**Steyr Motors AG** is concerned about your safety and the condition of your engine. The safety instructions will alert you to potential hazards associated with installing **Steyr Motors** engines.

This chapter provides an overview of all important safety aspects for optimal protection of personnel as well as safe and trouble-free operation. Inappropriate behaviour and insufficient knowledge of hazards during works may cause personal injury.

Non-observance of these safety instructions and safety regulations can result in considerable danger. In the description of works, such sources of danger are marked with one of the three following symbols:



### **DANGER**

**DANGER** indicates a hazardous situation which, if not avoided, will result in death or serious injury!

Possible consequences by non-observance.

▶ How to avoid injuries.

---



### **WARNING**

**WARNING** indicates a hazardous situation which, if not avoided, could result in death or serious injury!

Possible consequences by non-observance.

▶ How to avoid injuries.

---



### **CAUTION**

**CAUTION** indicates a hazardous situation which, if not avoided, could result in minor or moderate injury!

Possible consequences by non-observance.

▶ How to avoid injuries.

---

### **Property damage to the engine**

---

### **NOTICE**

NOTICE indicates a potentially hazardous situation, if not avoided, could result in damage to the engine.

▶ How to avoid damages.

---

#### **S.0.1 Additional notices**

---

##### **Information**

Indicates an information which compliance results in a more efficient and more economical use of the engine.

---

##### **Environment**

Indicates a note which compliance results in a proper handling of environmentally hazardous substances.

---

## S 1 Safety precautions

### S 1.1 Introduction

Read the book carefully before operating or servicing the engine. Incorrect operation or servicing of the engine could result in personal injury or material damage as well as damaging the engine itself. If you do not understand or are uncertain on any operation in this book, contact your dealer who can explain or demonstrate the procedure for you.

Before starting work on the engine, read the “Safety precautions” of this manual carefully.



Immobilize the engine by turning off the power supply to the engine at the main switch (switches/breakers) and lock it (them) in the OFF position before starting work. Set up a warning notice at the engine control point or helm.

As a general rule all service operations must be carried out with the engine stopped. However, some work, for example certain adjustments require that the engine is running when they are carried out.

Approaching an engine which is operating is a safety risk. Loose clothing or long hair can fasten in rotating parts and cause serious personal injury. If working in proximity of an engine which is operating, careless movements or a dropped tool can result in personal injury.

Take care to avoid contact with hot surfaces (exhaust pipes, turbocharger, air intake pipe, start element etc.) and hot liquids in lines and hoses on an engine which is running or which has just been stopped. Reinstall all protective parts removed during service operations before starting the engine.



Check that the warning or information labels on the engine are always clearly visible. Replace labels which have been damaged or painted over.



Engines with turbocharger: Never start the engine without installing the air cleaner filter. The rotating compressor in the turbo can cause serious personal injury. Foreign objects entering the intake ducts can also cause mechanical damage.

Never use start spray products or similar when starting the engine. They may cause an explosion in the inlet manifold. Danger of personal injury.



Avoid opening the filler cap for engine coolant system (freshwater cooled engines) when the engine is still hot. Steam or hot coolant can spray out. Open the filler cap slowly and release the pressure in the system. Take great care if a cock, plug or engine coolant line must be removed from a hot engine. Steam or hot coolant can spray out in any direction.

Hot oil can cause burns. Avoid getting hot oil on the skin. Ensure that the lubrication system is not under pressure before carrying out any work. Never start or operate the engine with the oil filler cap removed, otherwise oil could be ejected.



Stop the engine and close the sea cock before carrying out operations on the engine cooling system.



Only start the engine in a well-ventilated area. If operating the engine in an enclosed area ensure that there is exhaust ventilation leading out of the engine compartment or workshop area to remove exhaust gases and crankcase ventilation emissions.

Always use protective glasses or goggles when carrying out work where there is a risk of splinters, grinding sparks, acid splashes or where other chemicals are used. The eyes are extremely sensitive, an injury could result in blindness!



Avoid getting oil on the skin! Repeated exposure to oil or exposure over a long period can result in the skin becoming dry. Irritation, dryness and eczema and other skin problems can then occur. Used oil is more dangerous than fresh oil from a health aspect. Use protective gloves and avoid oil soaked clothes and shop rags. Wash regularly, especially before eating. There are special skin creams which counteract drying out of the skin and make it easier to clean off dirt after work is completed.

Many chemicals used on the product (for example engine and transmission oils, glycol, gasoline and diesel oil), or chemicals used in the workshop (for example degreasing agents, paint and solvents) are dangerous to health. Read the instructions on the product packaging carefully! Always follow the safety precautions for the product (for example use of protective mask, glasses, gloves etc.). Make sure that other personnel are not exposed to hazardous chemicals, for example in the air. Ensure good ventilation in the work place. Follow the instructions provided when disposing of used or leftover chemicals.



Exercise extreme care when leak detecting on the fuel system and testing the fuel injector jets. Use eye protection. The jet from a fuel injector nozzle is under extremely high pressure and has great penetrative energy, so the fuel can penetrate deep into the body tissue and cause serious personal injury. Danger of blood poisoning.



All fuels and many chemical substances are flammable. Do not allow naked flame or sparks in the vicinity. Fuel, certain thinner products and hydrogen from batteries can be extremely flammable and explosive when mixed with air.

Smoking is not to be permitted in the vicinity!

Ensure that the work area is well ventilated and take the necessary safety precautions before starting welding or grinding work. Always ensure that there are fire extinguishers at hand when work is being carried out.



Ensure that rags soaked in oil or fuel and used fuel or oil filters are stored safely. Rags soaked in oil can spontaneously ignite under certain circumstances. Used fuel and oil filters are environmentally dangerous waste and must be deposited at an approved site for destruction together with used lubricating oil, contaminated fuel, paint remnants, solvent, degreasing agents and waste from washing parts.

Never expose a battery to naked flame or electrical sparks. Never smoke in proximity to the batteries. The batteries give off hydrogen gas during charging which when mixed with air can form an explosive gas -oxyhydrogen. This gas is easily ignited and highly volatile. Incorrect connection of the battery can cause a single spark which is sufficient to cause an explosion with resulting damage. Do not shift the connections when attempting to start the engine (spark risk) and do not lean over any of the batteries.



Always ensure that the Plus [+ (positive)] and Minus [- (negative)] battery leads are correctly installed on the corresponding terminal posts on the batteries. Incorrect installation can result in serious damage to the electrical equipment. Refer to the wiring diagrams.



Always use protective goggles when charging and handling the batteries. Battery electrolyte contains sulphuric acid which is highly corrosive. Should the battery electrolyte come into contact with unprotected skin wash off immediately using plenty of water and soap. If battery acid comes in contact with the eyes, immediately flush with plenty of water and obtain medical assistance at once.



Turn the engine off and turn off the power at the main switch(es) before carrying out work on the electrical system.

Clutch adjustments must be carried out with the engine stopped.

### S 1.2 General information on safety

#### Guidelines for damage prevention

This section does not include the scope of general knowledge and the training of material maintenance personnel as well as the “general rules of safety technics” and machine safety regulations - MSV.

Inappropriate behaviour and the ignorance of material maintenance may result in considerable material damages.

While operating with fuel and oil, take care not to apply them on the surface of optical systems.

Lubricants should form a thin film on the surface, surplus lubricants must be removed.

#### Legal rules

The following rules and guidelines are valid in Austria. For other countries, follow the local regulations.

## S 2 Customer's responsibility

The engine is only used in the commercial field of usage. The owner of the engine is subject to the legal obligations for health and safety at work. As well as the operational safety instructions in this manual, the applicable safety, accident prevention and environmental regulations for the application must also be complied with. The following particularly apply:

- The owner must inform himself about the applicable health and safety conditions and also determine hazards arising from the special operating conditions at the usage location of the engine in a risk analysis. He must implement this in the form of operating instructions, e.g. service manual.
- The owner must check during the entire period of use of the engine whether the operating instructions he has produced comply with the current state of the regulations and adapt them if necessary.
- The owner must clearly regulate and specify the responsibilities for installation, operation, maintenance and cleaning.
- The owner must ensure that all employees involved with the engine have read and understood the operating instructions. He must also train the personnel and inform them about the dangers at regular intervals.
- The owner must provide the necessary protective equipment for the personnel.

The owner is also responsible that the engine is always in proper working condition. Therefore, strictly observe the following:

- The owner must ensure that the maintenance intervals specified in this manual are complied with.
- The owner must arrange for all safety equipment to be checked regularly for functionality and completeness.
- Explosive and easily flammable substances must always be kept away from the engine as the engine can become very hot during operation.
- Do not touch rotating parts while the engine is running.
- Only fill with fuel when the engine is switched off. Do not fill in the vicinity of naked flames or ignitable sparks, do not smoke and do not spill any fuel.
- This manual must be kept in the immediate vicinity of the engine and must be accessible at any time to all persons working on and with the engine.
- In the case of doubt, always contact Steyr Motors AG before starting the engine.
- The engine must only be operated if it is in proper working condition. The engine must be checked for intactness before every start-up.
- Only regular maintenance in accordance with the information in this manual maintains the operational readiness of the engine - otherwise loss of warranty.
- Only perform maintenance and cleaning work when the engine is out of operation.
- Strictly observe all the information in the manual.
- Always keep the engine in a good condition. Unauthorized modifications have a negative effect on functioning and/or safe operation as well as the service life.
- Any variations from the operating conditions that are defined in the technical data can result in premature failure of the engine lead to major damage to property (e.g. by using the wrong fuel, etc).

### S 3 Intended (appropriate) use

The engine is designed and constructed exclusively for the intended purpose described here.

The engine is provided exclusively for the intended purpose which has been specified and tested by the manufacturer of the equipment in which the engine is installed:

- With connected exhaust system
- With connected cooling system
- With connected air intake
- No modifications to the vessel following a successful Vessel Acceptance Test by Steyr Motors AG
- Within the defined load profiles
- Within the permissible ambient temperatures
- Using permitted equipment (fuel, coolant, etc.)
- Within the specified vessel mass
- While observing the storage and storage conditions
- While maintaining maintenance intervals

Any other use is considered to be improper.

**Steyr Motors AG** accepts no liability for any dangers and damage resulting from this. The risk is born solely by the user.

The installation must be made so that all applicable safety regulations for the operation of diesel engines are complied with.

Proper use also includes compliance with all the information in this operators manual.

Any use beyond the intended use and/or other types of use is considered misuse and can result in dangerous situations.

---

## S 4 Personnel requirements

### S 4.1 Qualification

---

#### **WARNING**

##### **Danger of injury for unqualified personnel!**

Improper handling can result in severe personal injuries and/or material damage.

- ▶ Have all jobs carried out by qualified personnel only.

---

The following qualifications are specified for different areas of activity listed in the manual:

- **Operator / User**  
has been instructed by the owner about the tasks assigned to him and possible dangers in the case of improper behaviour.
- **Service personnel**  
are persons who on the basis of their professional training by **Steyr Motors AG**, experience and knowledge of the relevant conditions can perform the work assigned to them using the operating, service and repair instructions and can recognise and avoid possible dangers themselves.
- Only persons who perform their tasks reliably are permitted as personnel. Persons whose reaction capability is impaired, e.g. through drugs, alcohol or medication are not permitted.
- When selecting personnel, observe the age and occupational regulations applicable at the place of employment.

### S 5 Safety at work

---

#### Follow safety instructions

Read carefully all safety instructions in this manual as well as all warning labels on the engine.

- ▶ Keep the warning stickers clean.
- ▶ Replace missing or damaged warning labels.
- ▶ Mark new components and spare parts with the currently valid warning labels.
- ▶ Replacement warning labels are available from the **Steyr Motors** dealer.

Familiarize yourself with the operation of the engine and the controls.

If you do not understand parts of this manual and need help, please contact your **Steyr Motors** dealer.

---

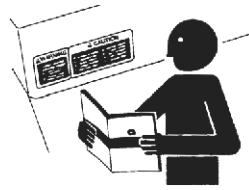

#### Risk of fire due to fuel and operating materials

Handle fuel with care: it is highly flammable.

- ▶ Always stop engine before refuelling engine.
  - ▶ Fill fuel tank outdoors.
  - ▶ Do not refuel the engine while smoking or when near open flames, sparks or other fire hazards.
  - ▶ Always clean up spilled fuel.
  - ▶ Store flammable fluids away from fire hazards.
  - ▶ Prevent fires by keeping engine clean of accumulated trash, grease and debris.
  - ▶ Do not store oily rags; they can ignite and burn spontaneously.
- 



---

### Cutting injuries by fan

Rotating cooling system fans can cause serious injury.

- ▶ Wear close fitting clothes.
  - ▶ Stop engine and be sure fan is stopped before making adjustments or connections, or cleaning near the front of the engine.
- 



---

### Avoid high-pressure fluids

Escaping fluid under pressure from high-pressure nozzles can penetrate the skin causing serious injury.

- ▶ Avoid the hazard by relieving pressure before disconnecting lines.
  - ▶ Tighten all connections before applying pressure.
  - ▶ Search for leaks with a piece of cardboard.
  - ▶ Protect hands and body from high pressure fluids.
  - ▶ Wear suitable personal protective equipment.
  - ▶ If an accident occurs, see a doctor immediately.
  - ▶ Any fluid injected into the skin must be surgically removed within a few hours or gangrene may result.
- 



---

### Use proper lifting equipment

Lifting heavy components incorrectly can cause severe injury.

- ▶ Use only approved, inspected and adequately rated lifting equipment.
  - ▶ Follow recommended procedure for removal and installation of components in the manual.
- 

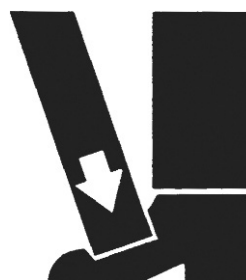

### Use only approved tools

Faulty or broken tools can result in serious injury. Makeshift tools and procedures can create safety hazards. Avoid bodily injury caused by slipping wrenches.



- ▶ When constructing tools, use proper quality materials and good workmanship.
  - ▶ Use only service parts meeting specifications.
  - ▶ For loosening and tightening hardware, use the correct size tools.
  - ▶ Only use spare parts according to specification.
-

## S 6 Personal protective equipment

The personal protective equipment must comply with the national employee protection regulations.

The operator must make the appropriate personal protective equipment available for any person who performs work on the engine and instruct them to wear it. Wearing of personal protective equipment is required when working to minimize the health hazards.

- Always wear the protective equipment that is necessary for the respective task when working.
- Follow the instructions on personal protective equipment that are posted in the work area.

Generally wear for all kind of work:

---

### Protective clothing

is close fitting, with low resistance to tearing, with narrow sleeves and without protruding parts. It mainly provides protection against being entangled by moving engine parts.

Do not wear any rings and other jewellery.

---



---

### Safety boots

to protect against heavy parts falling down or slipping on slippery ground.

---



Personal protective equipment for special tasks. When performing special tasks it is necessary to wear personal protective equipment. This personal protective equipment will be separately specified in the chapters of this Manual. This special protective equipment is explained below.

---

### Ear defenders

to protect against hearing damage.

---



---

### Hard hat, helmet

to protect against parts and materials falling down and flying around.

---



## Safety

---

---

### Protective gloves

to protect the hands against friction, graze, punctures or deep cuts as well as contact with hot surfaces.

---



---

### Safety goggles

to protect the eyes against parts flying around or squirts of fluids.

---



---

### Fine dust mask

to protect the airways against harmful dust.

---



## **S 7      Noise**

Noise can lead to an increased risk of accidents if a perception of acoustic signals, warning cries or danger announcing noise is affected by it.

Wear hearing protection (e.g. earmuffs or earplugs) at all workplaces with a sound pressure level of 85 dB(A).

Safe operation of the vessel requires the driver's full attention.

No headphones for listening to radio or music during operation.

---

### **Noise protection**

Prolonged exposure to loud noise can cause impairment or loss of hearing.

In the case of loud noises, wear suitable noise protection, e.g. ear protectors or ear plugs.

---

### **S 8 Exhaust gas**

Risk due to exhaust gases! Engine exhaust fumes can result in sickness or death!

- ▶ The exhaust emissions need to be deflected from the control station of the engine. Ensure adequate ventilation.

Follow the law applicable to the site regulations!

Only carry out welding or grinding work on the engine, if it is expressly authorized. There is risk of fire or explosion!

---

## S 9 Operating and auxiliary material

Operating materials are

- Engine oil
- Fuel
- Coolant

Auxiliary materials are those substances which are required for maintenance and repair work (e.g., glue, paste, etc.)

### **Warning - Danger of poisoning and danger of skin rashes and allergies!**

Fuels (carcinogenic) and lubricants contain substances harmful to health and can result in severe poisoning and skin rashes or allergies.

- ▶ Observe the safety data sheet of the manufacturer of fuels and lubricants.
- ▶ Avoid spills of fuel and fog.
- ▶ In the case of inhalation, bring affected person into the open air immediately. Contact a doctor.
- ▶ Contact doctor immediately in the case of swallowing. Rinse mouth thoroughly with water.
- ▶ Avoid skin and eye contact.
- ▶ Wear protective gloves made of plastic or rubber during the work.
- ▶ In the case of contact with the skin or eyes, rinse immediately with a lot of water. Contact a doctor.
- ▶ Dispose of contamination in the working area properly and in accordance with environmental regulations.
- ▶ Fuels and lubricants must not get into the sewer system.
- ▶ Do not eat, drink or smoke when working.

---

### **Safe handling of auxiliary and operating materials.**

Direct contact with hazardous materials can cause serious injuries. Material Safety Data Sheets (MSDS) provide specific information about chemicals: physical and health hazards, safety precautions, and emergency procedures.

- ▶ Read Material Safety Data Sheets before starting work with hazardous chemicals (consult your dealer for safety data sheets for chemical products used with your engine).
-

### **S 10      Electrical energy**

Work on electrical equipment may only be carried out by a qualified electrician or by instructed persons under the direction and supervision of a qualified electrician in accordance with electrotechnical regulations.

Check cable (hoses) and screw connections regularly for leaks and externally visible damages. Repair damages immediately.

In addition to the general safety instructions, local safety instructions and guidelines must be observed and respected.

## S 11 Maintenance

### Service engine safely

Loose clothing (e.g. necktie, scarf) or jewellery (e.g. necklace) can cause serious injury if these items were to get caught by moving parts.

- ▶ Tie long hair behind your head.
- ▶ Do not wear a necktie, scarf, loose clothing or necklace.
- ▶ Remove rings and other jewellery to prevent electrical shorts and entanglement in moving parts.

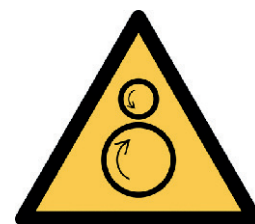
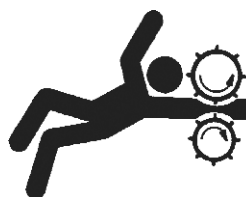

### Service cooling system safely

Explosive release of fluids from pressurized cooling system can cause serious burns.

- ▶ Shut off engine.
- ▶ Only remove filler cap when cool enough to touch with bare hands.
- ▶ Slowly loosen cap to first stop to relieve pressure before removing components.



### Practice safe maintenance

- ▶ All work may only be carried out by trained personnel.
- ▶ Understand service procedure before doing work.
- ▶ Keep area clean and dry.
- ▶ Never lubricate, service or adjust engine while it is moving.
- ▶ Keep hands, feet and clothing from power-driven parts.
- ▶ Securely support any engine elements that must be raised for service work.
- ▶ Keep all parts in good condition and properly installed.
- ▶ Repair damages immediately.
- ▶ Replace worn or broken parts.
- ▶ Remove any buildup of grease, oil or debris.

### S 12 Behaviour in case of danger and accidents

---

#### Prepare for emergencies

Preventive measures:

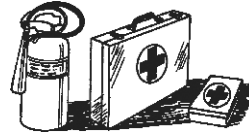

- ▶ Always be prepared for accidents or fire.
  - ▶ Keep first aid equipment (first aid kit, blankets etc.) and fire extinguishers ready at hand.
  - ▶ Keep emergency numbers for doctors, ambulance service, hospital, and fire department near your telephone.
  - ▶ Familiarise personnel with accident reporting, first aid and rescue equipment.
  - ▶ Keep access routes clear for rescue vehicles.
- 

#### Actions in case of accidents

- Operate the EMERGENCY STOP button on the engine (if present) immediately.
- Initiate first aid actions.
- Rescue people from the danger zone.
- Inform the responsible person at the usage location.
- Notify the rescue services.
- Keep access routes clear for rescue vehicles.

---

## S 13 Cleanliness at the workplace

---

### Keep workplace and engine clean.

Before starting a job:

- ▶ Clean work area and engine.
  - ▶ Make sure you have all necessary tools to do your job.
  - ▶ Have the right parts on hand.
  - ▶ Read all instructions thoroughly; do not attempt shortcuts. Unauthorized reconstruction and modification are not allowed.
- 

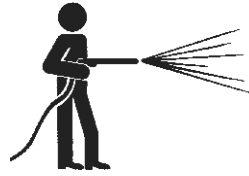

### S 14 Environmental protection

---



#### Environment

Significant environmental damage can occur, particularly from incorrect disposal, if environmentally hazardous operating materials are mishandled.

- ▶ Observe the safety data sheet from the manufacturer.
  - ▶ Dispose of waste properly.
  - ▶ Take immediate action if environmentally hazardous materials reach the environment. Inform the responsible local authorities about the damage in the case of doubt.
- 

#### Dispose of waste properly

Improperly disposing of waste can threaten the environment and ecology. Potentially harmful waste used with equipment includes such items as oil, fuel, coolant, brake fluid, filters and batteries.

- ▶ Use leakproof containers when draining fluids.
  - ▶ Do not use food or drink containers that could mislead people into drinking from them.
  - ▶ Do not pour waste onto the ground, down a drain, or into any water source.
  - ▶ Inquire on the proper way to recycle or dispose of waste from your local environmental or recycling centre, or from your dealer/Steyr Motors AG.
- 

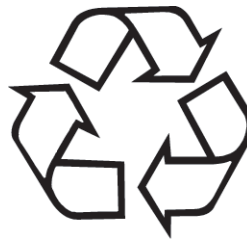

---

## S 15 Operating conditions

Any variations from the defined operating conditions can result in life-threatening injuries or even death!

- Observe operating conditions  
For further information, *refer to 1.3 Technical data and overview.*
- Observe load profile  
For further information, refer to the operation, maintenance & warranty manual.

### S 15.1 Operating

Only operate the engine if:

- the engine has been properly commissioned,
- the engine is in perfect technical condition,
- all of the covers are closed and have been installed tightly,
- there are no visible leaks,
- impurities are removed,
- a visual inspection is carried out.

### S 15.2 Different operating behaviour

You can detect changes compared to normal operation by the fact that there is a negative effect on the function of the diesel power module.

These include:

- Error light
- Unusual vibrations
- Unusual noises

The system shows the corresponding fault messages on the display.

If there are safety-relevant changes in the engine, deactivate it immediately and carry out appropriate inspections, servicing, or repair work.

If safe operation is not assured, inform the **Steyr Motors** or an authorized **Steyr Motors** service partner immediately.

### **S 15.3 Technical perfect condition of the engine**

Deficient maintenance or non-compliance with maintenance intervals can impair safe operation and result in serious or fatal injuries.

- Maintain the engine in accordance with the maintenance schedule.  
For further information, refer to the operation, maintenance & warranty manual.
- Immediately remove any possible causes of damage, for example remove coarse contaminants or tighten up loose screws.

### **S 15.4 Keep protective equipment functional**

Missing or damaged protective equipment can cause serious injury or death due to moving machine parts.

- Replace damaged protective equipment.
- Before carrying out commissioning, remount protective equipment and any other parts that have been dismantled.

### **S 15.5 Unsuitable operating fluids**

Operating fluids that do not meet the requirements of the manufacturer can compromise safe operation and cause accidents.

- Only use operating fluids that meet requirements.  
For further information, refer to chapter 16.1 Environmentally Hazardous Auxiliary and Operating Materials.

### **S 15.6 Poisonous exhaust gases**

Exhaust gases can lead to serious or fatal health risks.

- When the engine is running, ensure that there is adequate ventilation such that people are not subjected to exhaust gases for long periods.







### **S 15.7 Complying with technical limit values**

If you do not comply with the technical limit values, the engine can be damaged. This can lead to accidents and serious or fatal injuries.

For further information, refer to chapter [1.3 Technical data and overview](#).

## S 16 Sticker overview

### S 16.1 Warning sticker

Pos.	Description	Symbol	SMO No.	Quantity
1	Warning sticker Hot surface		700897	6
2	Warning sticker Electricity		700898	2
3	Warning sticker Counter rotating rollers		701831	
4	Sticker Fire, open light		703685	1
5	Sticker Common ground		701586	2
6	Sticker Engine lifting point		705204	2

S 16.2 Sticker overview 6 cylinder engine

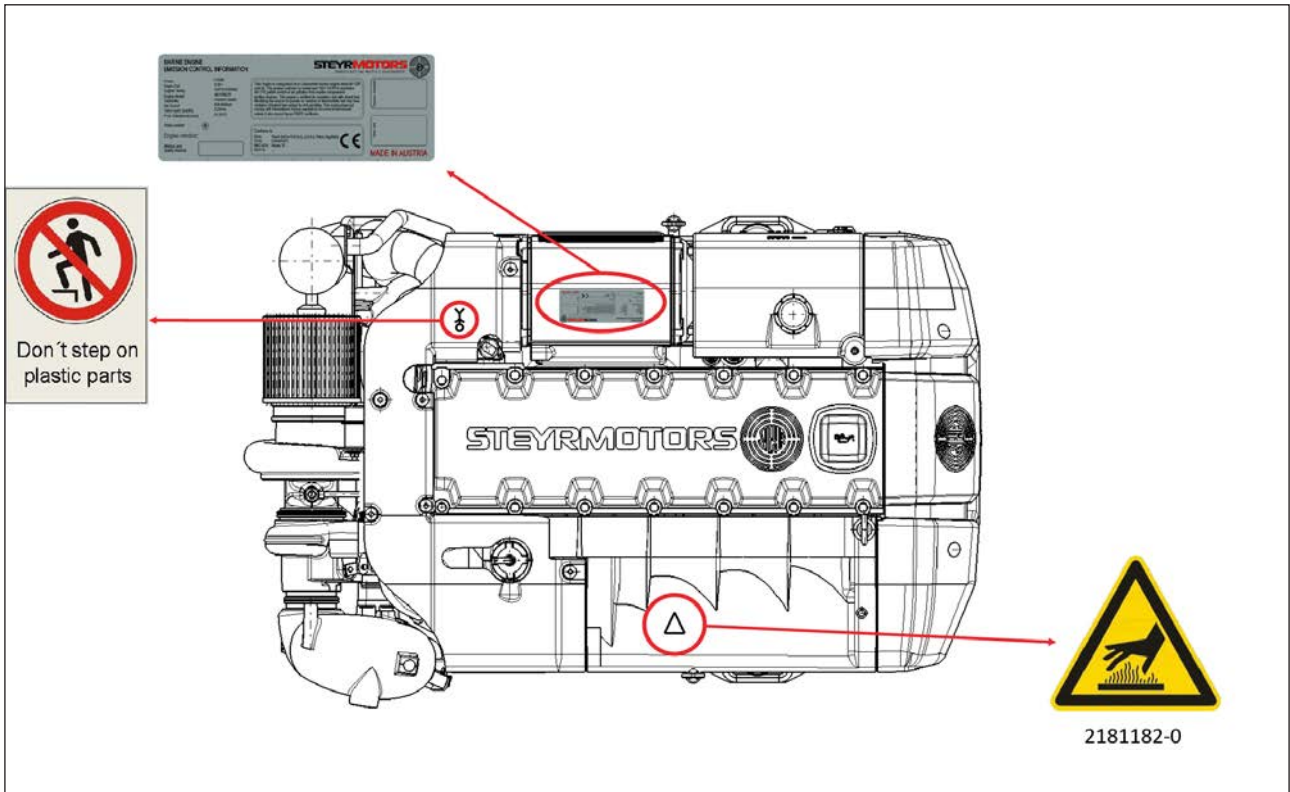

Fig. 1

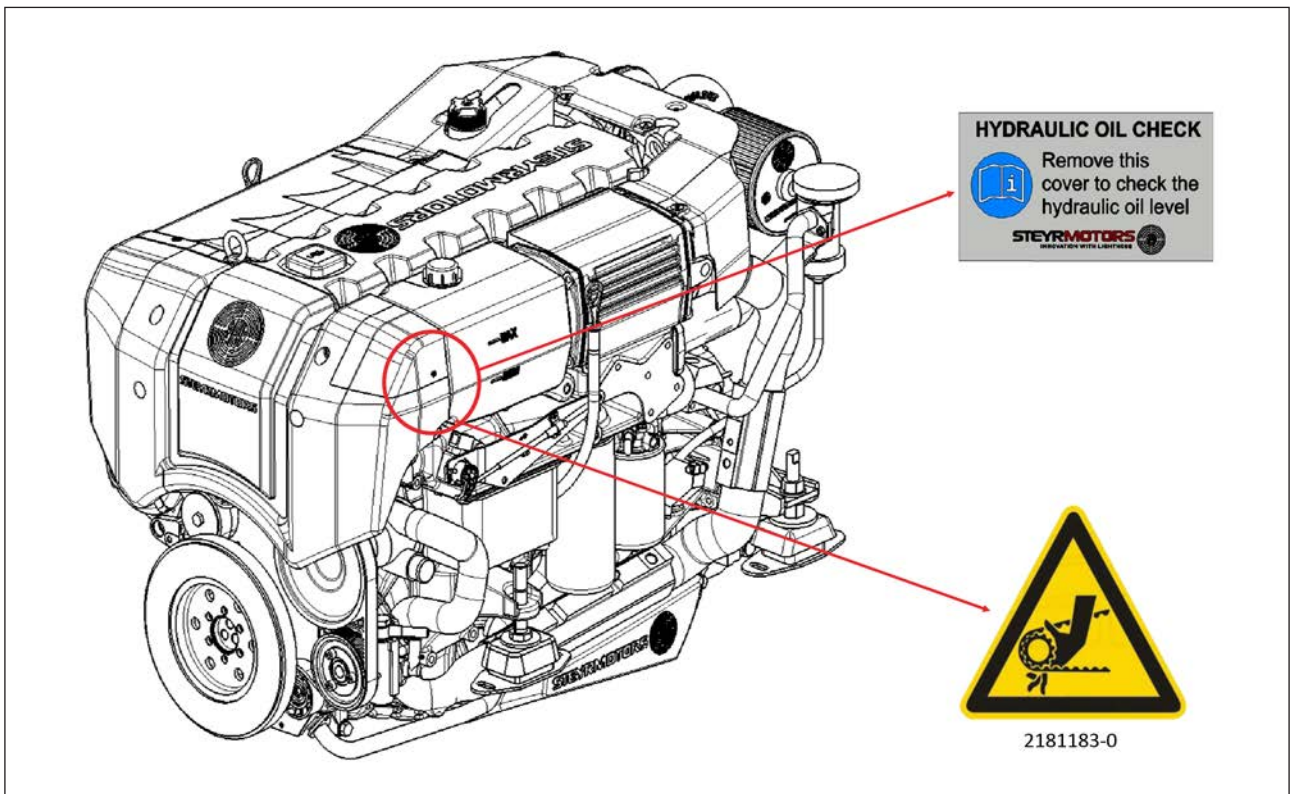

Fig. 2

### S 16.3 Sticker overview 4 cylinder engine

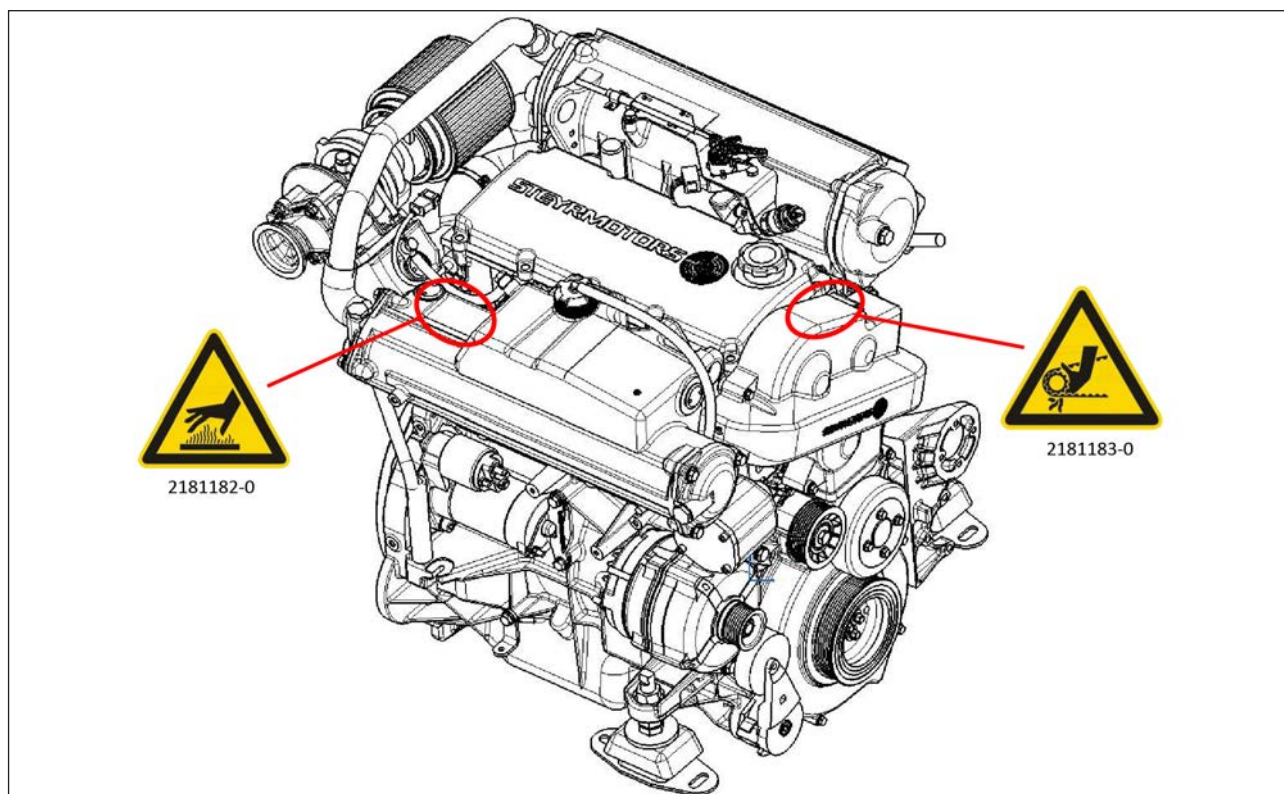

Fig. 3

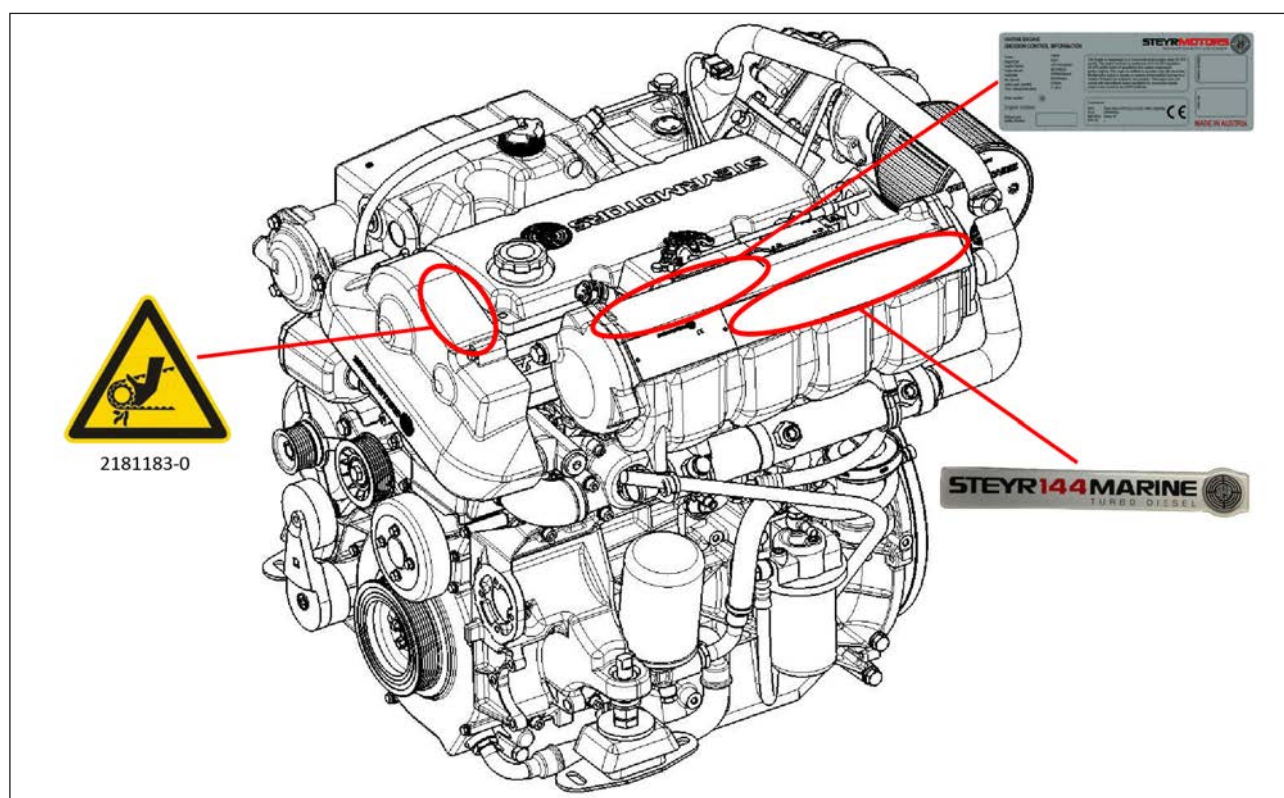

Fig. 4



## 1. General information on installation

### 1.1 Model and serial numbers

The primary model and serial number is located on the engine as illustrated.

**These numbers are required for warranty claims and ordering parts.**

#### 1.1.1 Serial number 6 cylinder engine

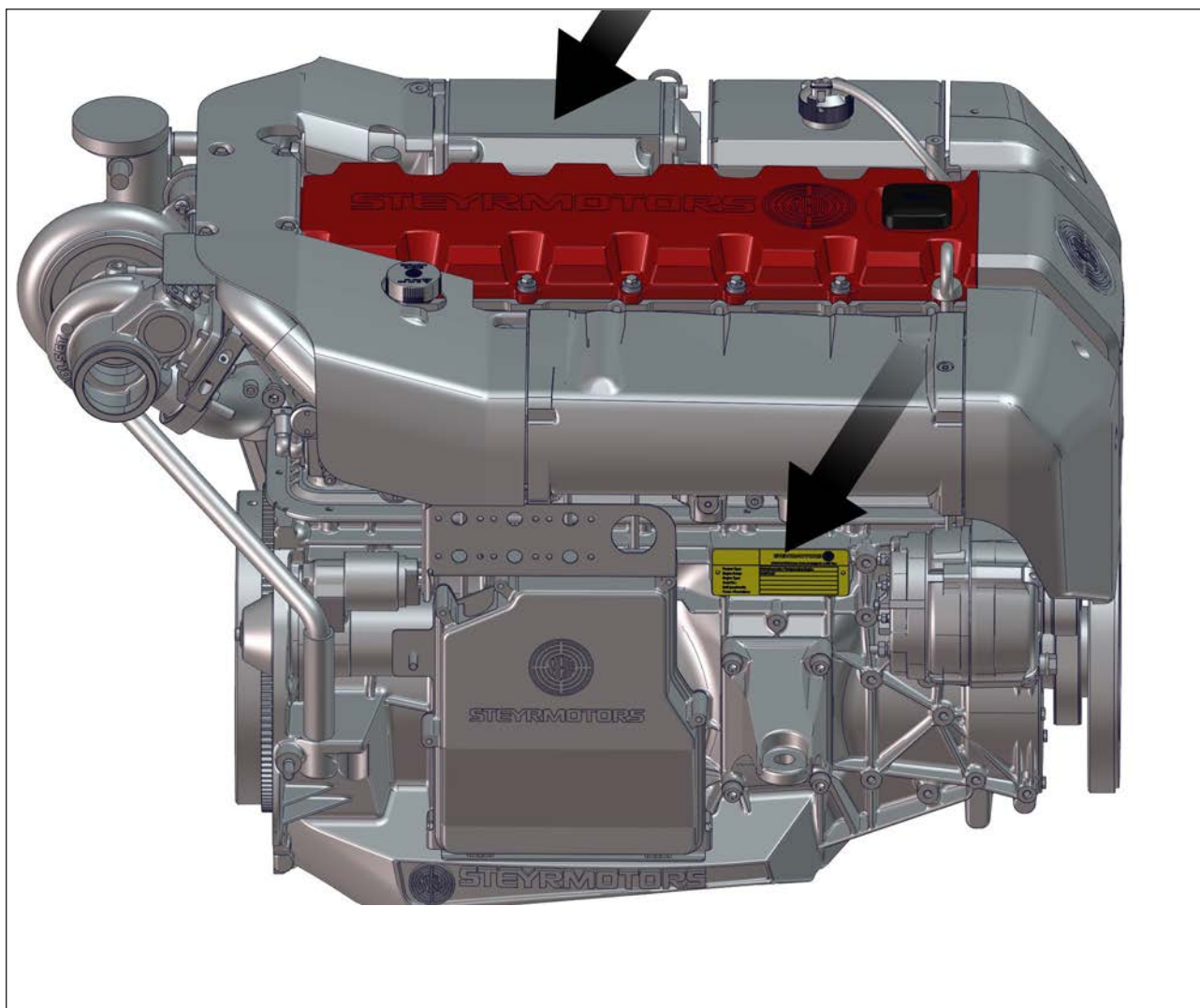

Fig. 5

### 1.1.2 Serial number 4 cylinder engine

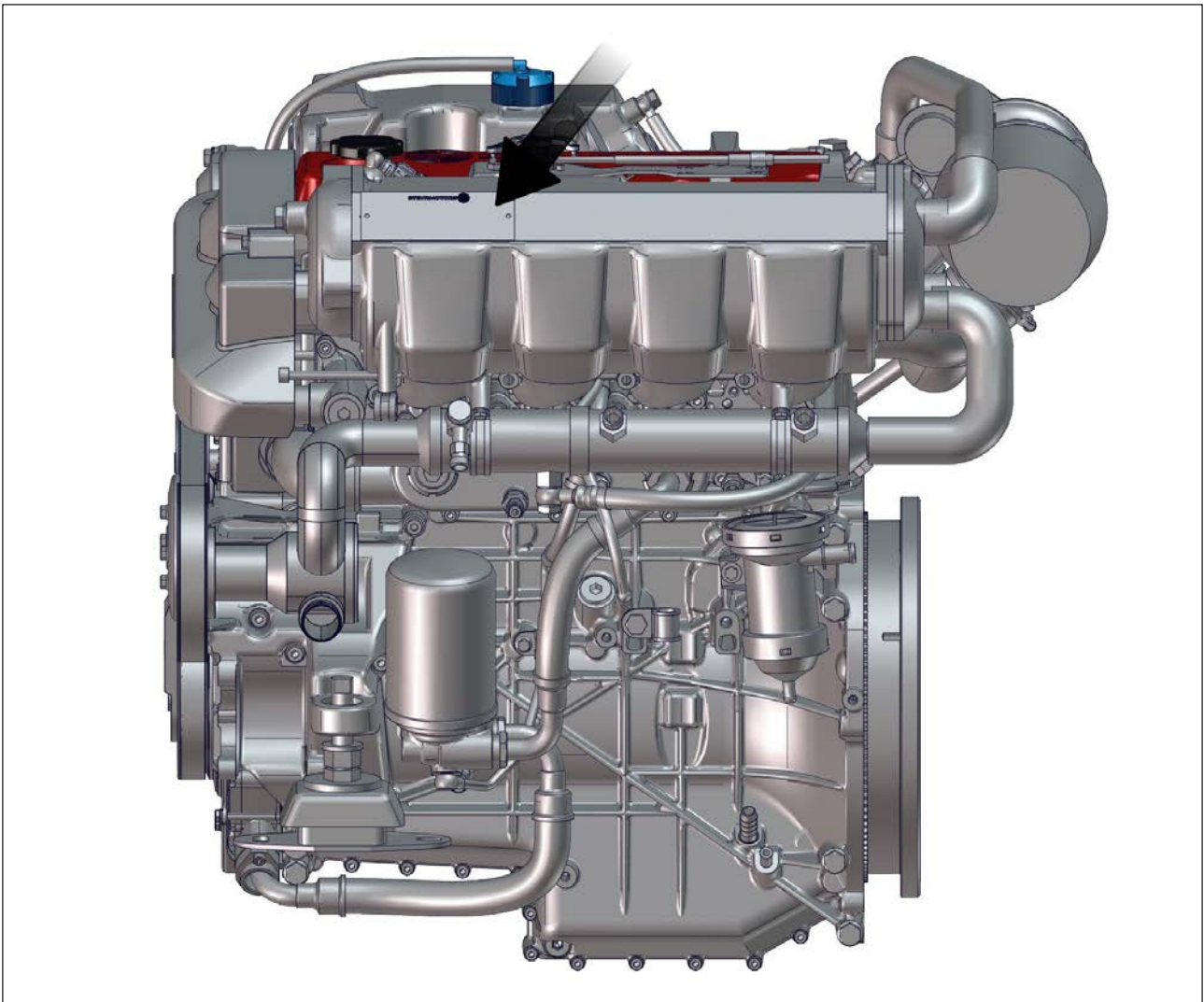

Fig. 6

### 1.1.3 Serial number gear box

The model and serial number of the marine gear-box is located on the marine gearbox housing as illustrated.

---

#### **NOTICE**

To obtain instructions regarding marine gear-box operation, refer to marine gearbox owners manual.

---

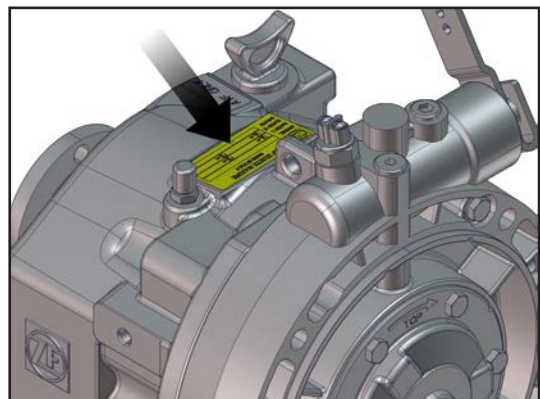

Fig. 7

## 1.2 Documentation

The following documentation is available in English language on our website:

<https://www.steyr-motors.com>

Item		SMO Part number
Installation manual for marine		P/N 707519
Operation, maintenance & warranty manual for marine		P/N 707245
Service manual for marine		P/N 707500
6 cyl.	Spare parts catalogue SE126E32	P/N 707744
	Spare parts catalogue SE156E34	P/N 704591
	Spare parts catalogue SE186E38	P/N 707743
	Spare parts catalogue SE236E40	P/N Z011844-0
	Spare parts catalogue SE236S36	P/N Z011845-0
	Spare parts catalogue SE266E40	P/N Z011846-0
	Spare parts catalogue SE266S36	P/N Z011847-0
	Spare parts catalogue SE286E40	P/N Z011848-0
	Spare parts catalogue SE306J38	P/N Z011840-0
4 cyl.	Spare parts catalogue SE144E38	P/N 500247
	Spare parts catalogue SE164E40	P/N 500167
Optional equipment:	SCC2	P/N 500156
Tool catalogue for Steyr Motors engines		P/N Z001002-1

### Information

Further detailed service information is permanently available for authorized SMO-Service-Partners via log-in to the SMO extranet.

### 1.3 Technical data and overview

#### 1.3.1 Technical data 6 cylinder engine (from year of manufacture 2021)

Item	Unit	Specification		
		SE126E32	SE156E34	SE186E38
Type				
Displacement	cm <sup>3</sup>	3200		
Cylinder bore	mm	85		
Stroke	mm	94		
Rated power	kW	88	113	129
Aspiration		TCA		
Manifold absolute pressure at rated power	mbar	2100	2445	2640
Number of cylinders		6		
Numbering of cylinders		1 <sup>st</sup> at timing belt side		
Firing order		1 - 5 - 3 - 6 - 2 - 4		
Sense of rotation		Clockwise		
Compression ratio		$\epsilon = 17.0$		
Rated speed	rpm	3200	3400	3800
Max. torque	Nm	330	400	420
Max. torque speed	rpm	2050 - 2550	2300 - 2550	2300 - 2800
Idle speed	rpm	630		
Injection		Unit injector system, two-stage, high pressure with electronically controlled injection quantity		
Fuel specification		Diesel according to EN 590		
Fuel cons. at rated power	kg/h	22.2	27.2	31.5
Pre and main fuel filter		Refer to <b>Spare parts catalogue</b>		
Fuel filter location		Pressure sided		
Dry weight	kg	340		
Air filter		Refer to <b>Spare parts catalogue</b>		
Oil filling quantity	lt	17		
Oil filter		Refer to <b>Spare parts catalogue</b>		
Oil specification		SAE 10W-40 ACEA: E6, E7 API: CI-4, CH-4, CG-4, CF-4, CF		
Engine oil and oil filter change intervals		Refer to <b>Service and maintenance schedule</b>		
Cooling system		Dual cooling circuit; thermostat-controlled, pressurized cooling circuit; circulating pump with heat exchanger on engine; external raw water circuit to heat exchange		
Coolant		Steyr Motors engine coolant – 40 °C P/No. 500831, ready mixed		
Coolant water quantity	lt	15.5		
Max. engine cooling raw water outlet temp.	°C	85		
Max. engine coolant outlet temp.	°C	105		
Max. exhaust back pressure	mbar	150		
Back pressure tolerance	mbar	+ 0 / - 50		

### 1.3.2 Technical data 6 cylinder engine

Item	Unit	Specification		
		SE236E40	SE236S36	SE266E40
Type				
Displacement	cm <sup>3</sup>	3200		
Cylinder bore	mm	85		
Stroke	mm	94		
Rated power	kW	170	170	190
Aspiration		TCA		
Manifold absolute pressure at rated power	mbar	2825	2590	2895
Number of cylinders		6		
Numbering of cylinders		1 <sup>st</sup> at timing belt side		
Firing order		1 - 5 - 3 - 6 - 2 - 4		
Sense of rotation		Clockwise		
Compression ratio		$\epsilon = 17.0$		
Rated speed	rpm	4000	3600	4000
Max. torque	Nm	470	540	530
Max. torque speed	rpm	2550-3300	1800-2550	2550-3050
Idle speed	rpm	630		
Injection		Unit injector system, two-stage, high pressure with electronically controlled injection quantity		
Fuel specification		Diesel according to EN 590		
Fuel cons. at rated power	kg/h	42.4	41	47.2
Pre and main fuel filter		Refer to spare part catalogue		
Fuel filter location		Pressure sided		
Dry weight	kg	340		
Air filter		Refer to spare part catalogue		
Oil filling quantity	lt	17		
Oil filter		Refer to spare part catalogue		
Oil specification		SAE 10W-40 ACEA: E6, E7 API: CI-4, CH-4, CG-4, CF-4, CF		
Engine oil and oil filter change intervals		Refer to <b>Service and maintenance schedule</b>		
Cooling system		Dual cooling circuit; thermostat-controlled, pressurized cooling circuit; circulating pump with heat exchanger on engine; external raw water circuit to heat exchange		
Coolant		Steyr Motors engine coolant – 40 °C P/No. 500831, ready mixed		
Coolant water quantity	lt	15.5		
Max. engine cooling raw water outlet temp.	°C	85		
Max. engine coolant outlet temp.	°C	105		
Max. exhaust back pressure	mbar	150		
Back pressure tolerance	mbar	+ 0 / – 50		

## General Information on Installation

Item	Unit	Specification		
		SE266S36	SE286E40	SE306J38
Type				
Displacement	cm <sup>3</sup>	3200		
Cylinder bore	mm	85		
Stroke	mm	94		
Rated power	kW	190	205	215
Aspiration		TCA		
Manifold absolute pressure at rated power	mbar	2810	3080	3175
Number of cylinders		6		
Numbering of cylinders		1 <sup>st</sup> at timing belt side		
Firing order		1 - 5 - 3 - 6 - 2 - 4		
Sense of rotation		Clockwise		
Compression ratio		$\epsilon = 17.0$		
Rated speed	rpm	3600	4000	3800
Max. torque	Nm	600	570	588
Max. torque speed	rpm	1800-2300	2550-3300	3300
Idle speed	rpm	630		
Injection		Unit injector system, two-stage, high pressure with electronically controlled injection quantity		
Fuel specification		Diesel according to EN 590		
Fuel cons. at rated power	kg/h	46.1	50.3	51.9
Pre and main fuel filter		Refer to spare part catalogue		
Fuel filter location		Pressure sided		
Dry weight	kg	340		
Air filter		Refer to spare part catalogue		
Oil filling quantity	lt	17		
Oil filter		Refer to spare part catalogue		
Oil specification		SAE 10W-40 ACEA: E6, E7 API: CI-4, CH-4, CG-4, CF-4, CF		
Engine oil and oil filter change intervals		Refer to <b>Service and maintenance schedule</b>		
Cooling system		Dual cooling circuit; thermostat-controlled, pressurized cooling circuit; circulating pump with heat exchanger on engine; external raw water circuit to heat exchange		
Coolant		Steyr Motors engine coolant – 40 °C P/No. 500831, ready mixed		
Coolant water quantity	lt	15.5		
Max. engine cooling raw water outlet temp.	°C	85		
Max. engine coolant outlet temp.	°C	105		
Max. exhaust back pressure	mbar	150		
Back pressure tolerance	mbar	+ 0 / – 50		

### 1.3.3 Overview 6 cylinder engine

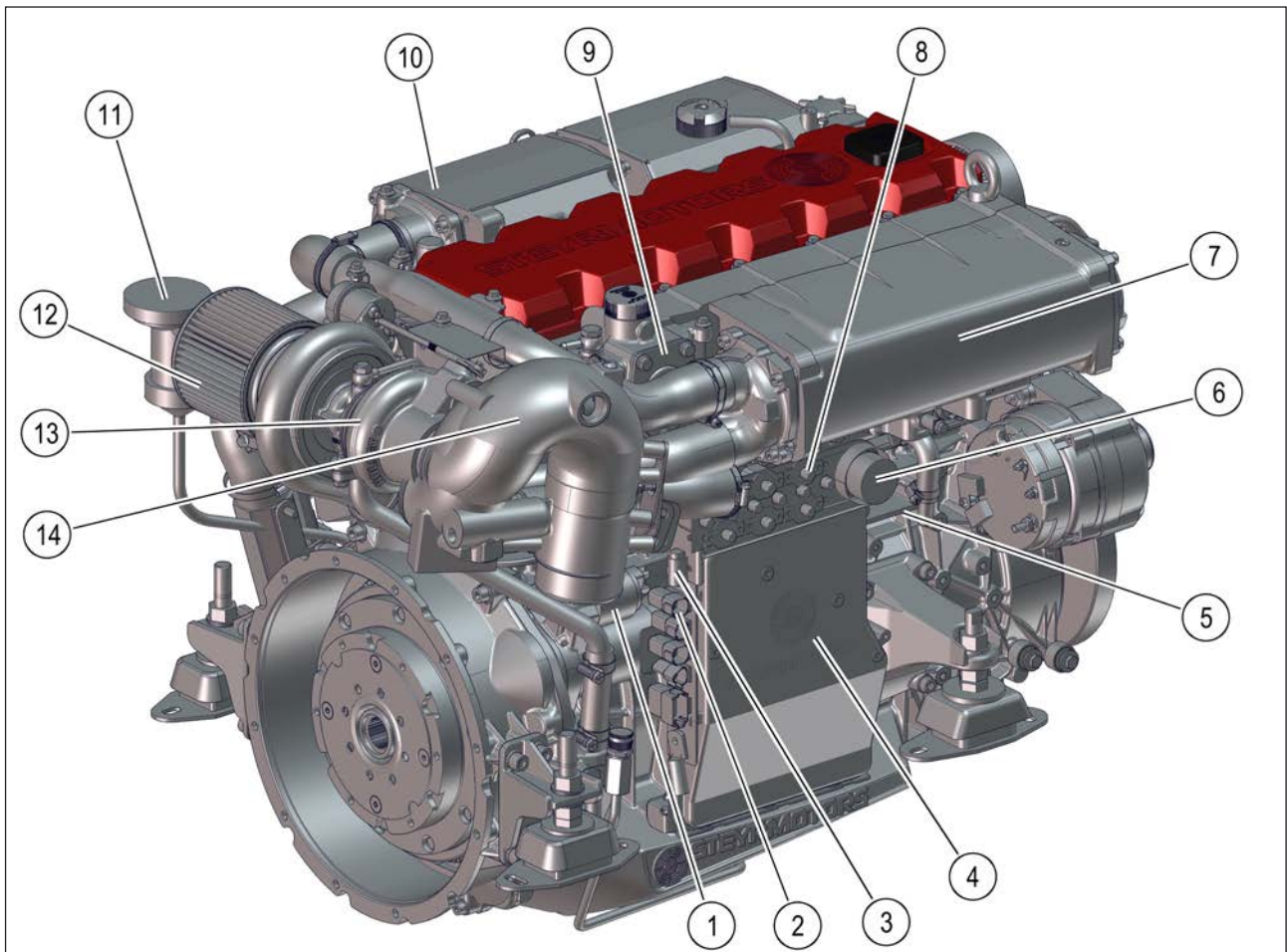

Fig. 8

Pos.	Description	Pos.	Description
1	Starter motor	8	Fuses (Circuit breakers)
2	Diagnostic outlet	9	Thermostat housing
3	Inversion switch	10	Inter cooler
4	Engine control unit (ECU) / relais	11	Oil separator
5	Model and serial number	12	Air filter
6	Connector instrument panel	13	Turbo charger
7	Heat exchanger	14	Exhaust elbow

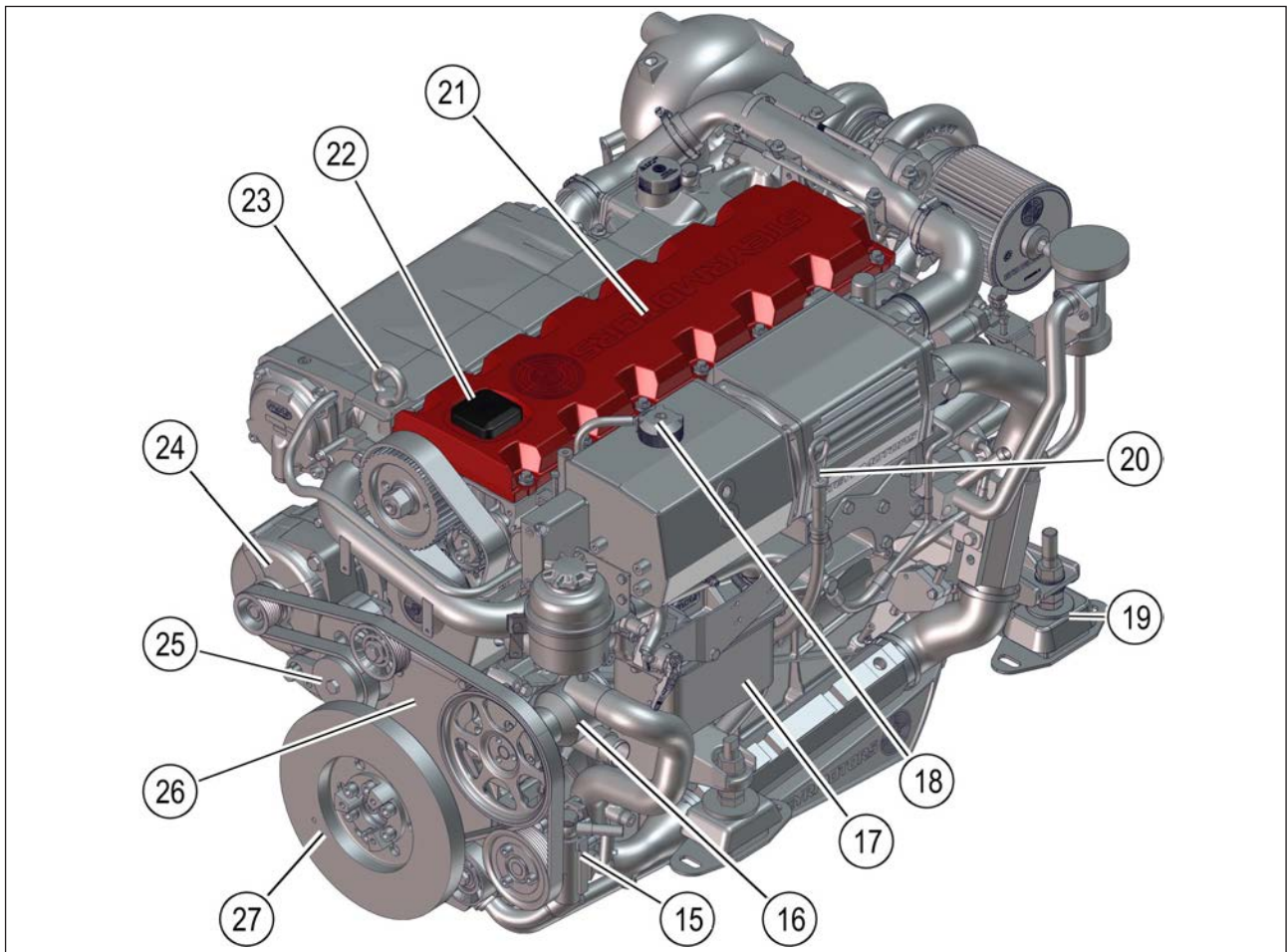

Fig. 9

Pos.	Description
15	Hydraulic pump
16	Raw water pump
17	Oil cooler
18	Cooler cap
19	Engine mount
20	Oil dipstick
21	Camshaft housing cover

Pos.	Description
22	Engine oil filler cap
23	Engine lifting eye
24	Alternator
25	Poly-v belt tensioner
26	Cover timing belt
27	Vibration damper

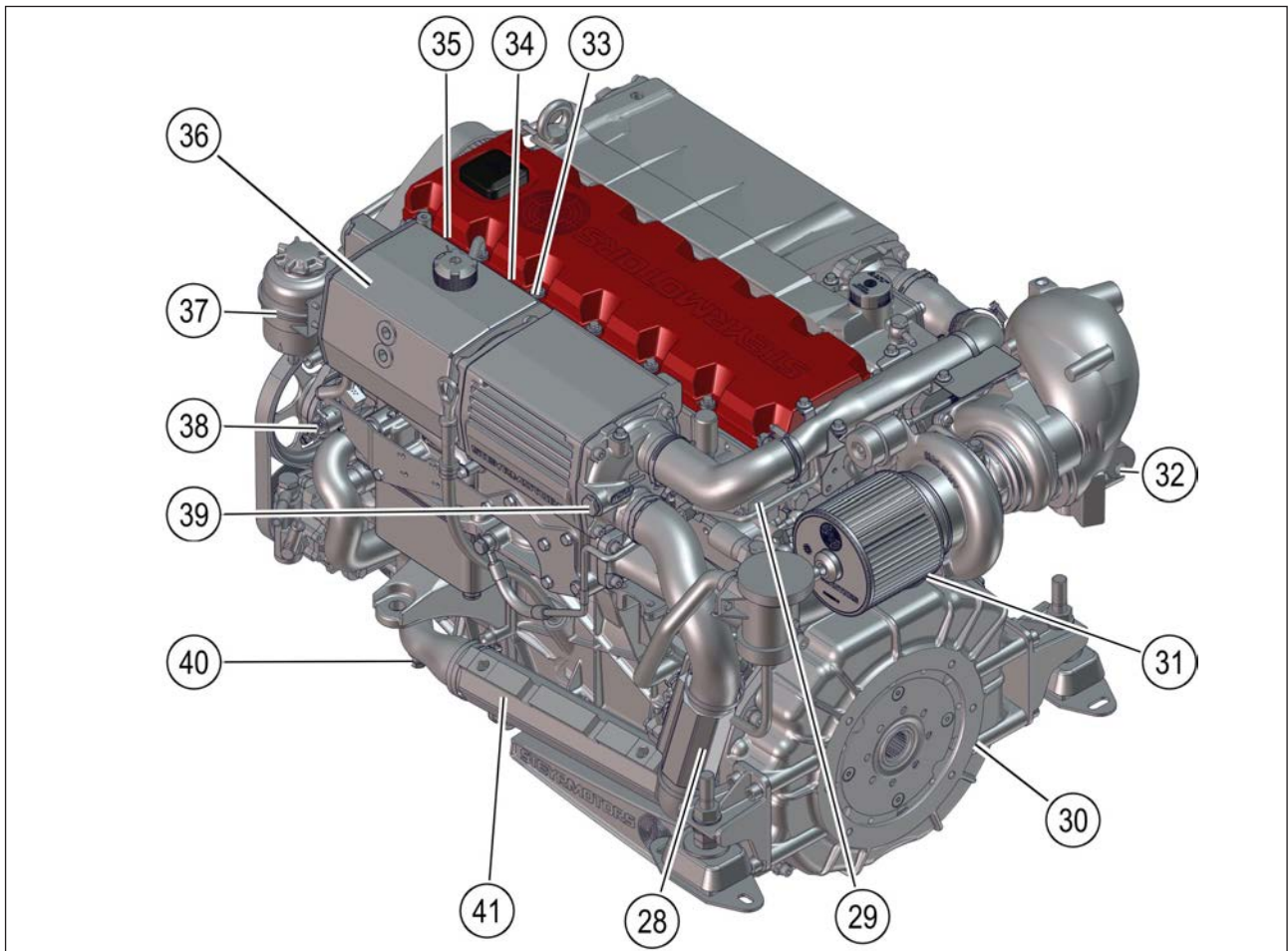

Fig. 10

Pos.	Description
28	Fuel cooler
29	Injection timing position sensor
30	Flywheel housing
31	Oil pressure sensor
32	Zinc anode
33	Charge air temperature sensor
34	Manifold absolute pressure sensor
36	Rack position sensor

Pos.	Description
35	Rack position sensor
36	Coolant expansion tank
37	Hydraulic oil tank
38	Potentiometer accelerator
39	Zinc anode
40	Raw water drain plug
41	Hydraulic oil cooler

### 1.3.4 Dimensions 6 cylinder engine

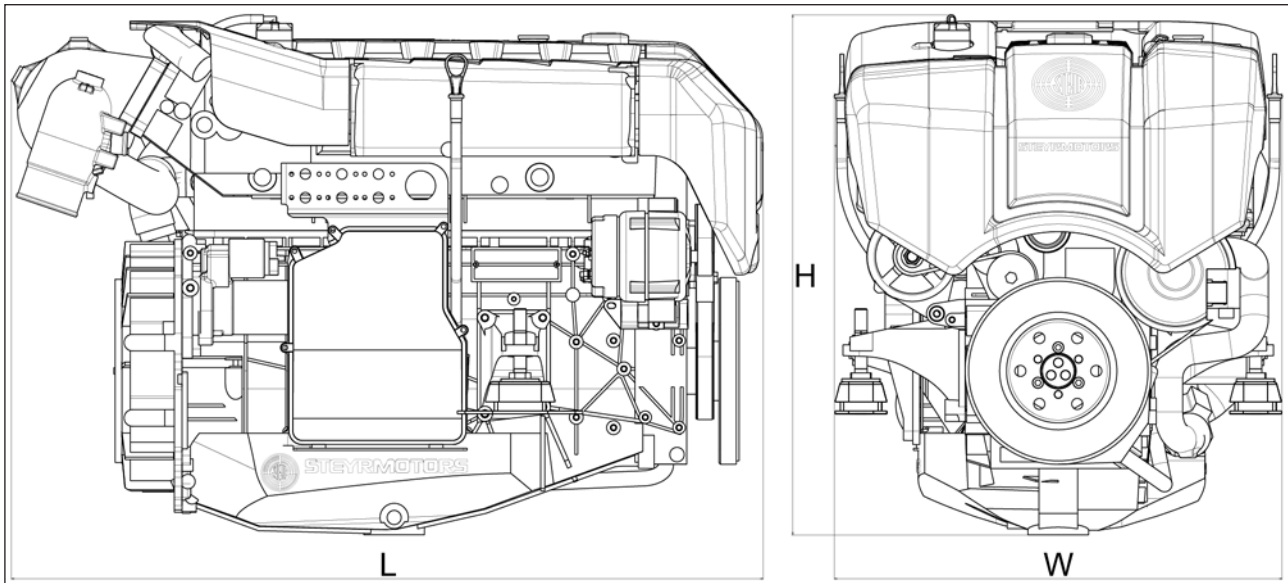

Fig. 11

Item	Description	Metric system [mm]	Imperial unit [inch]
L	Length	1090	42.9
H	Height	752	29.6
W	Width	649	25.6

#### **i** Information

The figure shows the main dimensions of the engine assembly. Surrounding parts (e.g. oil filter, wiring harness, etc.) are not considered.

1.3.5 Technical data 4 cylinder engine (from year of manufacture 2021)

Item	Unit	Specification	
		SE144E38	SE164E40
Type			
Displacement	cm <sup>3</sup>	2133	
Cylinder bore	mm	85	
Stroke	mm	94	
Rated power	kW	106	118
Aspiration		TCA	
Manifold absolute pressure at rated power	mbar	2575	2815
Number of cylinders		4	
Numbering of cylinders		1 <sup>st</sup> at timing belt side	
Firing order		1 - 3 - 4 - 2	
Sense of rotation		Clockwise	
Compression ratio		$\epsilon = 17.0$	
Rated speed	rpm	3800	4000
Max. torque	Nm	320	330
Max. torque speed	rpm	2300	2300
Idle speed	rpm	750	
Injection		Unit injector system, two-stage, high pressure with electronically controlled injection quantity	
Fuel specification		Diesel according to EN 590	
Fuel cons. at rated power	kg/h	27.1	29.5
Pre and main fuel filter		Refer to spare part catalogue	
Fuel filter location		Suction sided	
Dry weight	kg	263	
Air filter		Refer to spare part catalogue	
Oil filling quantity	lt	8.75	
Oil filter		Refer to spare part catalogue	
Oil specification		SAE 10W-40 ACEA: E6, E7 API: CI-4, CH-4, CG-4, CF-4, CF	
Engine oil and oil filter change intervals		Refer to <b>Service and maintenance schedule</b>	
Cooling system		Dual cooling circuit; thermostat-controlled, pressurized cooling circuit; circulating pump with heat exchanger on engine; external raw water circuit to heat exchange	
Coolant		Steyr Motors engine coolant – 40 °C P/No. 500831, ready mixed	
Coolant water quantity	lt	10.7	
Max. engine cooling raw water outlet temp.	°C	85	
Max. engine coolant outlet temp.	°C	105	
Max. exhaust back pressure	mbar	150	
Back pressure tolerance	mbar	+ 0 / – 50	

1.3.6 Overview 4 cylinder engine

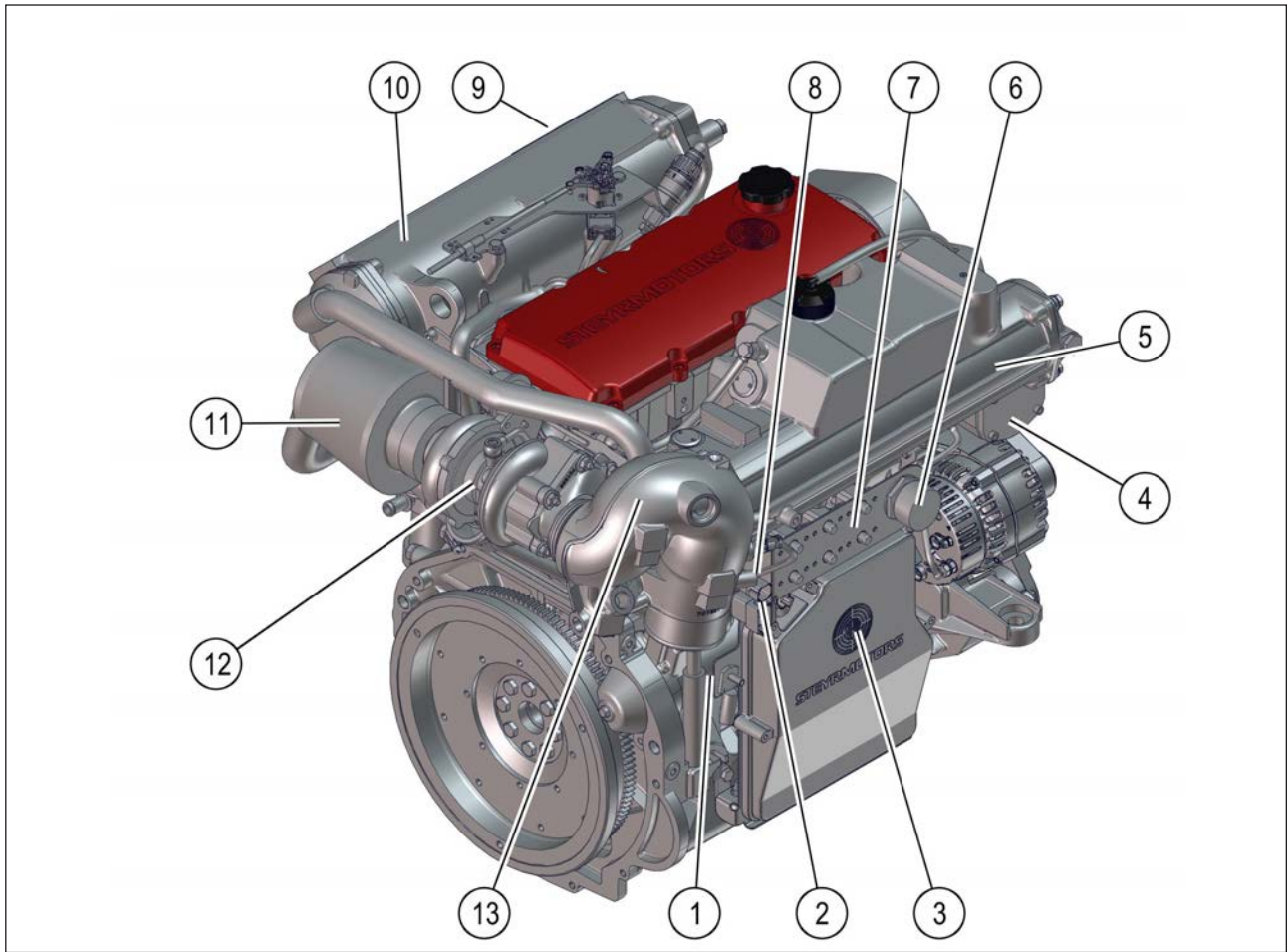

Fig. 12

Pos.	Description	Pos.	Description
1	Starter motor	8	Inversion switch
2	Diagnostic outlet	9	Model and serial number
3	Engine control unit (ECU) / relais	10	Intercooler
4	Thermostat housing	11	Air filter
5	Heat exchanger	12	Turbo charger
6	Connector instrument panel	13	Exhaust elbow
7	Fuses (Circuit breakers)		

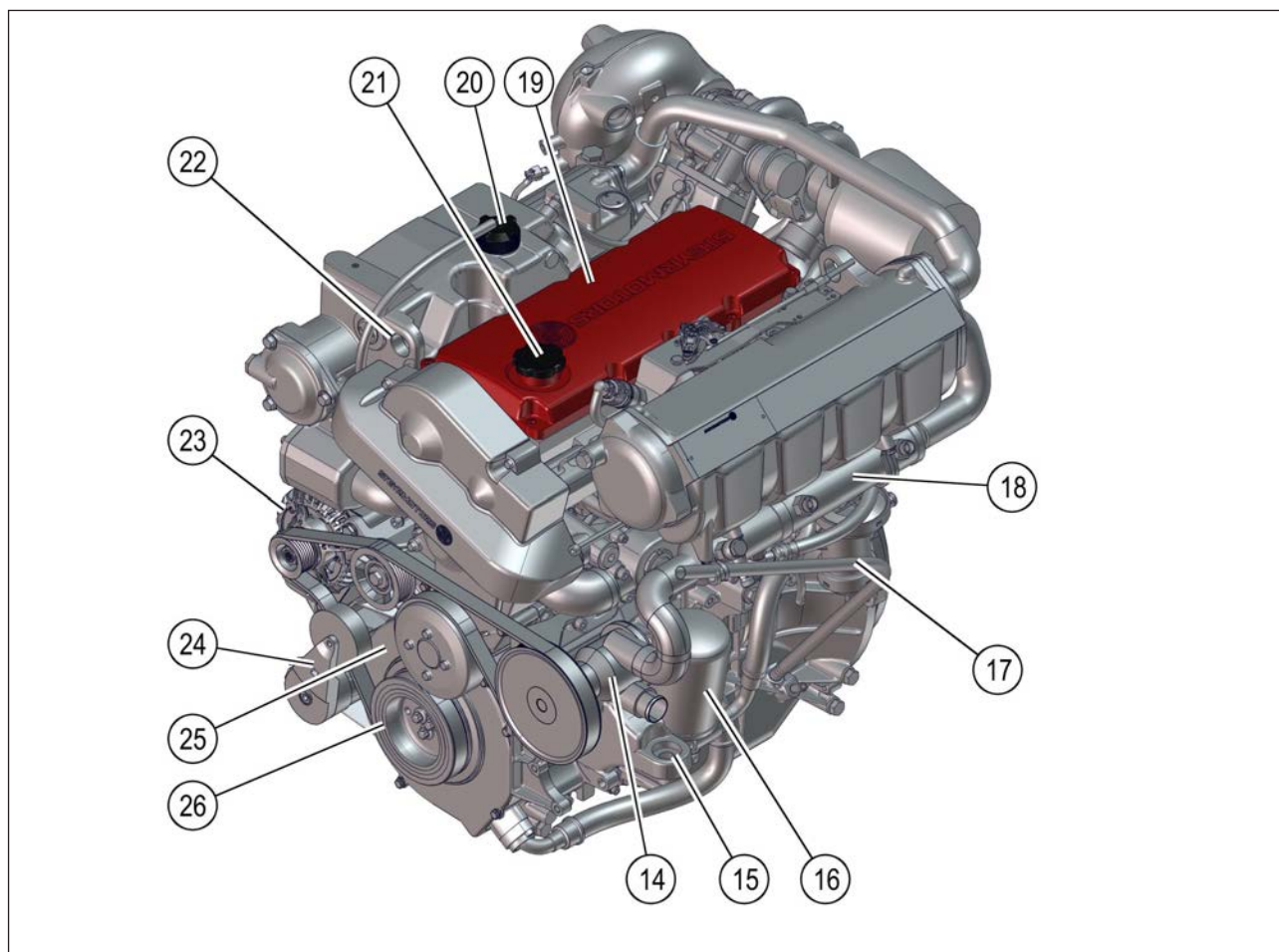

Fig. 13

Pos.	Description
14	Raw water pump
15	Engine mount
16	Oil filter
17	Oil dipstick
18	Tandem cooler, fuel - hydraulic oil
19	Camshaft housing cover
20	Cooler cap

Pos.	Description
21	Engine oil filler cap
22	Engine lifting eye
23	Alternator
24	Poly-v belt tensioner
25	Cover timing belt
26	Vibration damper

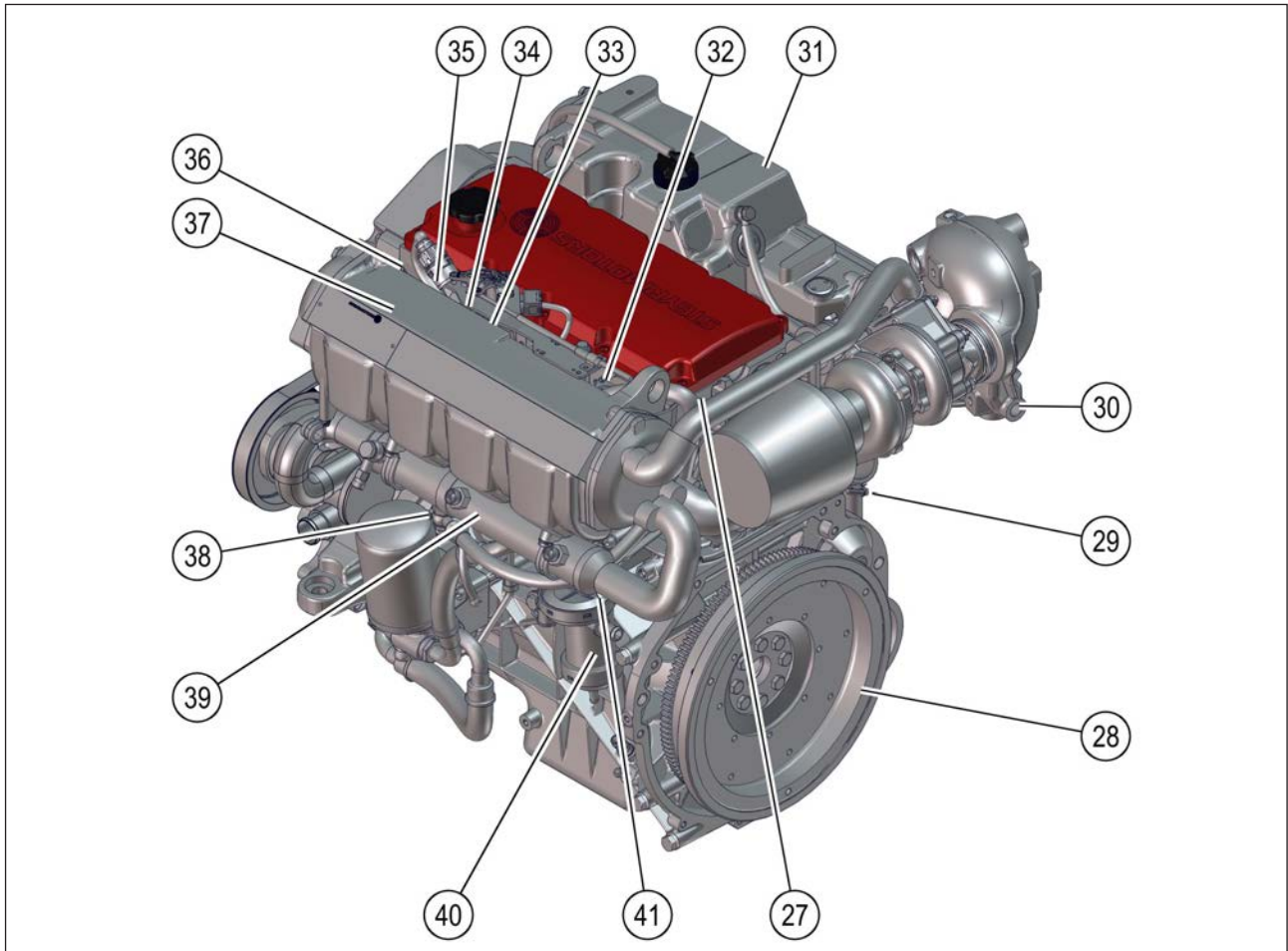

Fig. 14

Pos.	Description
27	Injection timing position sensor
28	Flywheel
29	Oil pressure sensor
30	Zinc anode
31	Coolant expansion tank
32	Injection timing device
33	Charge air temperature sensor
34	Potentiometer accelerator

Pos.	Description
35	Manifold absolute pressure sensor
36	Rack position sensor
37	Intercooler
38	Engine coolant drain plug
39	Tandem cooler, fuel - hydraulic oil
40	Oil separator
41	Raw water drain plug

1.3.7 Dimensions 4 cylinder engine

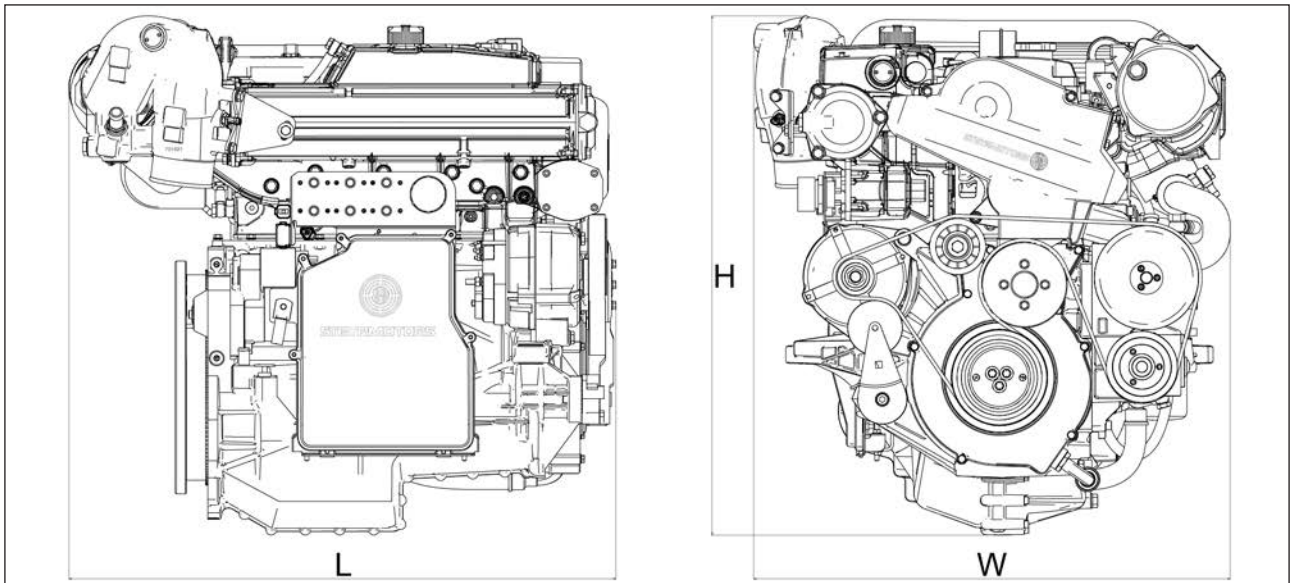

Fig. 15

Item	Description	Metric system [mm]	Imperial unit [inch]
L	Length	798	31.42
H	Height	757	29.80
W	Width	703	27.68

**i** Information

The figure shows the main dimensions of the engine assembly. Surrounding parts (e.g. oil filter, wiring harness, etc.) are not considered.

1.3.8 Sensors and actuators overview

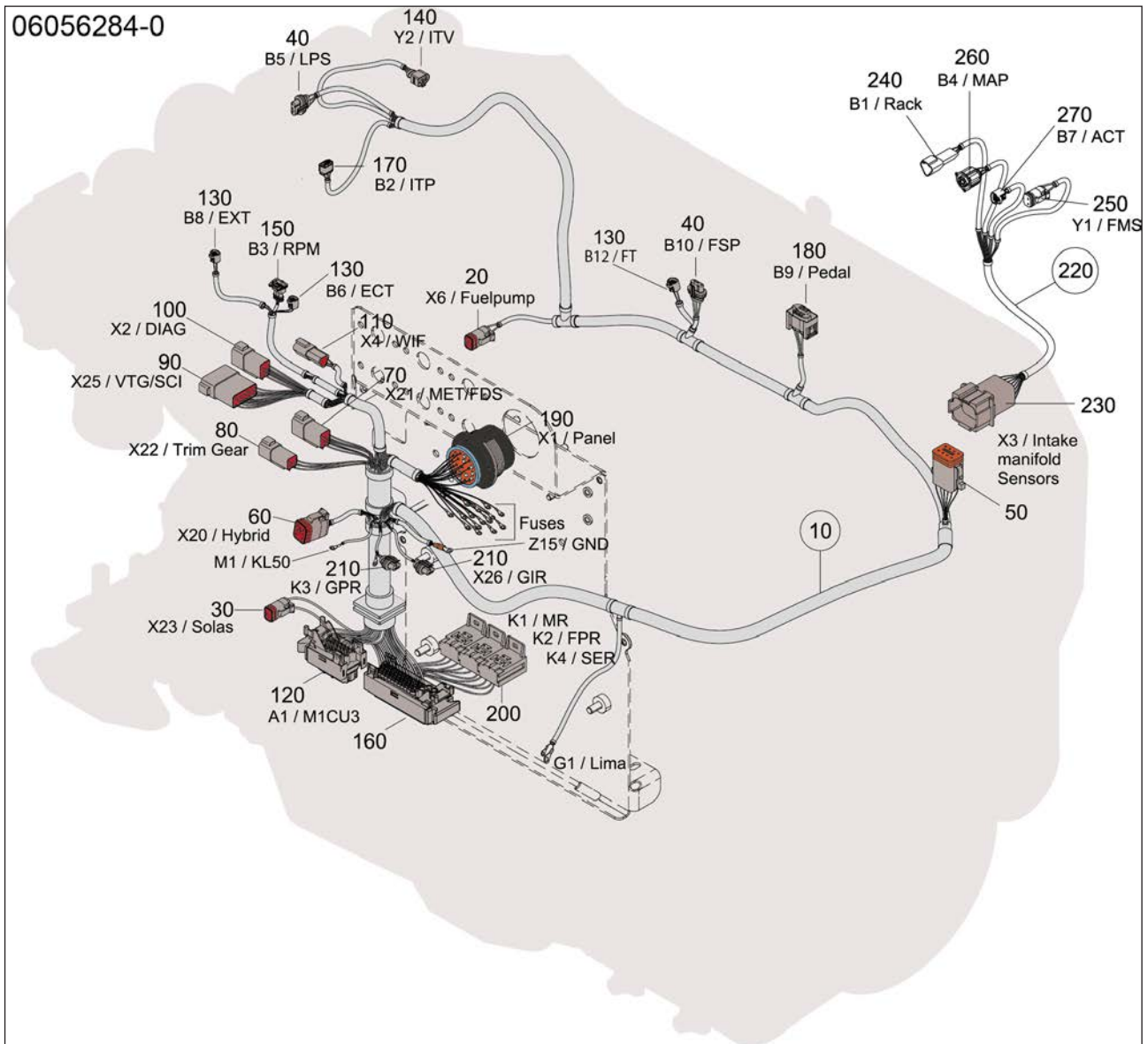

Fig. 16

Conn.	Item
A1	M1CU3
B1	Rack
B2	ITP
B3	RPM
B4	MAP
B5	LPS
B6	ECT
B7	ACT
B8	EXT
B9	Pedal
B10	FSP
B12	FT (as of 2021)

Conn.	Item
G1	Lima
K1	MR
K2	FPR
K3	GPR
K4	SER
M1	KL50
X1	Panel
X2	DIAG
X3	Intake manifold
X4	WIF
X6	Fuel supply pump

Conn.	Item
X20	Hybrid
X21	MET/FDS
X22	Trim gear
X23	Solas
X25	VTG/SCI
X26	GIR
Y1	FMS
Y2	ITV
Z15	GND

## 2. Weight-distribution balance

It is important that the heavy components, such as fuel tanks, water tanks and batteries are installed in such a way that the best possible planing position of the boat will be kept. Of course the optimum gliding position differs from boat to boat but the best possible weight-distribution balance should always be the aim.

---

### **WARNING**

#### **Risk of injury due to explosion and fire!**

On account of the risk of explosion and fire the fuel tanks, batteries and engines are to be placed in well ventilated compartments separated from each other. More details will follow.

---

### 2.1 Accessibility

During assembly of the engine, take great care as to accessibility for service works. An easy exchange of pump wheels, oil filters, air filters, water filters, fuel filters, v-belts etc. must be guaranteed.

---

### **NOTICE**

#### **Possible gearbox damage by changing gear at higher engine speed.**

- ▶ There should also be adequate space for sound-absorbing material. Dimensional drawings of the relevant engine may be found in the following contents.
- 

Overview

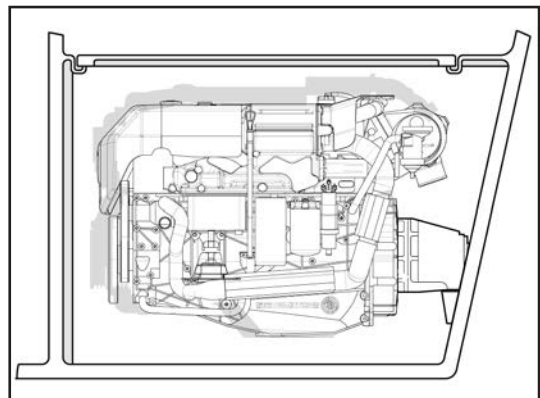

Fig. 17

### Overview

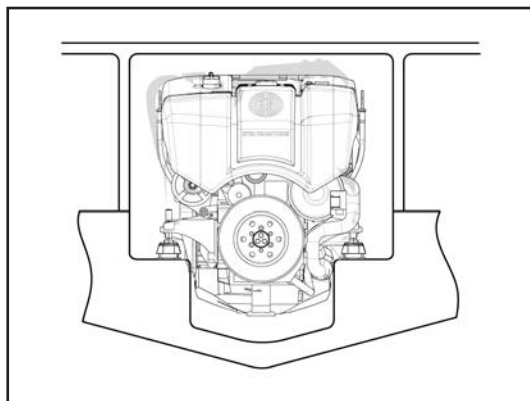

Fig. 18

## 2.2 Displacement of water

In order to determine the displacement of water of a boat, the weight of the boat should if possible be measured. If this is not possible and if there is also no model of the hull from the boat-builder, a computation is to be made.

Before beginning computation, the position of the water line should be checked on different points of the hull with normal boat loading, since every change in weight has a strong effect on the speed of the boat.

At first, subdivide the hull into different sectors. Overlapping of the individual sectors with the actual waterline will result in different fields with different volumes, and by adding these volumes the displacement of water can be calculated. For the accuracy of calculation the number of subdivisions is determining (e.g. Simpson's First Rule, Murphy's Law ...).

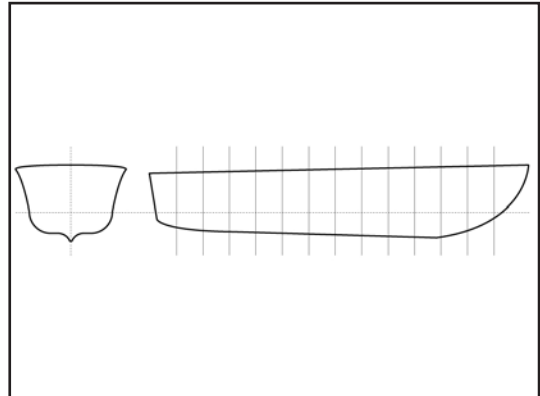

Fig. 19

The displacement of water can also be determined by the **block coefficient** which, however, is more inaccurate. In this case, the difference between the volume of the keel and that of a body which intersects the outer edges of the boat is determined. But in practice it is very difficult to compute the volume of the keel.

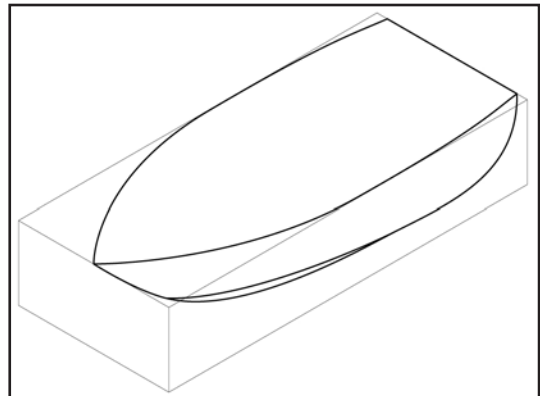

Fig. 20

### 2.2.1 Examples for block coefficient

By means of the “**Block coefficient**” the displacement of water can be estimated for every type of boat. The value in figure below refers to a section of the hull at the widest spot.

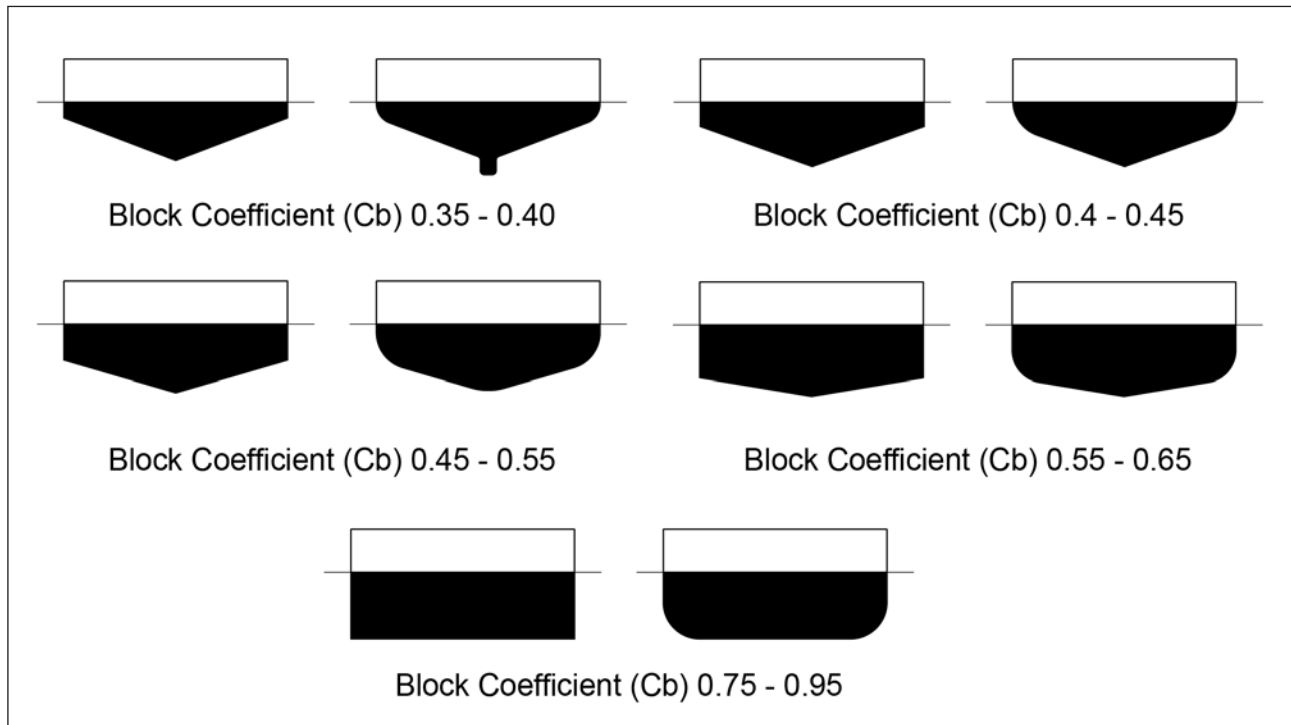

Fig. 21

### 2.3 List of operating materials

Mounted parts from a third party, which are not in the standard scope of delivery from **Steyr Motors**, have to be designed properly in dimensions and protected accordingly in order to prevent accidents.

Further maintenance and inspection through authorized technicians should be secured.

An entire list of the operating material is available in the spare parts catalogue.

### 2.4 Disposal of operating materials

Used operating material is to be collected in special containers to enable possible subsequent treatment.



## Environment

All operating materials for the engine are subject to the Special Waste Act for disposal. The "Special Waste Catalogue" ÖNORM S 2100 refers to the required disposal in Austria.

Respective legal local regulations are to be followed.

The maintenance and repair personnel have to take care that operating material and other material to be regarded as special waste product, is always deposited at a collection site.

Key no.	Description
31 423	Oil contaminated soil or oil bonding agent
54 102	Waste oil
54 104	Fuels
54 202	Lubricants
54 207	Vaseline
54 917	Solid sealing material
54 927	Oil soiled cleaning rags
54 928	Used oil and air filters
55 510	Paint and varnish containing waste material



## Environment

**Waste oil can endanger the environment.**

- ▶ Dispose waste oil according to the local rules and regulations.
- ▶ Dispose oily rags or contaminated cleaning utensils properly, to avoid fire.



## Environment

**A leakage of operation materials during operation can contaminate soil and water.**

- ▶ Avoid leaks.
- ▶ Check regularly seal tightness and proper functioning.
- ▶ Take immediate action if environmentally hazardous materials reach the environment.
- ▶ If necessary, inform the responsible local authorities about damages.

## 2.5 SI - system

## General Information on Installation

---

The following measuring units are used:

<b>Linear</b>	<b>Pressure and stress</b>
km = kilometre	bar = bar
m = metre	Pa = pascal
mm = millimetre	kPa = kilopascal
" = inch	N/mm <sup>2</sup> = newton per square millimetre

<b>Area</b>	<b>Energy</b>
m <sup>2</sup> = square metre	J = joule
cm <sup>2</sup> = square centimetre	kWh = kilowatt hour

<b>Volume</b>	<b>Power</b>
m <sup>3</sup> = cubic metre	kW = kilowatt
cm <sup>3</sup> = cubic centimetre	
dm <sup>3</sup> = cubic decimetre	
mm <sup>3</sup> = cubic millimetre	
l = litre	
ml = millilitre	

<b>Mass</b>	<b>Temperature</b>
t = metric ton	K = degree Kelvin
kg = kilogram	°C = degree Celsius
g = gram	

<b>Force</b>	<b>Time</b>
N = newton	h = hour
kN = kilo newton	min = minute
daN = deka newton	s = second

<b>Electricity</b>	<b>Velocity</b>
A = ampere	km/h = kilometre per hour
V = volt	m/s = metre per second
Ω = ohm	
μF = micro farad	

<b>Fuel consumption</b>	<b>Speed</b>
g/kWh = gram per kilowatt hour	1/min = r.p.m.

2.5.1 Conversion table SI - US









Volume		Power / Energy	
1 cm <sup>3</sup>	= 0.061 in <sup>3</sup>	1 kN	= 224.81 lbf
1 m <sup>3</sup>	= 35.31 ft <sup>3</sup>	1 kW	= 1.36 PS/hp
1 ml	= 0.034 US fl.oz.	1 PS/hp	= 0.74 kW
1 l	= 0.26 US gal	Torque	
1 l/min	= 0.26 US gal/min	1 Nm	= 0.74 ft.lbs.
Length		Velocity	
1 mm	= 0.039 in	1 km/h	= 0.62 mph
1 m	= 3.28 ft		
Mass		Acceleration	
1 kg	= 2.2 lbs	1 m/s <sup>2</sup>	= 3.28 ft/s <sup>2</sup>
1 g	= 0.035 oz		
Pressure		Area	
1 bar	= 14.5 psi	1 m <sup>2</sup>	= 10.76 ft <sup>2</sup>
1 kg/cm <sup>2</sup>	= 14.22 lbs/in <sup>2</sup>	1 cm <sup>2</sup>	= 0.155 in <sup>2</sup>













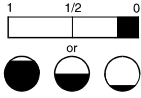







### 2.6 Abbreviations

APS	<b>A</b> bsolute <b>P</b> ressure <b>S</b> ensor (Barometric)
BDC	<b>B</b> ottom <b>D</b> ead <b>C</b> entre
BMK	Resources to be labelled
CEL	<b>C</b> heck <b>E</b> ngine <b>L</b> amp
Cu	Copper
ECT	<b>E</b> ngine <b>C</b> oolant <b>T</b> emperature
ECU	<b>E</b> lectronic <b>C</b> ontrol <b>U</b> nit
EMS	<b>E</b> lectronic <b>M</b> anagement <b>S</b> ystem
Fig.	Figure
HGrp	Master unit
ill.	Illustration
ITD	<b>I</b> njection <b>T</b> iming <b>D</b> evice
MAssy	<b>M</b> ain <b>A</b> ssembly
max.	Maximum
min.	Minimum
MSV	Machine safety regulation (ger.: <b>M</b> aschinen <b>S</b> icherheits <b>v</b> erordnung)
Nm	Newton meter
OT	Top Dead Center
PTO	( <b>P</b> ower <b>T</b> ake <b>O</b> ff) power transmission at front crankshaft end
SMO	<b>S</b> teyr <b>M</b> otors <b>A</b> G
TDC	<b>T</b> op <b>D</b> ead <b>C</b> entre
wc	Water column
WS	<b>W</b> rench <b>S</b> ize (Head width)

### 2.7 Notes on safety

Certain symbols or combinations of symbols may appear on your **Steyr Motors** marine engine or on its accessories. It is very important that you understand their meaning or purpose. If any symbol is not clearly understood, see your dealer.

<b>"Safety Warning" Symbols</b>			
	Means risk of <b>SERIOUS</b> injury is present. Follow instructions in the Operation, Maintenance & Warranty Manual before using engine or accessory.		Means place shift control in <b>NEUTRAL</b> before starting motor. Follow instructions in Operation, Maintenance & Warranty Manual before starting engine.
			Indicates that <b>ELECTRICITY</b> of more than 50 volts is present.
	Indicates that contents are under pressure.		Identifies poisonous material.
<b>"Position Indicator" Symbols</b>			
	Indicates upward movement. Example: While boat is at planing speed, activating trim switch to raise the bow of the boat.		Indicates downward movement. Example: While boat is at planing speed, activating trim switch to lower the bow of the boat.
			Indicates gear shift control positions: <b>FORWARD</b> , <b>NEUTRAL</b> and <b>REVERSE</b>

<b>"Condition" Symbols</b>			
	Identifies the meter which indicates accumulative running hours of engine.		Identifies the meter which indicates battery voltage or amperage.
	Identifies battery or a meter which indicates status of battery-generator charging system.		Indicates the amount of liquid in tank.
	Identifies the meter which indicates engine coolant temperature.		<b>FILTER:</b> Identifies a device which removes contaminants from engine's oil system.
			Identifies the meter which indicates engine speed expressed in revolutions per minute.
			Identifies the meter which indicates engine coolant pressure.
			Identifies the meter which indicates the pressure of engine's lubricating system.
<b>"Functional Description" Symbols</b>			
	<b>FILTER:</b> Identifies a device which removes contaminants from fuel.		Identifies the <b>EMERGENCY IGNITION CUT-OFF SWITCH</b> . Emergency engine stop.
	Identifies the negative ground or negative voltage connection.		Identifies engine drain plugs and fittings.
			Identifies the operating device for starting the engine.
	Identifies the <b>STOP SWITCH</b> . It may also identify <b>STOP</b> position of the throttle control.		
<b>"Instructional" Symbols</b>			
	Indicates <b>FUEL</b> is to be used or <b>FUEL</b> is present.		Means read your Operation, Maintenance & Warranty Manual before operating the product. It contains information or instructions vital for operation of product.
	Indicates <b>OIL</b> is to be used or <b>OIL</b> is present.		<b>ENGINE OIL FILL:</b> Location for introduction of oil into the engine.
			Indicates areas to be lubricated.
			Indicates lubricating oil used in transmissions.

### 2.7.1 General notes on safety

The general knowledge and training of the personnel and the contents of the “general regulations of safety technology” and machine safety regulations (Maschinen-Sicherheitsverordnung - MSV) are not subject of this chapter.

Inappropriate behaviour and insufficient knowledge of hazard during repair works may cause injury to persons.

In the description of repair works, such sources of danger are marked with

---

#### CAUTION

The personnel are to be trained accordingly and requested to follow the safety rules.

### 2.7.2 Guidelines for damage prevention

The general knowledge and training of the workshop personnel and the contents of the “general regulations of safety technology” and machine safety regulations (Maschinen-Sicherheitsverordnung - MSV) are not subject of this chapter.

Inappropriate behaviour and insufficient knowledge of hazard during repair works may cause injury to persons.

In the description of repair works, such sources of danger are marked with

---

#### WARNING

While handling operating materials, take care that these are not applied to visible surfaces. Lubricants should form a thin film on the surface, surplus lubricants are to be wiped off.

### 2.7.3 Legal rules

The following rules and guidelines are valid in Austria. For other countries, follow the local regulations.

Maschinen - Sicherheitsverordnung - MSV (machine safety regulations)

### 2.7.4 Safety in the use of operating material

Dangerous operating material, in the sense of accident prevention, are all operating materials potentially explosive, oxidising, easily flammable, poisonous, dangerous to health and corrosive.

The following materials especially belong to this group:

- Engine oil
- Fuel
- Coolant
- Spirit
- Mineral oils
- Battery acid
- Anti-freeze agent
- Varnishes and diluents
- Solvents
- Fluid seals and nut locks

In case of fire of operating material do not try to extinguish the fire with water. Use carbon dioxide extinguisher or powder extinguisher. Contact fire brigade.

When operating material is spilled, e.g. in case of refuelling, it is to be absorbed by sand, soil or an appropriate bonding agent and to be disposed.



### **CAUTION**

**In order to prevent health hazards, take care of the following:**

- ▶ Avoid direct contact with dangerous operating material, as much as possible.
  - ▶ Change clothes as quickly as possible, if they are soiled with dangerous operating material.
  - ▶ Do not keep oily rags in work clothes.
  - ▶ Clean oil soiled body parts only with products friendly to skin (never use rubbing sand or solvents).
  - ▶ Never fill operating agents in beverage bottles.
-

## 2.8 Measures in case of accidents

Products	First Aid		
	Skin	Eyes	Swallowing
Diesel fuel and mineral oils	Remove clothes and clean skin thoroughly with water and soap	Rinse thoroughly with water for at least 10 minutes SEE A DOCTOR!	<p>DO NOT VOMIT</p> <p>The biggest danger after an accidental intake is the fact that liquid could get into lungs by aspiration</p> <p>DO NOT INDUCE VOMITING AND IMMEDIATELY SEE A DOCTOR!</p>
Lubricants			
Anti-freeze agents			
Brake fluid			
Battery acid			

## 3 Specifications

### 3.1 Fuel requirements

The **Steyr Motors** marine engines are designed for maximum fuel economy. To maintain optimum performance use diesel fuel according to EN 590 or equivalent to meet this specification. When temperatures are below  $-7\text{ }^{\circ}\text{C}$  ( $20\text{ }^{\circ}\text{F}$ ), use diesel fuels with additives for low temperature operation.

#### 3.1.1 How to select fuel

Fuel quality is an important factor in obtaining satisfactory engine performance, long engine life, and acceptable exhaust emission levels. Direct injected diesel engines are designed to operate on most diesel fuels marketed today. In general, fuels meeting the properties of CEC RF-03-A-84 have provided satisfactory performance.

The ASTM D 975 specification, however, does not in itself adequately define the fuel characteristics needed for assurance of fuel quality. The properties listed in the following fuel oil selection chart have provided optimum engine performance.

#### Fuel oil selection chart

Properties	Unit	Minimum	Maximum	ASTM Test procedure
Cetane number		52.5		DIN 51773
Density at $15\text{ }^{\circ}\text{C}$	$\text{kg/m}^3$	820	845	EN ISO 3675 EN ISO 12185
Distillation 250 $^{\circ}\text{C}$ 350 $^{\circ}\text{C}$ End point 360 $^{\circ}\text{C}$	% (V/V) % (V/V)	- 85 %	< 65 % 95 %	EN ISO 3405
Flash point	$^{\circ}\text{C}$	55		EN ISO 2719
CFPP (Cloud point)	$^{\circ}\text{C}$	-5 (s)	-15 (w)	
Kinematic viscosity 40 $^{\circ}\text{C}$	$\text{mm}^2/\text{s}$	2	4.50	EN ISO 3104
Sulphur content	$\text{mg/kg}$	-	10.0	EN ISO 20846 EN ISO 20884
Copper corrosion	Rating	Class 1	Class 1	EN ISO 2160
Carbon residue: Conradson number (10 % residue)	% (m/m)	-	0.30	EN ISO 10370
Ash	% (m/m)	-	0.01	EN ISO 6245
Water content	$\text{mg/kg}$	-	200	EN ISO 12937
Oxidation stability	$\text{g/m}^3$	-	25	EN ISO 12205

### 3.2 Engine oil requirements

To obtain the best engine performance and engine life, **Steyr Motors** turbo diesel engine oil SAE 10W-40 (500830) is recommended. Engine oils are specified by ACEA, API service codes and SAE viscosity numbers. If **Steyr Motors** high performance turbo diesel engine oil SAE 10W-40 is not available, it is required to use a reputable brand of engine oil labelled for correct ACEA and API as well as fulfilling SAE 10W-40, see table below.

Refer to oil identification symbol on the container.



#### **CAUTION**

**Using the incorrect engine oil can cause hazards or engine damages!**

- ▶ Use engine oil according to the specifications listed in table below.
- ▶ Observe the material safety data sheet.

Item	6 cylinder engines	4 cylinder engines
Initial filling quantity	17.0 litre (inclusive 1 litre oil filter)	11.5 litre (inclusive 1 litre oil filter)
Oil quantity between min and max on oil dipstick	3.5 litre	2.5 litre
Oil change quantity	Approx. 16.0 litre (without oil filter)	Approx. 10.5 litre (without oil filter)
Oil filter	Approx. 1.0 litre	
Oil - specification	SAE 10W-40 API: CI-4, CH-4, CG-4, CF-4, CF ACEA: E6, E7	
Recommended engine oil	Steyr Motors turbo diesel engine oil SAE 10W-40 SMO no. 500830	

During the break in period (20 hours), frequently check the oil level. Higher oil consumption is normal until cylinders are stabilized. The oil level should be maintained between the minimum and maximum mark on the dipstick. The space between the marks represents approximately 3.5 litres (3.7 quarts).

refer to **Service and maintenance schedule** for recommended oil change intervals.

---

#### **NOTICE**

Optional there are two different oil dip sticks available according to the engine storage inclination.

After the first 50 hours of operation, change the engine oil and replace the oil filter. Refer to service and maintenance schedule.

---

### Oil identification symbol

Engine oils are specified by ACEA, API service code and SAE viscosity numbers.

These may be found on the label, top of can, or oil identification symbol.

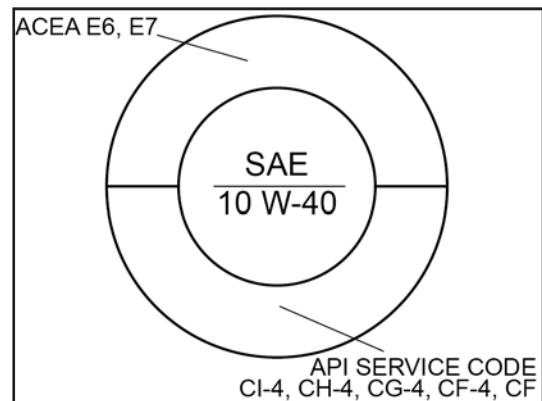

Fig. 25 Oil identification symbol

### NOTICE

Some engine oils have several ACEA / API quality ratings.

The specified ACEA /API service letter code must be among these quality ratings.

**Steyr Motors AG** has no values regarding the oil- & fuel- consumption when an untested engine oil is in use.



Fig. 26 Oil sticker

### 3.3 Engine coolant requirements

To maintain the specific functions of the engine coolant, use engine coolant according to the specifications of **Steyr Motors AG** only, see table below.



#### **CAUTION**

**Using the incorrect coolant can cause hazards or engine damages!**

- ▶ Use coolant according to the specification table below.
  - ▶ Observe the material safety data sheet.
- 

Item	Specification 6 cylinder engine	Specification 4 cylinder engine
Coolant water filling quantity	15.5 l	10.7 l
Coolant additive specification	Organic acid technology (NAP-Free)	
Water/coolant ratio	50:50 %, deionised water to be used	
Recommended coolant	Steyr Motors engine coolant – 40 C° SMO no. 500831, ready mixed	

The coolant level has to be maintained between the minimum and maximum mark on the coolant expansion reservoir. For the location of the coolant expansion reservoir see the vessel manufacturers operation manual.

---

#### **NOTICE**

The engine coolant has to be checked and replaced periodically. Refer to **Service and maintenance** schedule for detailed information.

---

---

## 4 Transport and storage

---

### CAUTION

#### **Damage due to improper transport!**

Significant damage to property and injuries to persons can occur in the case of improper transport.

- ▶ Proceed carefully when unloading the packages and on delivery and internal transport and observe the signs and notices on the packing.
  - ▶ Only use the attachment points provided.
  - ▶ Do not remove packing until just before the installation.
- 

### WARNING

#### **Risk of injuries due to lifted load!**

Improper loading can cause accidents with serious injuries or death.

- ▶ There must be no persons in the danger zone. When lifting the engine make sure that nobody is on the engine or steps under the suspended load.
  - ▶ The crane must be operated by authorised personnel, only.
  - ▶ Lifting tools and slings must be approved, tested and adequately dimensioned.
  - ▶ The engine must only be lifted at the intended lifting points.
  - ▶ Let the engine swing out till the balance, condition and position of slings are satisfying and lift the engine slowly to the required height for loading.
  - ▶ Wear the appropriate personal protective equipment.
-

### 4.1 Transport inspection

Check the delivery immediately on receipt for completeness and transport damage.

If externally detectable transport damage is found, proceed as follows:

- Do not accept the delivery, or only with reservation.
- Record the extent of transport damage in the transport documents or on the delivery note of the forwarding agent.
- Start complaints procedure.

---

#### Information

Claim any damage as soon as it is detected!

Compensation claims can only be submitted within the applicable complaints periods.

---

## 4.2 Packing

---

### **NOTICE**

#### **Material damage due to incorrect transport packaging!**

Using an incorrect transport packaging can cause material damage at the engine.

- ▶ Use the original transport packaging.
- 

### 4.2.1 Concerning packing

The individual packages have been packed to match the transport conditions that can be expected. Only environmentally friendly materials were used for packing.

The packing has the function of protecting the individual components against damage, corrosion, etc., until they are finally assembled. Therefore the packing material must not be damaged and should only be removed just before assembly takes place.

---

### **NOTICE**

#### **Material damage due to incorrect transport packaging!**

Using an incorrect sea transport packaging can cause material damage at the engine.

- ▶ Use a correct sea transport packaging.
- 

### 4.2.2 Handling packing materials

If there is no returns agreement for the packing, separate materials according to type and size and direct to further use or recycling.

---

#### **Environment**

#### **Environmental damage caused by incorrect waste disposal!**

Packing materials are valuable raw materials and can continue to be used in many cases or sensibly reconditioned and recycled.

- ▶ Dispose packing materials environmentally.
  - ▶ Follow the locally valid waste disposal regulations. If necessary employ a special waste disposal company to organise the disposal of packing material.
-

### 4.3 Transport

---

#### **WARNING**

##### **Risk of injuries due to lifted load!**

Improper loading can cause accidents with serious injuries or death.

- ▶ There must be no persons in the danger zone. When lifting the engine make sure that nobody is on the engine or steps under the suspended load.
  - ▶ The crane must be operated by authorised personnel, only.
  - ▶ Lifting tools and slings must be approved, tested and adequately dimensioned.
  - ▶ The engine must only be lifted at the intended lifting points.
  - ▶ Let the engine swing out till the balance, condition and position of slings are satisfying and lift the engine slowly to the required height for loading.
  - ▶ Wear the appropriate personal protective equipment.
- 

#### **NOTICE**

Two lifting eyes are mounted on top of the engine. Use the lifting eyes only for lifting the engine to avoid damage.

Be sure that the lifting means are positioned vertically. See illustration below for correct positioning of the lifting means.

- ▶ Use a special tool for the correct vertical alignment of the lifting means.
- 

#### **6 cylinder engine**

1. Fasten appropriate lifting means (up to 500 kg) to the lifting eyes **(1)**.
2. Wait until the engine completed its swing. Lift and transport engine.

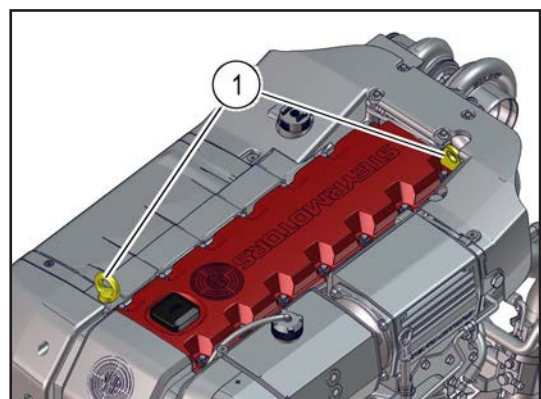

Fig. 27

### 4 cylinder engine

1. Fasten appropriate lifting means (up to 500 kg) to the lifting eyes **(1)**.
2. Wait until the engine completes its swing. Lift and transport engine.

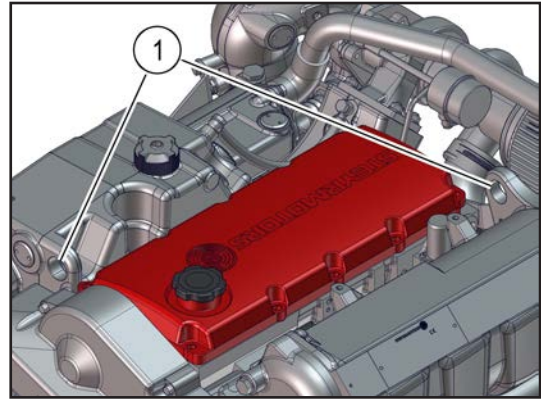

Fig. 28

Store new engines under the following conditions:

- Store in original packaging.
- Do not store outdoors.
- Store dry and dustfree.
- Do not expose to any aggressive media.
- Protect against direct sunlight.
- Avoid mechanical vibrations.
- Storage temperature: 15 to 35 °C.
- Relative humidity: max. 60 %.
- All openings (e.g. intake air, exhaust, etc.) need to be closed with protective caps.
- In the case of storage for longer than 3 months, check the general condition of all parts and the packing regularly. If required, refresh or renew the anti-corrosion protection.

Storage of the engines up to 6 months is possible under the above conditions.

### CAUTION

#### Damage due to improper storage!

Parts of the engine can corrode and become nonfunctional in the case of too high relative humidity or air containing salt.

- ▶ In the case of storage for longer than 6 months, contact the nearest **Steyr Motors** service partner in order to ensure suitable precautions.

### 4.4 Storage

---

#### **NOTICE**

##### **Damage due to improper storage.**

- ▶ Observe storage instructions.
- 

#### 4.4.1 Storage conditions

An adequate preservation of the engine will contribute to an efficient and troublefree operation in the long term.

Consult an authorized **Steyr Motors AG** service partner to get professional assistance in performing a proper off season storage.

1. Change motor oil and oil filter.
  2. Change fuel filter.
  3. Check air filter.
  4. Check coolant (closed circuit).
  5. Drain engine's raw water system.
- 

#### **NOTICE**

**Engine damage. If the raw water is not completely removed from the engine, expensive freeze damage may result.**

- ▶ Drain engine's raw water system completely.
- 

6. Drain raw water system from boat and driving system (consider manufacturer's instructions as to storage).
7. Change gear oil or lubricant as per manufacturers specification.
8. Disconnect battery and store it in a dry and frost free place.
9. Spray engine outside with corrosion prevention oil.
10. Ventilate engine compartment and bilge.

#### 4.4.2 Start-up after storage

A correct start-up of the engine will contribute to an efficient and troublefree operation in the long term.

Your **Steyr Motors AG** service partner will be glad to advise you or provide expert services.

1. Check condition of hoses and hose clamps.
2. Clean battery terminals.

---

### **NOTICE**

**Incorrect connection of battery terminals can damage the electronic system.**

- ▶ Connect RED cable to the positive terminal and then BLACK cable to the negative terminal.

- 
3. Grease outer sides of terminals.
  4. Open fuel stop valve and check all fuel lines for leakage.
  5. Thoroughly check the boat and engine for slack and missing screws or nuts.
  6. Pump the bilge dry and clean the engine compartment.
  7. Complete the raw water system.
  8. Open the raw water inlet.

---

### **NOTICE**

**Insufficient raw water supply can damage the engine and the raw water pump.**

- ▶ Ensure sufficient raw water supply.

- 
9. Perform a test run.
    - Start engine
    - Check voltmeter
    - Check oil pressure
    - Check water temperature
    - Make sure that all systems are working properly
  10. Check all parts for oil-, fuel- or water leakage.

---

### **i** Information

For additional Information regarding engine preparation for long term preservation, consult your **Steyr Motors AG** - service partner.

---

### 4.5 Extended storage preservation procedure

---

#### **NOTICE**

Valid for all 4 and 6 cylinder marine engine models!

Brand new or winter storage!

---

#### **Warranty** - For eligible engines

- **Steyr Motors** engines standard 12 month warranty begins on date of dispatch from the factory.
- Preserving the engine as described below delays start of warranty by 12 months from date of 1<sup>st</sup> Preservation.
- Performing the 2<sup>nd</sup> Preservation delays start of warranty by a further 12 months.
- **Steyr Motors** engines can be preserved from the factory for a maximum of 36 months from date of dispatch from factory, (initial - 12 months / 1<sup>st</sup> Preservation - 12 months / 2<sup>nd</sup> Preservation - 12 months).
- Commissioning should be performed within 30 hours / 30 days of de-preservation and notified to **Steyr Motors** within 60 days of de-preservation.
- Preservation must be notified to **Steyr Motors** within 60 days.
- Commissioning, preservation, de-preservation should be sent to:  
[commissioning@steyr-motors.com](mailto:commissioning@steyr-motors.com)

#### **Required tools:**

- Oil change tools / containers
- Coolant containers - if draining coolant
- Fuel system - supply / return hoses, fuel container
- Battery
- Battery connection cables

**Consumables / parts required:**

---

**NOTICE**

For the most up to date information on consumables approved by SMO please refer to our website [www.steyr-motors.com](http://www.steyr-motors.com).

---

- **Protection wax** (external corrosion protection)
  - quantity: 400 ml
- **Anti-corrosive oil** (internal corrosion protection)
  - quantity: 300 ml
- **Fuel additive**
  - quantity: 100 ml
  - must be specified to stabilise fuel for greater than or equal to 12 months.
- **Diesel EN 590**

**4.5.1 Preservation**

**4.5.1.1 1<sup>st</sup> Preservation procedure**

1. Remove packing from around engine.

---

**NOTICE**

**Retain packing for reuse!**

---

2. Connect instrument panel.
3. Connect electrical supply.
  
4. Remove poly-v belt.

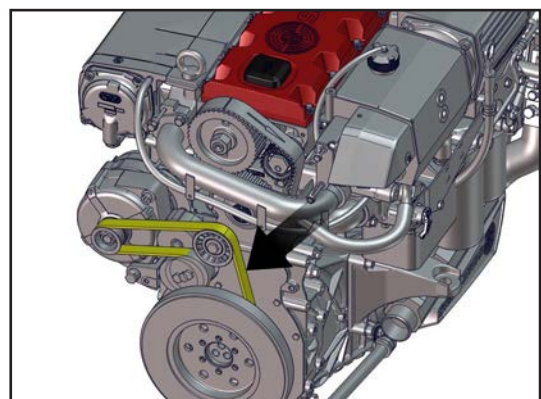

Fig. 29

## Transport and Storage

5. For storage longer than 6 months, it is recommended to remove raw water pump.
6. Remove raw water pump impeller.
7. Store raw water pump impeller in airtight package.

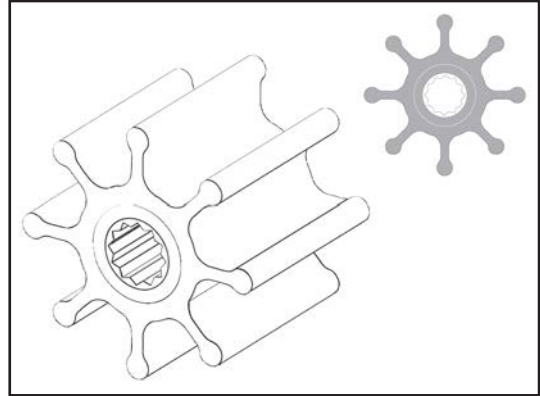

Fig. 30

### Remove camshaft housing cover

8. Unscrew 14 hexagon screws (WS 10).
9. Remove camshaft housing cover.

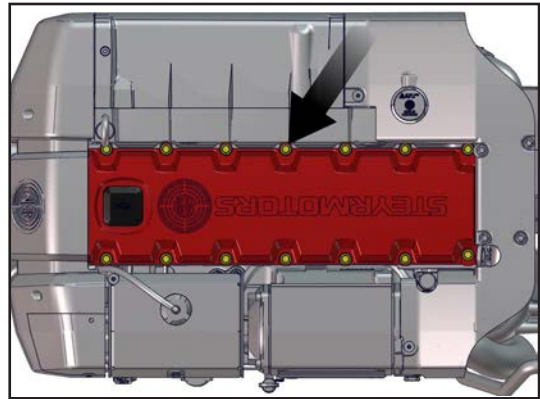

Fig. 31

10. Turn crankshaft 2 turns clockwise.

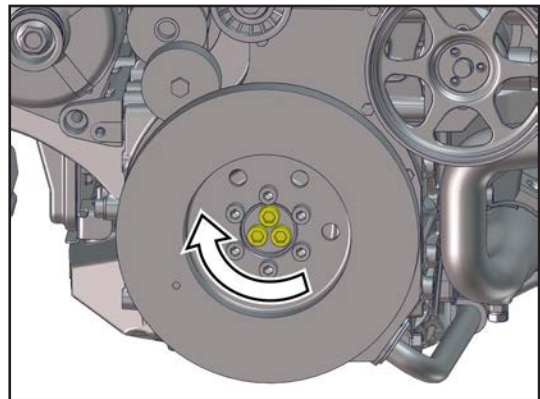

Fig. 32

11. Move control rack e. g. with a screwdriver and check for ease of movement of the control gear rods.

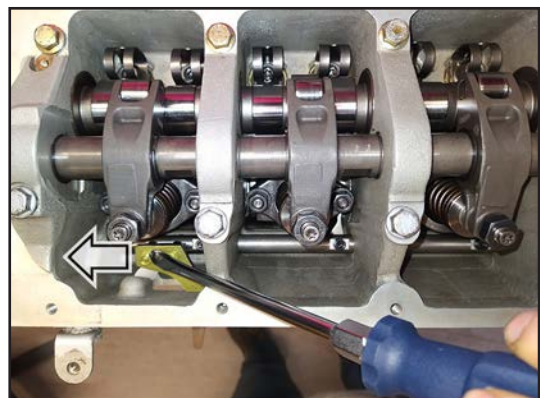

Fig. 33

**NOTICE**

Check ease of movement of the control gear rod (1) for each cylinder.

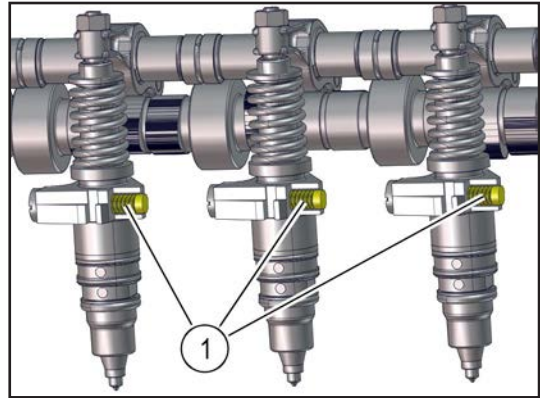

Fig. 34

Mount camshaft housing cover

12. Put camshaft housing cover onto camshaft housing.
13. Tighten with 14 hexagon screws (WS 10) with a torque of  $9.5 \pm 0.5 \text{ Nm}$ .

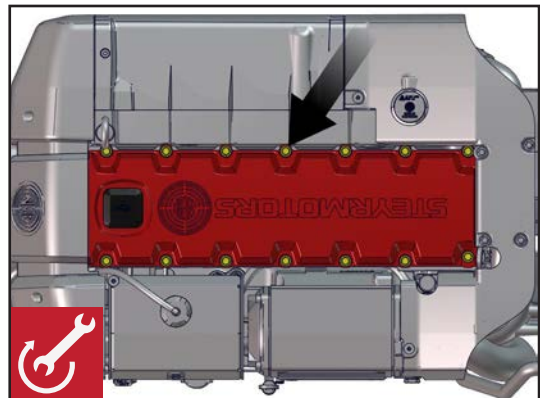

Fig. 35

14. Add 300 ml anti-corrosive oil to engine oil.

**NOTICE**

Oil level may not exceed MAX!

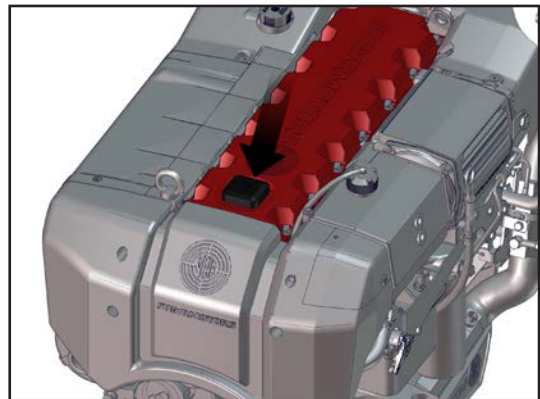

Fig. 36

15. Mix fuel stabiliser with fresh diesel in separate small fuel canister to specified ratio.

**Ratio:** 100 ml fuel stabiliser : 5 litres EN 590 Diesel

16. Connect fuel return line (ID = 8 mm) (2) ...

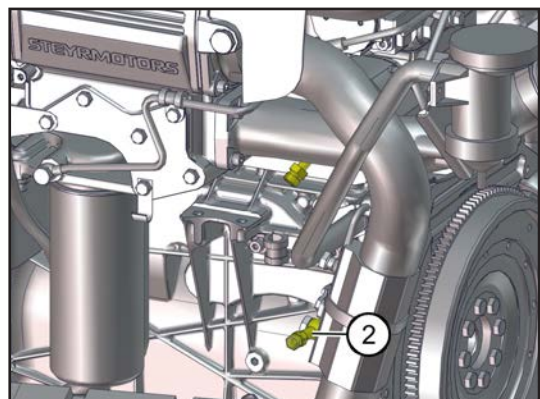

Fig. 37

17. ... and fuel supply line (ID = 16 mm) **(1)** ...

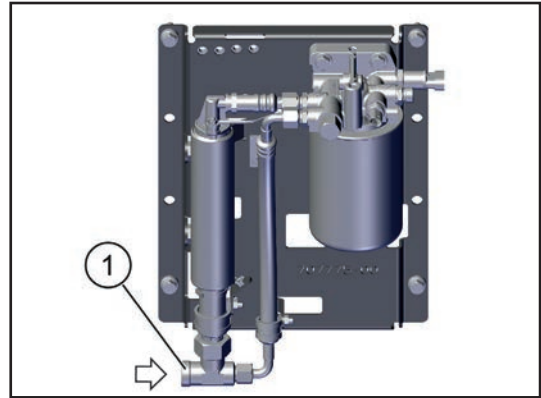

Fig. 38

18. ... to separate small fuel canister **(3)**.

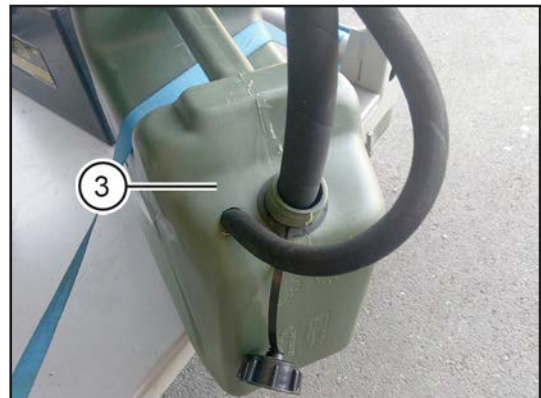

Fig. 39

19. Run engine at idle or maximum 1500 rpm (without load) until an operating temperature of 60 °C is reached.

---

### **NOTICE**

Let engine cool down to 40° C before the next steps.

---

20. Remove fuel return line and fuel supply line.

21. Remove air filter.

22. Store air filter in airtight package.

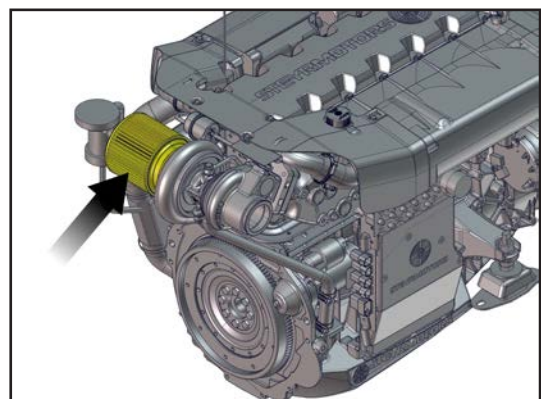

Fig. 40

23. Spray anti-corrosive oil into air intake and exhaust side to preserve the turbo charger.

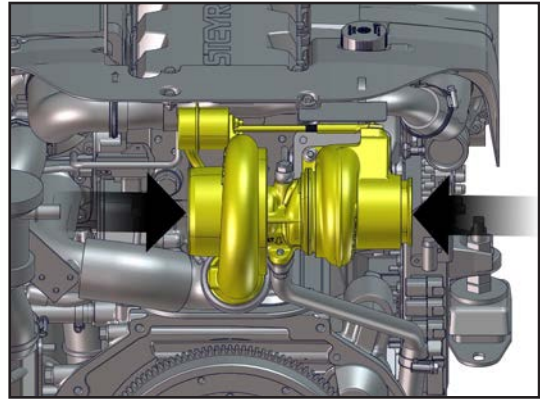

Fig. 41

24. Close (seal) all openings [oil separator (as shown), intake, exhaust, fuel lines, turbo charger] with protection caps.
25. Coat unpainted parts of engine assembly with protection wax.
26. Repack engine in original packing.
27. Store engine according to "4.4.1 Storage conditions".

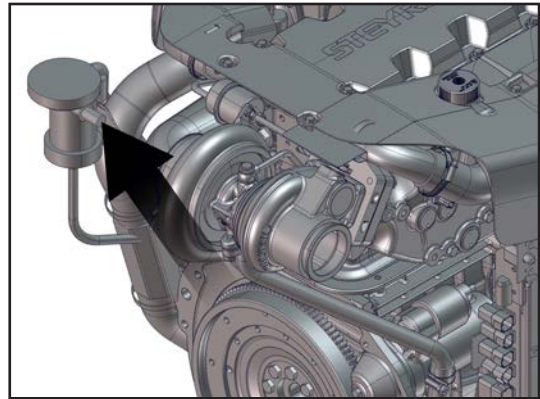

Fig. 42

## NOTICE

If engine has been run with raw water, flush raw water system with nontoxic, environmental-friendly antifreeze such as propylene glycol before storage.

Sticker

## NOTICE

Register preservation with commissioning: send e-mail to: [commissioning@steyr-motors.com](mailto:commissioning@steyr-motors.com)

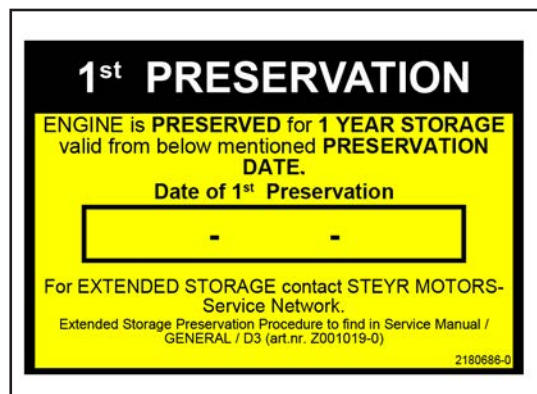

Fig. 43

28. The engine is now preserved for one more year.  
This procedure is repeatable up to a maximum of two times, giving a shelf life of up to three years.

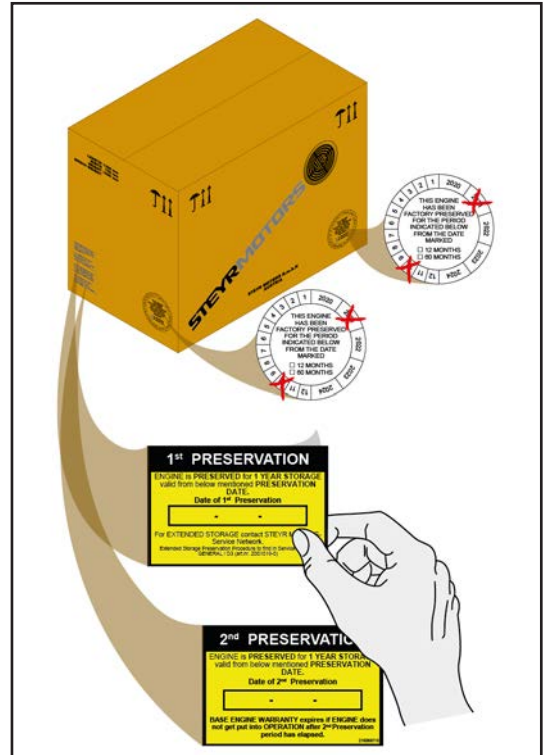

Fig. 44

### NOTICE

When commissioning or running an engine that has been preserved as stated above the engine will run roughly and smoke for the first few minutes. Do not be alarmed as this is normal until the deposits of the preservation materials have cleared.

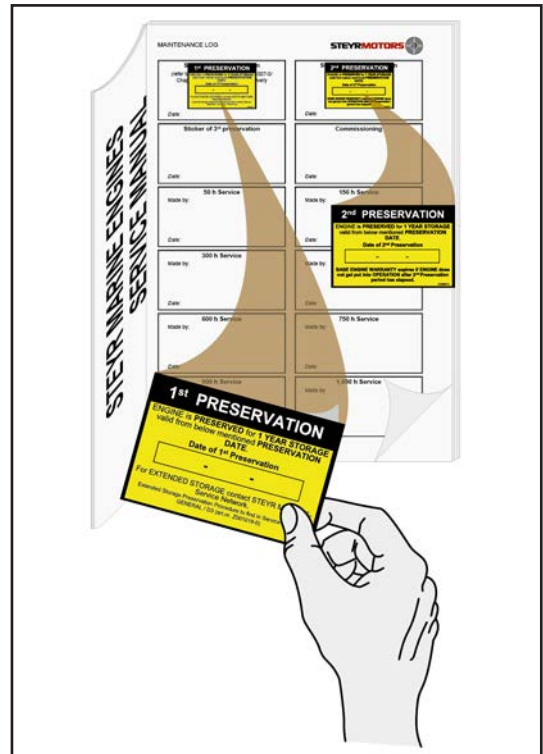

Fig. 45

#### 4.5.2 2<sup>nd</sup> Preservation

1. Change engine oil and engine oil filter as described in service manual.
2. Drain and refill closed cooling system with fresh coolant.
3. Reinstall air filter.

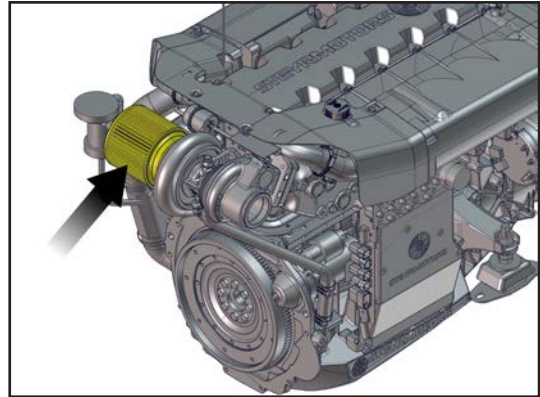

Fig. 46

Follow the steps 1st Preservation procedure, refer to “4.5.1.1 1st Preservation procedure”.

### **NOTICE**

See maintenance and service parts list for model specific part numbers and quantities!

<https://www.steyr-motors.com/>

- Oil filter
  - Fuel filter
  - Steyr Motors engine oil
- 

Sticker

### **NOTICE**

Register preservation with commissioning e-mail to: [commissioning@steyr-motors.com](mailto:commissioning@steyr-motors.com)

---

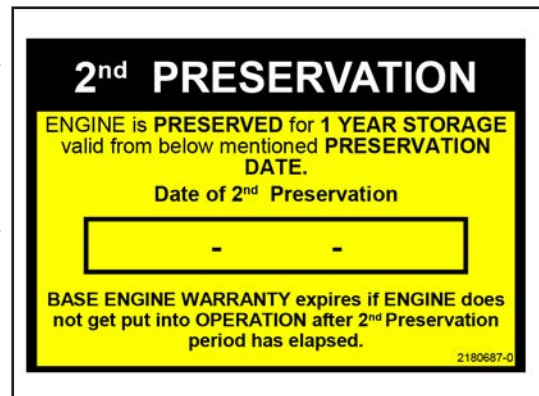

Fig. 47

### 4.5.3 De-preservation

#### 4.5.3.1 De-preservation

### **NOTICE**

See maintenance and service parts list for model specific part numbers and quantities!

<https://www.steyr-motors.com/>

- Oil filter
  - Fuel filter
  - Steyr Motors engine oil
-

### 4.5.3.2 De-preservation procedure

- Install engine as per instructions in installation guide, confirm the following:
  1. Connect instrument panel.
  2. Remove protection caps.
  3. Fit new fuel filter.

---

#### **NOTICE**

Fill fuel filter with fresh clean diesel before fitting!

---

4. Fuel system connected and primed with fresh clean diesel.
5. Connect battery cable.
6. Reinstall raw water pump impeller in raw water pump.

---

#### **NOTICE**

If cracks or damage is visible install **new** impeller!

---

7. Reinstall raw water pump.
8. Reinstall air filter.

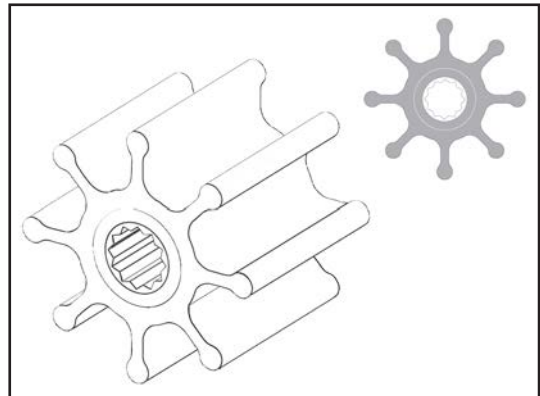

Fig. 48

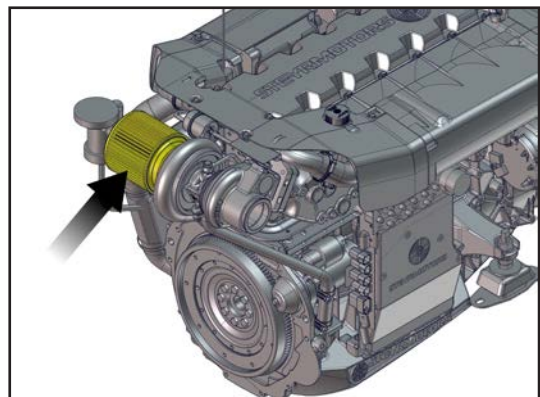

Fig. 49

9. Reinstall poly-v belt.

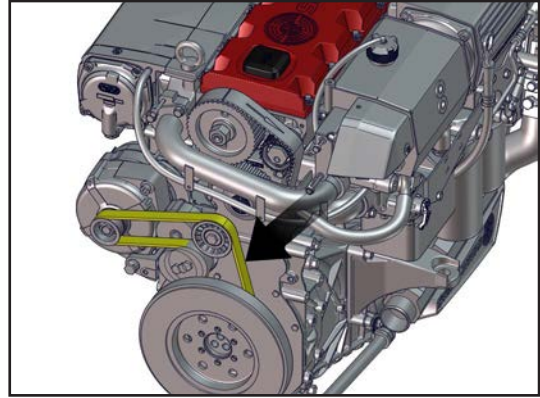

Fig. 50

10. Connect fuel return line to separate small fuel canister.

11. Turn ignition "On" 10 seconds three times. Allow fuel rail and engine mounted fuel filter to fill with fresh clean Diesel.

12. Reconnect fuel return line to fuel tank return.

13. Run engine at idle or maximum 1500 rpm to obtain operating temperature.

14. Replace oil filter.

15. Change engine oil as described in service manual.

16. For new or used engines always follow "Engine break-in procedure" as specified in operators manual after de-preservation.

For new engines proceed with sea-trials and commissioning procedure.

## 5 Quality directives for assembly

For the assembly of spare parts, the manufacturer's instructions as well as legal regulations are to be considered. If repaired components or units are used as spare parts, the machining directives of the manufacturer are to be kept.

Safety components are components which due to a change of their initial form, their surface and material resistance will no more guarantee operating reliability and traffic safety and may cause considerable material damage or even personal damage. Such components may only be repaired or assembled if all testing and measuring instruments required for determination of component quality with respect to proper conditions of installation are guaranteed.

Model-dependent units and parts are components which are subject to approval in the course of standardization of the boat. Their failure means a risk for traffic safety.

Parts subject to design approval are components which are of particular importance for traffic safety and operating reliability, and which are approved with regard to their effectiveness, irrespective of the vessel. In case of an exchange, such components may be replaced by design-approved parts only.

### 5.1 Specification of spare parts

Your **Steyr Motors** diesel engine with direct fuel injection has been designed for high output. Only use genuine - **Steyr Motors** - spare parts to avoid any loss of efficiency. You, therefore, should insist on the known quality of genuine - **Steyr Motors** spare parts and should never use parts of unknown quality.

Chapter 20 (Appendix) contains a proposal on spare parts.

### 5.2 Workshop profile

Irrespective of the individual repair steps and legal regulations, the workshop should meet the following requirements:

- Clean, dry and dust-free ambience / no metal debris
- Lifting device (crane) with a carrying capacity of at least 5 000 N
- Cleaning accommodation (washbasin) for contaminated components
- Tools pertaining to commercial customs
- Proper testing and measuring appliances
- Collecting trays for fuel and oil.

Depending on the repair step to be carried out, tools according to the tool catalogue are to be procured. In addition, the procurement and stock of required fuel and oil, spare- and wear parts (e.g. seals, filters, anodes,..) are to be considered.

For authorized dealers and workshops, a minimum standard as to tools of stage 1 / service tools is required.

## 5.3 Assembly of plug connections

### 5.3.1 Plug connections for steel tube

For tubes with an outside diameter up to 10 mm it is recommended to screw the relevant sockets of the plug connections into the respective devices, and to carry out assembly of the piping on the installation site.

The prepared end of tube with union nut and cutting ring is plugged directly into the threaded socket and the union nut is done up by hand to the tangible stop on the cutting ring.

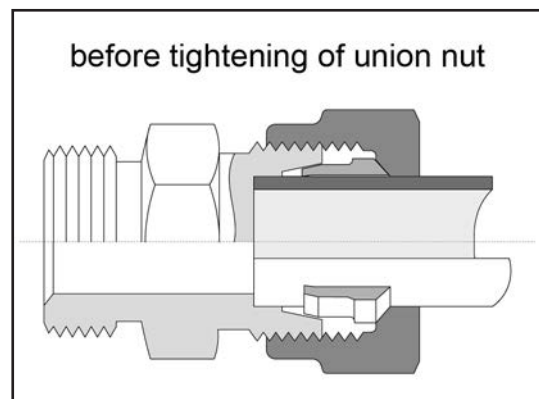

Fig. 58

Now press the tube against the stop in the threaded socket, and tighten the union nut for approx. one  $\frac{3}{4}$  turn.

In the course of this, the tube must not turn. Since the cutting ring has now picked up the tube, a further pressing of the tube is unnecessary. Final tightening is done by repeated screwing down of the union nut for approx. 1 turn.

After this, disengage the union nut and check if the cutting ring's edge has penetrated the outer skin of the tube and if the collar in front of the edge is visible.

If necessary, the union nut is to be tightened once again. It is insignificant if the cutting ring at the end of tube can be turned.

After completion of the connection as well as after any loosening, tighten the union nut by means of a standard wrench, without increased expenditure of energy.

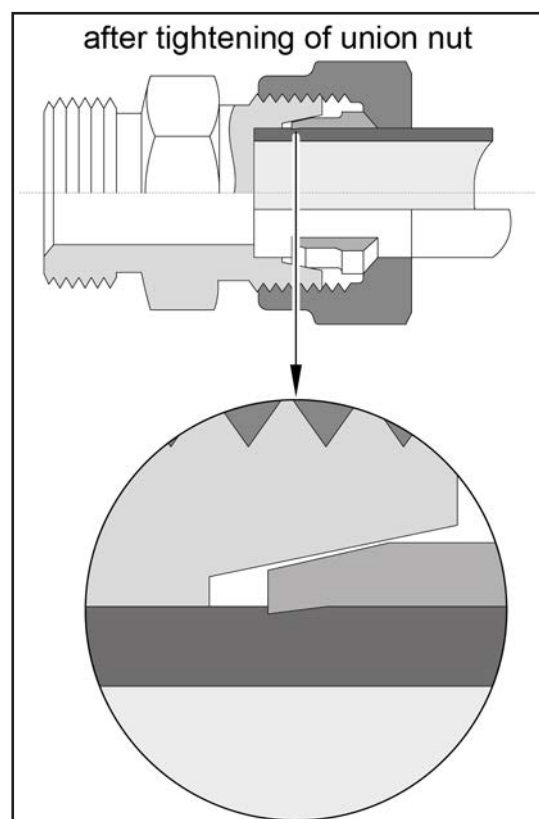

Fig. 59

### 5.3.2 Plug connection for plastic tube

For tubes with an outside diameter up to 10 mm it is recommended to screw the relevant sockets of the plug connections into the respective devices, and to carry out assembly of the piping on the installation site. The end of tube with socket and union nut is done up by hand to the tangible stop on the cutting ring. Now press the tube against the stop in the threaded socket and tighten the union nut with the torque specified. In the course of this, the tube must not turn.

### 5.3.3 Checking of plug connections

After having tightened the union nut, unscrew it again and check if the cutting edge of the cutting ring has penetrated the outer skin of the tube and if the elevated collar (visible collar) **(1)** in front of the edge is visible.

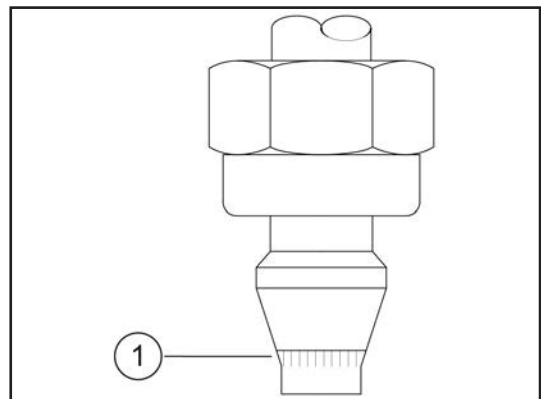

Fig. 60

### 5.3.4 Assembly of Raufoss plug systems

Before insertion, mark the plastic tube **(1)** at gape "X" **(2)**, depending on its diameter "d", and then push it into the socket **(3)** up to this mark.

Afterwards check clamping of the plastic tube by a quick traction in direction "B".

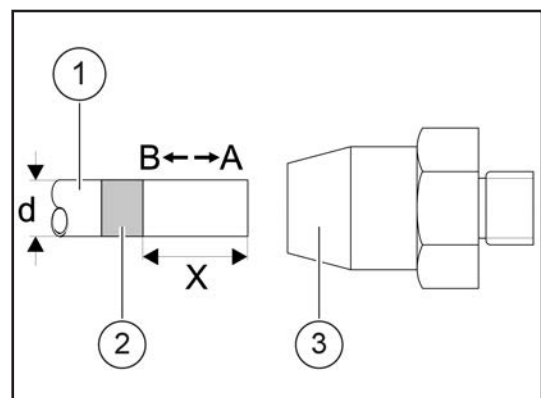

Fig. 61

### 5.3.5 Sealing of screwed pipe joints

Before assembly of the plug connections, thinly coat the outer side of the cutting ring with a "sealing agent for screwings" **(1)**.

For screwed pipe joints of hydraulic piping, coat the point of contact tube: screwed pipe joint with "standard grease" **(2)**.

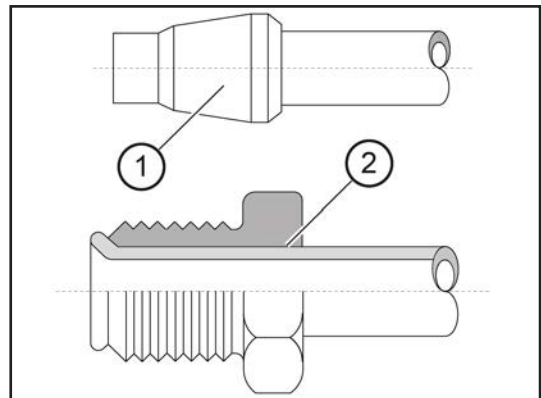

Fig. 62

### NOTICE

- ▶ Grease and sealing agents must not enter into piping!

### 5.3.6 Tightening torques

Cutting ring connections for steel tubes:

Tube	Torque
6	10 - 12 Nm

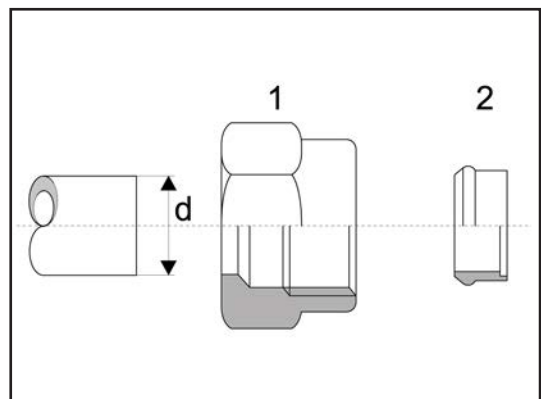

Fig. 63

Cutting ring connections for plastic tubes:

Tube	Torque
6	16 - 20 Nm
8	25 - 30 Nm

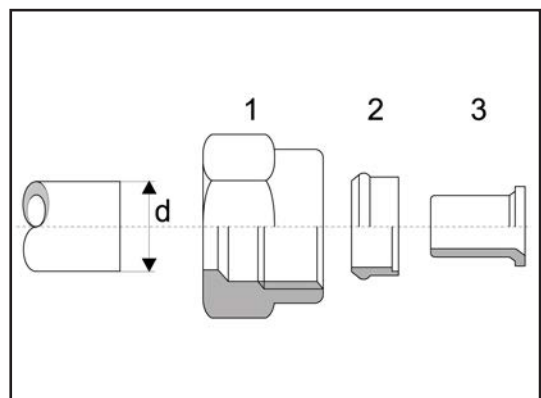

Fig. 64

### NOTICE

Absolutely use slip-on sleeves!

Clamping ring connections for plastic tubes:

Tube	Torque
12	30 - 50 Nm

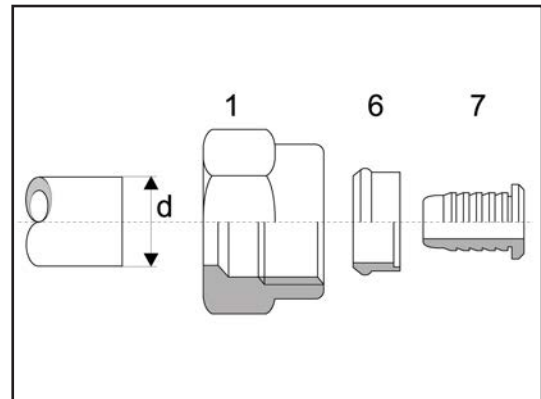

Fig. 65

Screwed pipe-joints in aluminium housings:

Thread	Torque
M10 x 1	20 Nm
M12 x 1.5	26 Nm
M14 x 1.5	28 Nm
M16 x 1.5	35 Nm
M18 x 1.5	38 Nm
M22 x 1.5	40 Nm
M26 x 1.5	50 Nm

### 5.3.7 Pipe relaying

During the assembly of pipings, ensure non-chafing and non-twisting relaying, especially for plastic tubes.

Grooves or other damages of the tube surface are to be avoided.

Damaged tubes are to be exchanged.

If plastic tubes are clamped with cable bond, it is to be ensured that the tubes are not constricted.

Relaying is to be done with sufficient safety distance to chafe marks. In case of possible chafing, use an edge protection or a spacer.

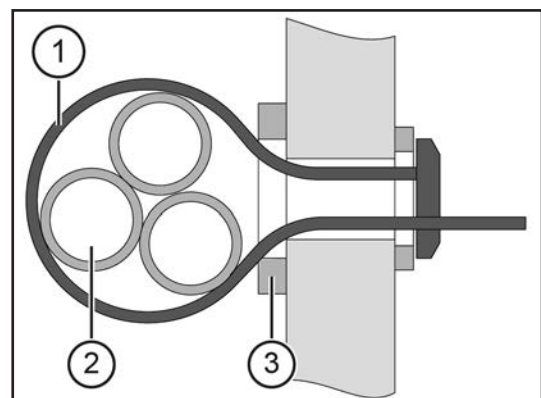

Fig. 66

## 5.4 Electrical connections

Indication for correctly connected mating connectors is an audible click!

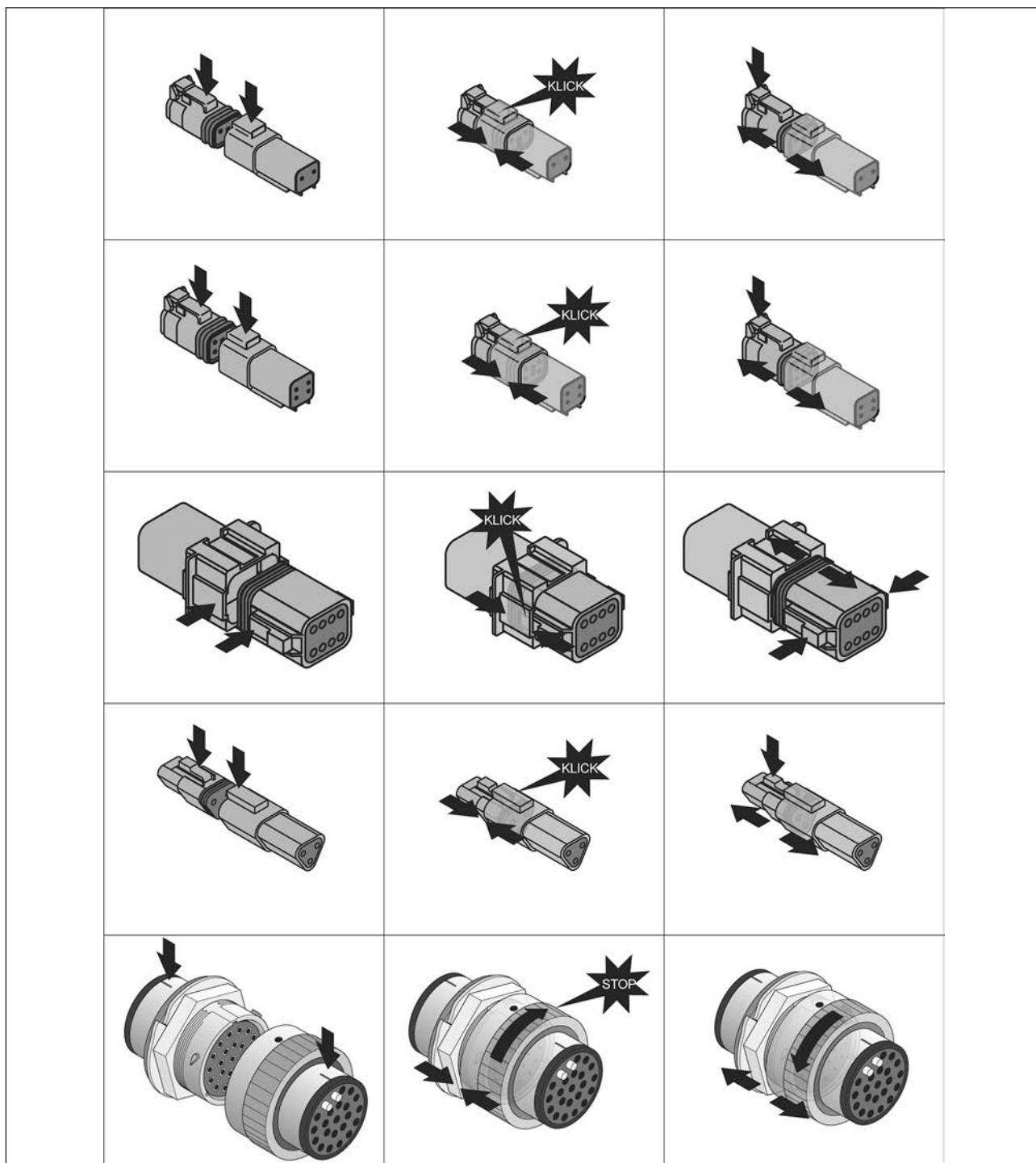

Fig. 67

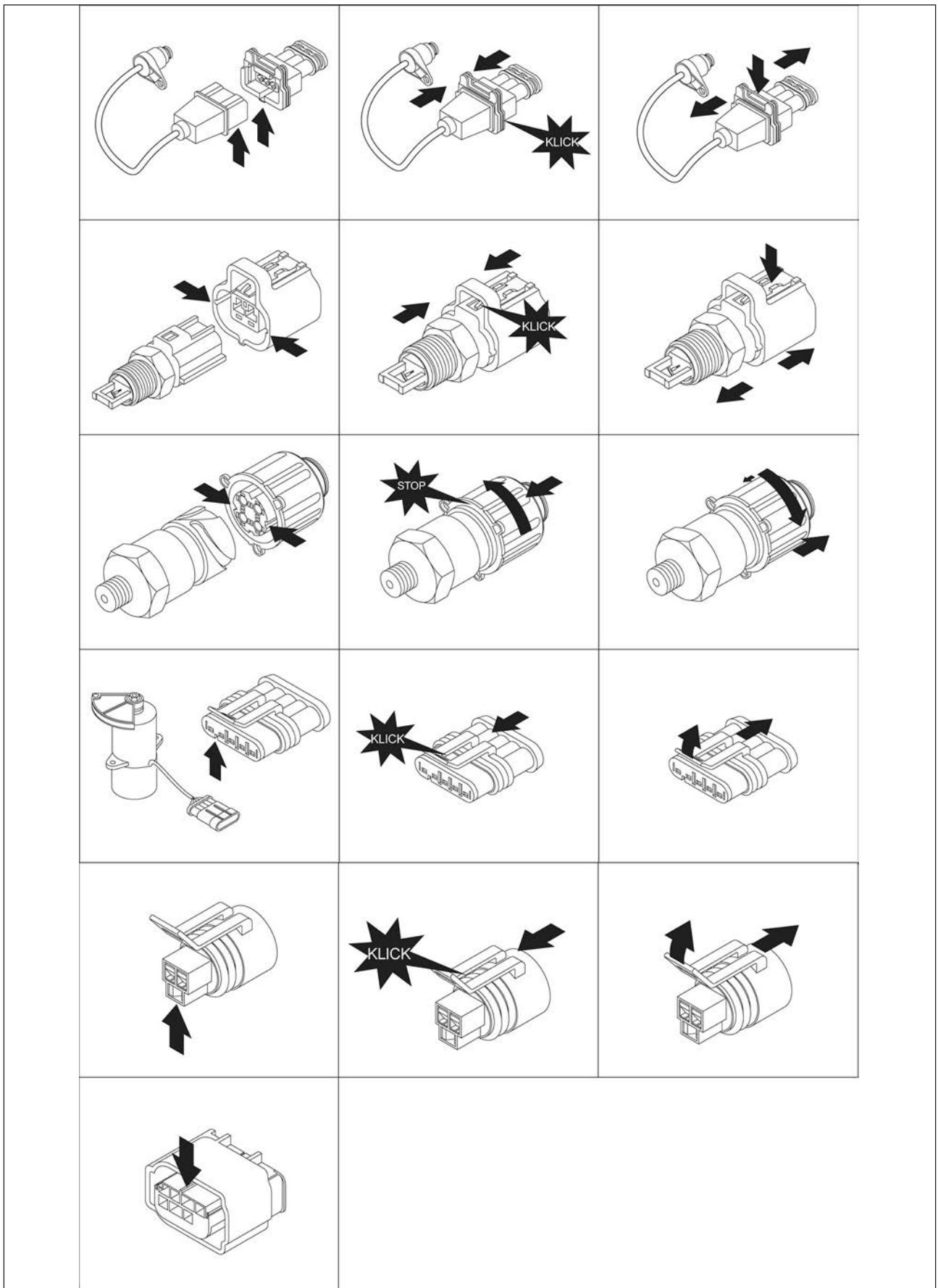

Fig. 68

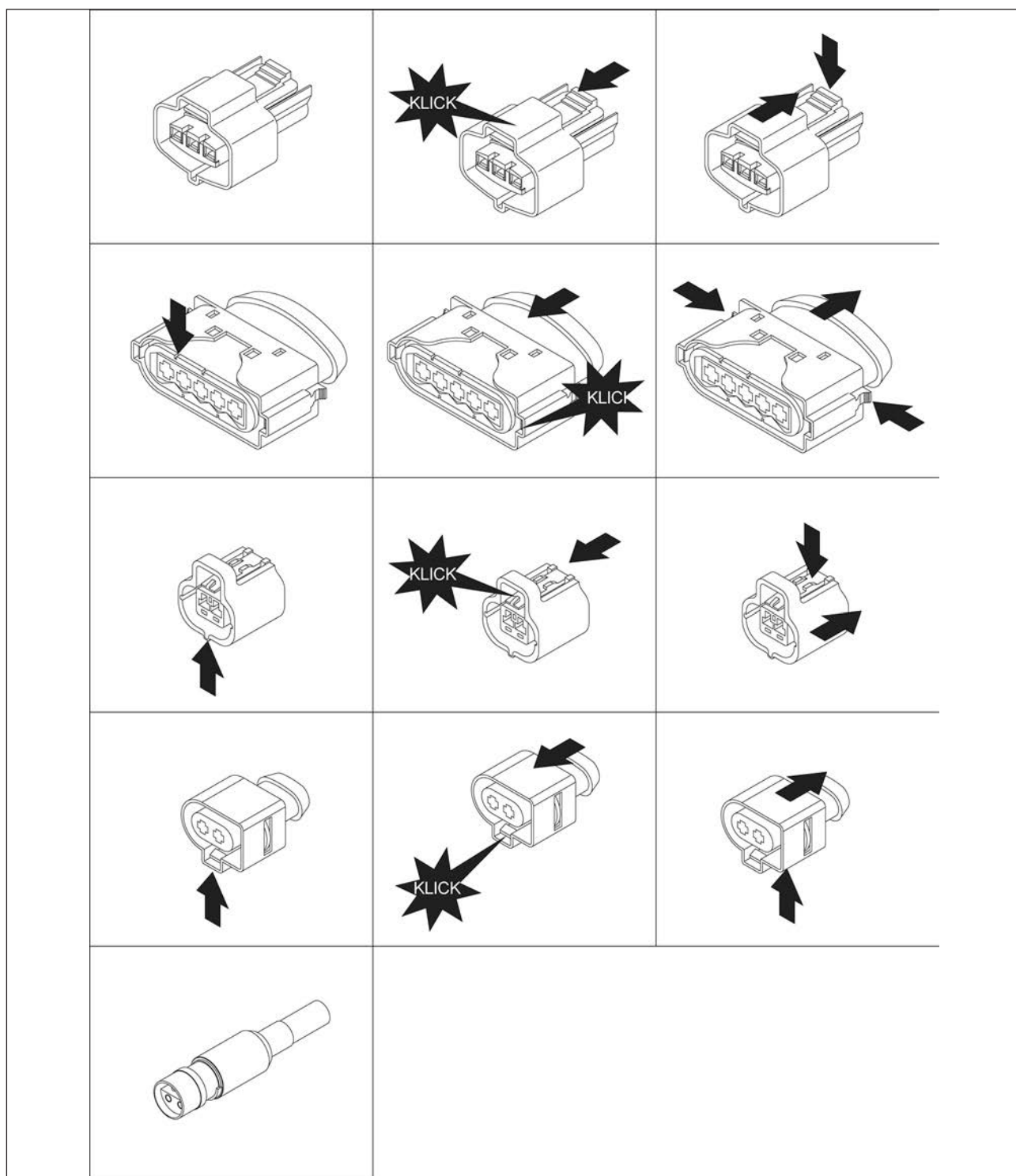

Fig. 69

### 5.4.1 Tightening torques for electrical connections

Thread	Torque
M5	6 Nm
M6	8 Nm
M8	11 Nm
M10	16 Nm

## 5.5 Tightening torques

The values in this table refer to industrial standards and are to be applied in case of no indication of specific tightening torques.

For studs, the tightening torques are to be reduced by 50 %.

$\mu$ total *)	0.100			$\mu$ total	$\mu$ total *)			$\mu$ total	0.140		
	MA in Nm				MA in Nm				MA in Nm		
Grade of strength	8.8	10.9	12.9	Grade of strength	8.8	10.9	12.9	Grade of strength	8.8	10.9	12.9
Nominal Ø	Metric control thread			Nominal Ø	Metric control thread			Nominal Ø	Metric control thread		
M 4	2.4	3.3	4	M 4	2.7	3.88	4.6	M 4	2.9	4.1	4.9
M 5	4.9	7	8	M 5	5.5	8	9.5	M 5	6	8.5	10
M 6	8	12	14	M 6	9.5	13	16	M 6	10	14	17
(M 7)	13	19	23	(M 7)	15	22	26	(M 7)	16	23	28
M 8	20	28	34	M 8	23	32	39	M 8	25	35	41
M 10	40	56	67	M 10	46	64	77	M 10	49	69	83
M 12	69	98	115	M 12	80	110	135	M 12	86	120	145
M 14	110	155	185	M 14	125	180	215	M 14	135	190	230
M 16	170	240	285	M 16	195	275	330	M 16	210	295	355
M 18	235	330	395	M 18	270	390	455	M 18	290	405	485
M 20	330	465	560	M 20	385	540	650	M 20	410	580	690
M 22	445	620	750	M 22	510	720	870	M 22	550	780	930
M 24	570	800	960	M 24	660	930	1100	M 24	710	1000	1200
M 27	840	1200	1400	M 27	980	1400	1650	M 27	1050	1500	1800
M 30	1150	1600	1950	M 30	1350	1850	2250	M 30	1450	2000	2400

### Stainless steel

Nominal Ø	Metric control thread			Nominal Ø	Metric control thread			Nominal Ø	Metric control thread		
M 8x1	22	30	36	M 8x1	25	35	42	M 8x1	27	38	45
M 10x1,25	42	59	71	M 10x1,25	49	68	82	M 10x1,25	52	73	88
M 12x1,25	72	100	120	M 12x1,25	88	125	150	M 12x1,25	90	125	150
M 12x1,5	76	105	130	M 12x1,5	83	115	140	M 12x1,5	95	135	160
M 14x1,5	120	165	200	M 14x1,5	140	195	235	M 14x1,5	150	210	250
M 16x1,5	180	250	300	M 16x1,5	210	295	350	M 16x1,5	225	315	380
M 18x1,5	260	365	435	M 18x1,5	305	425	510	M 18x1,5	325	460	550
M 20x1,5	360	510	610	M 20x1,5	425	600	720	M 20x1,5	460	640	770
M 22x1,5	480	680	810	M 22x1,5	570	800	960	M 22x1,5	610	860	1050
M 24x2	610	860	1050	M 24x2	720	1000	1200	M 24x2	780	1100	1300
M 27x2	900	1250	1500	M 27x2	1050	1500	1800	M 27x2	1150	1600	1950
M 30x2	1250	1750	2100	M 30x2	1450	2050	2500	M 30x2	1600	2250	2700

If the tightening torque of a screw connection is not achieved, the strength of the screw / nut is insufficient or the ratio of friction does not correspond. In any of these cases, the screw / nut is to be exchanged.

\*)  $\mu$  total = total friction coefficient

### 5.5.1 Checking of torque wrench

The torque wrench requires regular checking as to the values adjusted. For signalling torque wrenches the release value is tested, and for measuring torque wrenches the scale accuracy is tested.

### 5.6 Nondestructive testing of materials

To detect and locate surface cracks, nondestructive testing based on the colour penetration testing process is recommended.

In this case, the work piece is sprayed or coated with a penetrating agent, and after drying a developer is sprayed on. After a development period of approx. 10 min., defects on the work piece appear as points or lines.

### 5.7 Use of adhesive and sealing materials

The workshop manual names adhesive and sealing materials for the repair of engines and aggregates, which may be used at operating temperatures up to 150° C and with mediums such as water, cooling and hydraulic liquids, engine and transmission lubricants as well as fuels.

#### **Solvent free sealing material**

Hardening without loss in volume; tightening of screw joints hence not required.

Anaerobic sealing materials are used for securing, fixing and sealing, and will only harden with exclusion of air.

#### **Sealing material containing solvent**

Their volatile ingredients will cause a loss of volume during hardening. For repair works, their exhaust period is to be considered. If such sealing material is used, the workshop manual will contain a particular reference.

## 5.8 Solvent free sealing materials

### Silicon sealing materials

Consist of silicon and fillers, and are solvent-free.

From the tube or cartridge, the product is applied in a straight line on the cleaned surface.

Residues of sealing material are removed by means of cleaning agent.

Silicon sealing material is to be stored at temperatures below 30° C.

### Anaerobic sealing materials

Consist of single-component synthetic in fluid form. The product is applied on the assembly parts and remains fluid as long as it is in touch with the ambient air (oxygen). Only as soon as the parts are assembled, the chemical reaction, the transformation of fluid into a synthetic built up by molecular chains, begins through exclusion of atmospheric oxygen and through metal contact.

Any surplus remaining after assembly or being forced out of the connection remains fluid and can be removed easily.

#### 5.8.1 General directions for use of anaerobic sealing materials

### Cleanliness of components

Non-metallic surface protection must be removed. In case of repair works, soiled and oily components are to be cleaned and residues of adhesive synthetic are to be removed. Tap-holes are recut with an appropriate tap and blown off with compressed air.

If solvents or degreasing agents are used for cleaning, make sure that they have volatilized before application of the synthetic.

### Storage

At temperatures below 28° C, 1 year maximum.

### Directions for securing (S)

Designation: **SM** Securing medium tight (the connection is to be loosened without problems)

Designation: **SF** Securing tight (the connection is difficult to loosen)

**Application:** Screw joints

### Fixing procedure

In general, it is sufficient to apply the synthetic on the screw thread.

If screws are screwed into socket threads, only wet the tap hole in order to let the air escape during screwing. Screws or nuts to be tightened with a specified torque are slightly oiled on their contact surface or housing section.

### Directions for fixing (B)

Designation: **BM** Fixing medium tight

Designation: **BF** Fixing tight

**Application:** Joint connections, sleeves, gear wheels, pulleys, bearings etc.

### Joining procedure

For joining connections, both joining parts are to be wetted. Wetting should completely cover the joining surfaces. In the case of sliding fits, the parts are to be encased by turning. No strength may be exerted to the connection until sturdiness is reached (for duration see table 1).

### Directions for Sealing (D)

Designation: **DR** Sealing of pipe connections

Designation: **DF** Sealing of plane surfaces

**Application:** Sealing of threads, screwings, joint connections and plane surfaces.

### Hardening time

Use	Securing		Fixing	Sealing		
Class	SM	SF	BF	DR	DF	DF
Product	Staloc 2S43	Staloc 2S62	Staloc 6S20	Staloc 5S18	Loctite 5900	Loctite 5910
Hand tightness after	15 - 30 min	15 - 30 min	5 - 10 min	0.5 - 48 h	30 min	30 min
Functional tightness after	1 h	1 h	1 h	0.5 h	2 h	2 h
Final tightness after	3 h	3 h	4 h	48 h	3 h	3 h
SMO part no.	9000059-1	9000017-1	9000019-1	9000297-0	9000298-1	9000510-5
Bottle volume	10 ml	50 ml	50 ml	315 ml	300 ml	50 ml

## 6 Variants engine propulsion

### 6.1 6 cylinder engines

#### 6.1.1 Bobtail - Version

##### Equipment

- with side mounted raw water pump
- or
- with side mounted raw water pump, power steering pump and front mounted auxiliary drive-PTO

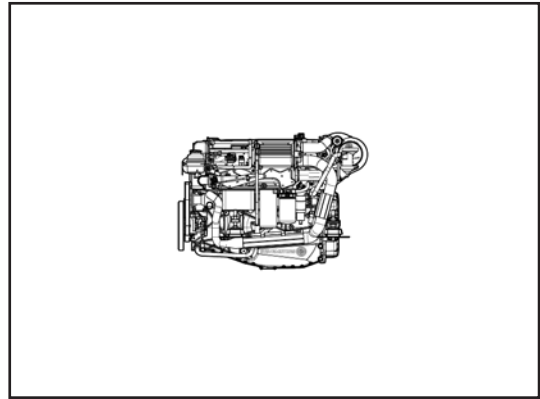

Fig. 70

#### 6.1.2 Down angle

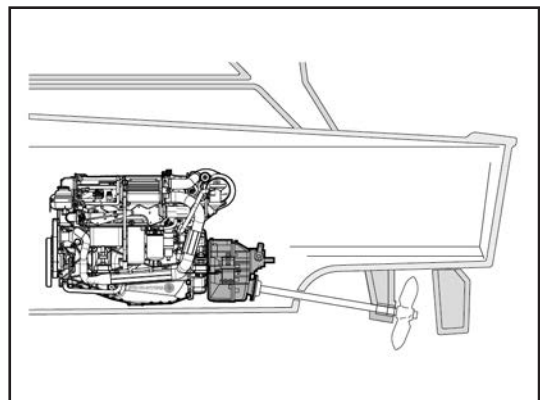

Fig. 71

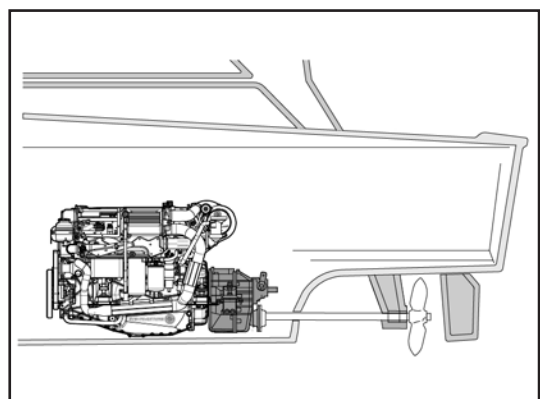

Fig. 72

### Transmission

$i = 2.5 V$ , shaft angle  $12^\circ$

$i = 2.0 V$ , shaft angle  $12^\circ$

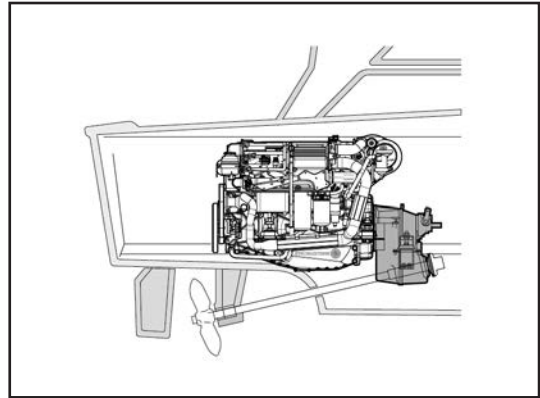

Fig. 73

### 6.1.3 Lifeboat engine

Equipment

Bobtail "B"

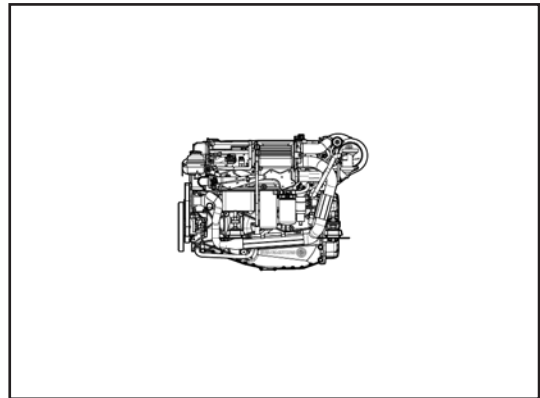

Fig. 74

Direct gearbox

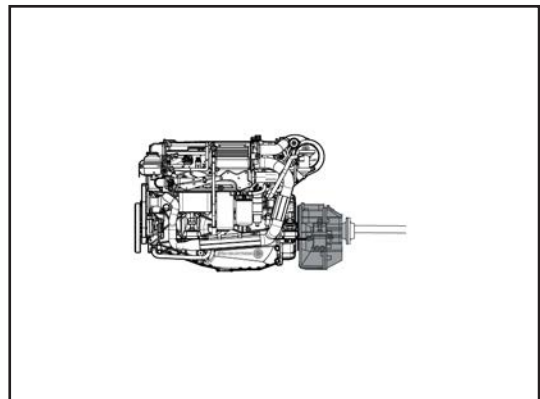

Fig. 75

A-down angle gear box

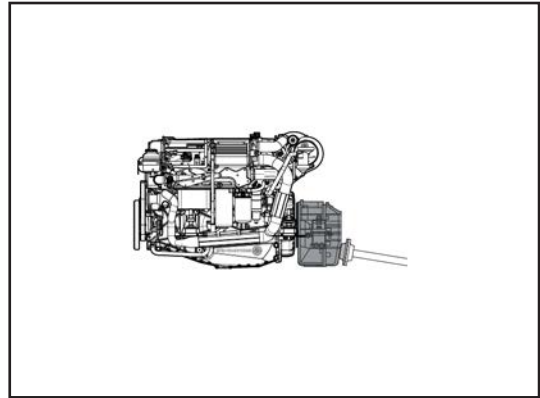

Fig. 76

Parallel offset gearbox

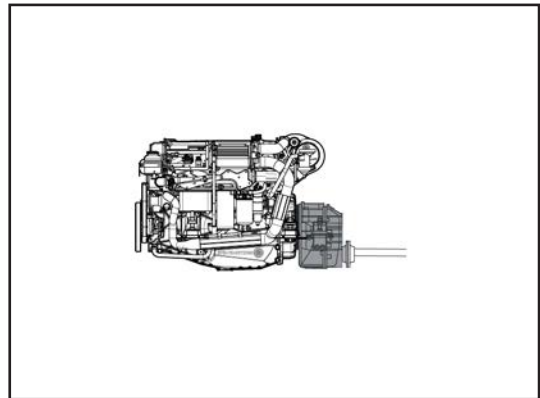

Fig. 77

#### 6.1.4 Jet drive

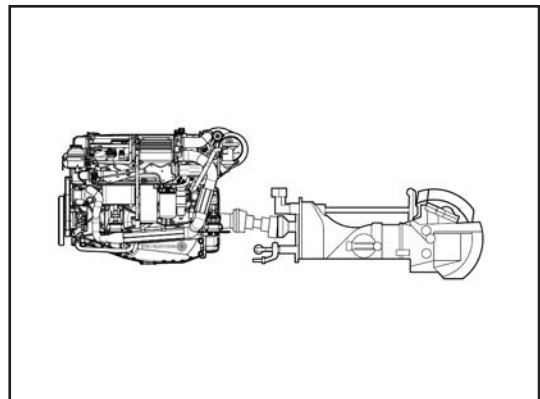

Fig. 78

TYPE

Alamarin

Hamilton

Castoldi

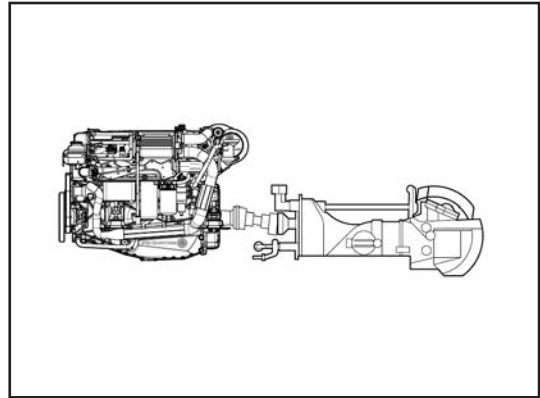

Fig. 79

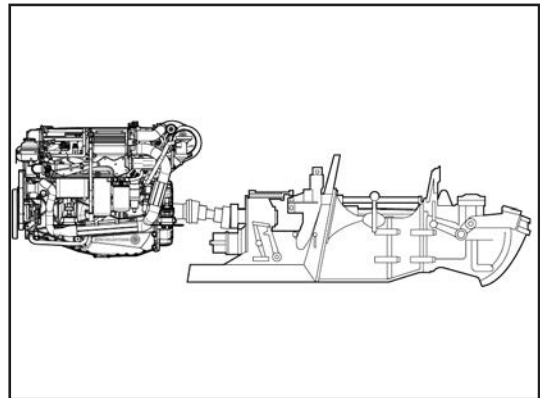

Fig. 80

### 6.1.6 Stern drive

TYPE

Mercury Bravo II & III

Volvo DP 290

Stern Power Drive

Volvo DP 290 ZF  
Hydraulic Pump

Volvo SX - Drive  
King Cobra Drive

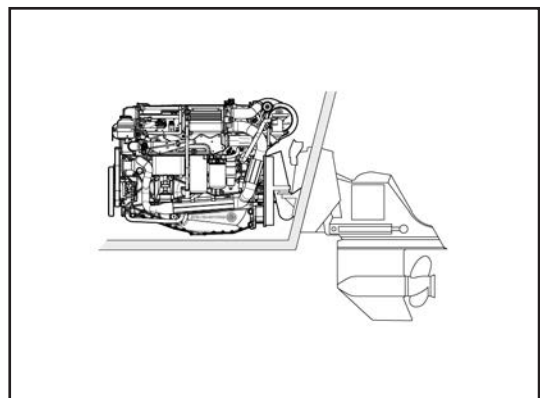

Fig. 81

## 6.2 4 cylinder engines

### 6.2.1 Bobtail - Version

#### Equipment

- with side mounted raw water pump
- or
- with side mounted raw water pump, power steering pump and front mounted auxiliary drive-PTO

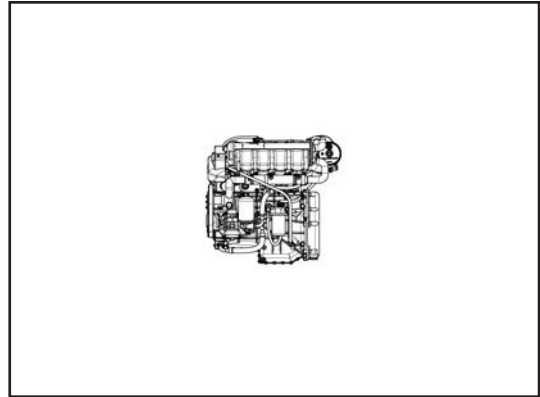

Fig. 82

### 6.2.2 Down angle

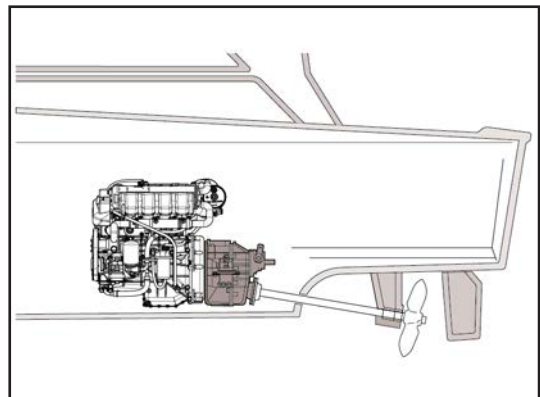

Fig. 83

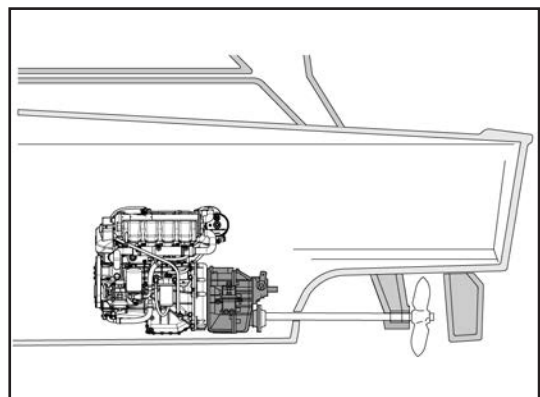

Fig. 84

### Transmission

$i = 2.5 V$ , shaft angle  $12^\circ$

$i = 2.0 V$ , shaft angle  $12^\circ$

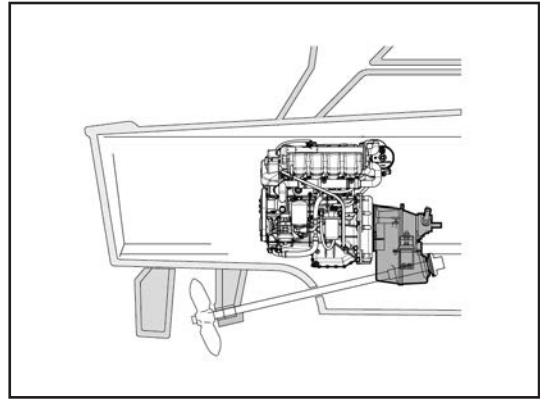

Fig. 85

### 6.2.3 Lifeboat engine

Equipment

Bobtail "B"

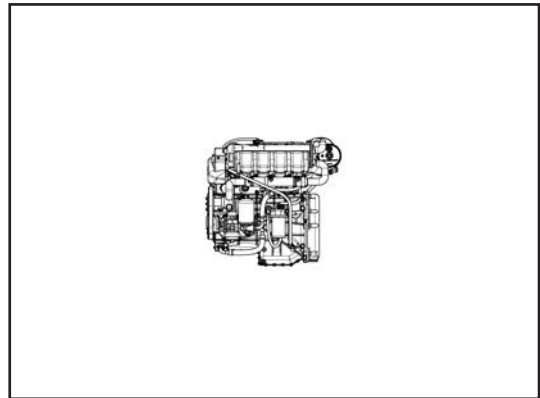

Fig. 86

Direct gearbox

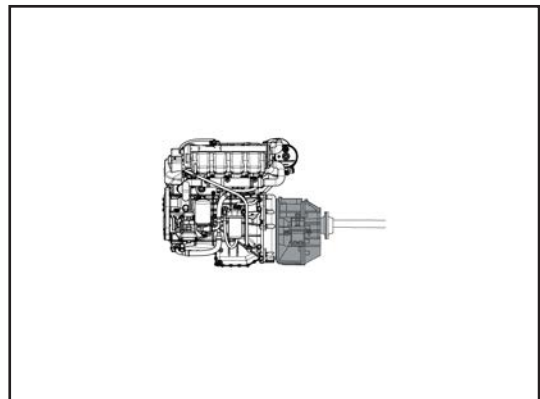

Fig. 87

A-down angle gear box

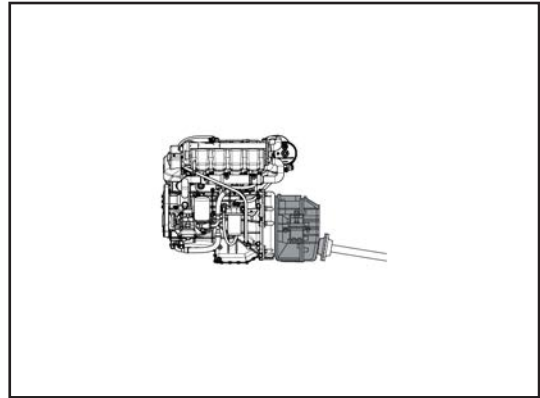

Fig. 88

Parallel offset gearbox

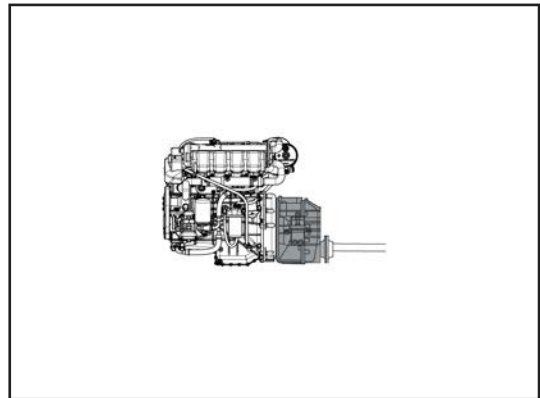

Fig. 89

#### 6.2.4 Jet drive

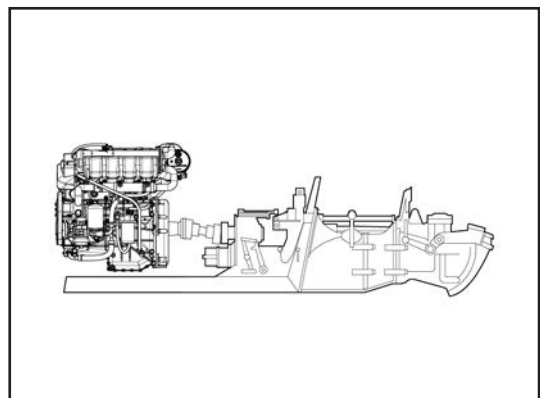

Fig. 90

## Variants Engine - Propulsion

---

TYPE

Alamarin

Hamilton

Castoldi

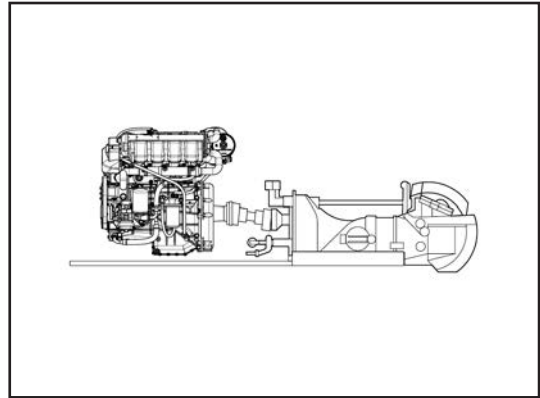

Fig. 91

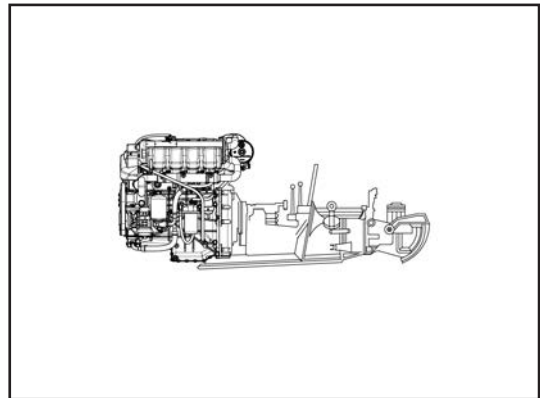

Fig. 92

### 6.2.5 Stern drive

TYPE

Mercury Bravo II & III

Volvo DP 290

Stern Power Drive

Volvo DP 290 ZF

Hydraulic Pump

Volvo SX - Drive

King Cobra Drive

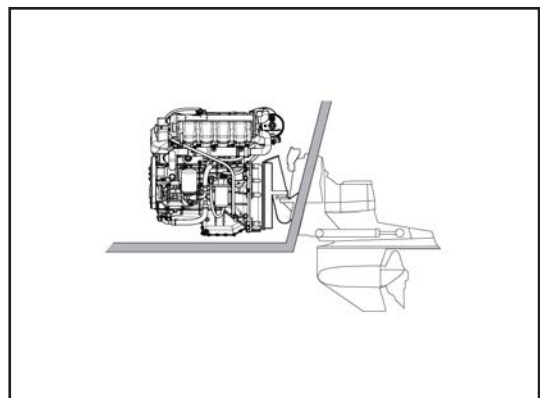

Fig. 93

### 6.3 Emission relevant components

Following parts are exhaust gas relevant components

The part numbers can be found in the respective spare parts catalogue.

- Cylinder block
- Camshaft
- Intercooler
- Turbocharger
- Piston
- Unit injector
- Exhaust manifold
- Fuel supply pump
- ECU
- Engine speed / timing sensor
- Coolant temperature sensor
- Intake pressure sensor
- Intake Manifold temperature sensor
- Fuel temperature sensor
- Fuel pressure sensor
- Closed breather system
- Hoses, clamps, fittings, tubing (whose failure affects exhaust emissions)



## 7 Engine installation

After pre-planning, assembly of the engine usually begins with the engine base. Then the stem bearings, if available, the step- or thrust bearing and the propeller shaft are mounted. After that, the fuel tanks, the water tanks with control device and the battery box are installed.

The engine is attached to the base and aligned in relation to the propeller shaft. Then the exhaust pipes, the air pipe to the engine, the aeration pipes and the sound-absorbing material for the engine compartment are mounted. Manoeuvring apparatus, instruments and electrical equipment are installed last.

After the final trial run, a precise check with final inspection is to be carried out. Test results are to be noted.

### 7.1 Foundation

The individual aggregates and parts of the marine propulsion unit must be aligned precisely to each other in order to guarantee a trouble-free operation. The distortion rigidity of the foundation should be to such an extent that ship distortions, due to motion of the sea or loading and unloading of the ship, are not transmitted to the propulsion unit. In addition, the foundation must absorb the propeller thrust of the thrust bearing and transmit it onto the hull.

The foundation's supporting surface for the propulsion unit should be approximately  $\frac{3}{8}$  - 13/16 " (10 - 20 mm) under the nominal size in order to permit, during assembly and alignment of the unit, the balancing of unevenness and differences by means of fitting pieces. All fitting pieces should be of the same material, e.g. steel or cast steel. Soft material, e.g. copper, must not be used for fitting pieces and shims.

For boats made of wood or synthetics, as well as for ships not built for a self-contained propulsion or where a considerably stronger unit should be installed, it may be useful to attach a subframe for reinforcement of the foundation.

### 7.2 Power transmission

#### 7.2.1 Coupling

For power transmission from the engine to the gear we recommend a turn-elastic coupling. In all other cases of engine and gear suspension, a turn and radial elastic or an articulated coupling with torsion spring plate is required between engine and gear. Coupling size depends on the maximum engine torque to be transmitted, the torque peaks due to the degree of irregularity of the engine, and the alternating moments of torsional vibration at critical speeds of the boat. Based on a torsional-vibration computation, it must be checked whether the chosen coupling as well as dimensioning and arrangement of the unit could lead to undue torsional vibrations causing severe damages.

For couplings using rubber as spring elements and for power transmission, it is to be considered that the transferable alternating moment of oscillation decreases very fast with increasing temperature of the rubber. Based on the information of a known manufacturer of elastic couplings, the temperature factor at 60 °C is 1, and at 80 °C 0.5 only. Therefore an effective aeration of the coupling is useful since the rubber expands or contracts with ambient temperature.

For assembly of the clutch and alignment of the coupling flanges, the manufacturer's instructions are to be considered.

When assembling a coupling, or a connecting shaft between engine and gear, or when flanging a gear, the end clearance of the engine's crankshaft must not be affected. V-belts, gear couplings or similar connecting links thus should permit engagement easily. Also when flanging a gear onto the engine, make sure that after tightening the fastening screws, no axial load or tension is transmitted onto the crankshaft. It is, therefore, necessary to check the end clearance of the crankshaft journal before and after assembly. During both checks, the clearance must be equal. The crankshaft must not spring back after pressing it against the front and rear collar of the lapped bearing.

On boats destined for frequent reversing and manoeuvring, e.g. service boats, the couplings are heavily stressed by start-up impacts and acceleration. For this reason, a larger coupling should be chosen. In addition, it should be considered not to drive too long at the critical speed range.

If a disconnectable coupling is used, the admissible axial load of the crankshaft must not be exceeded.

### 7.2.2 Universal joint shafts

Principles:

A universal joint produces a more or less strong irregularity on the driving axle, depending on the diffraction angle. This irregularity is compensated by providing a second universal joint, under the following conditions:

- The two forks of the intermediate part must be coplanar.
- The diffraction angle of the second joint must be of the same size as that of the first one; both joints must be coplanar.

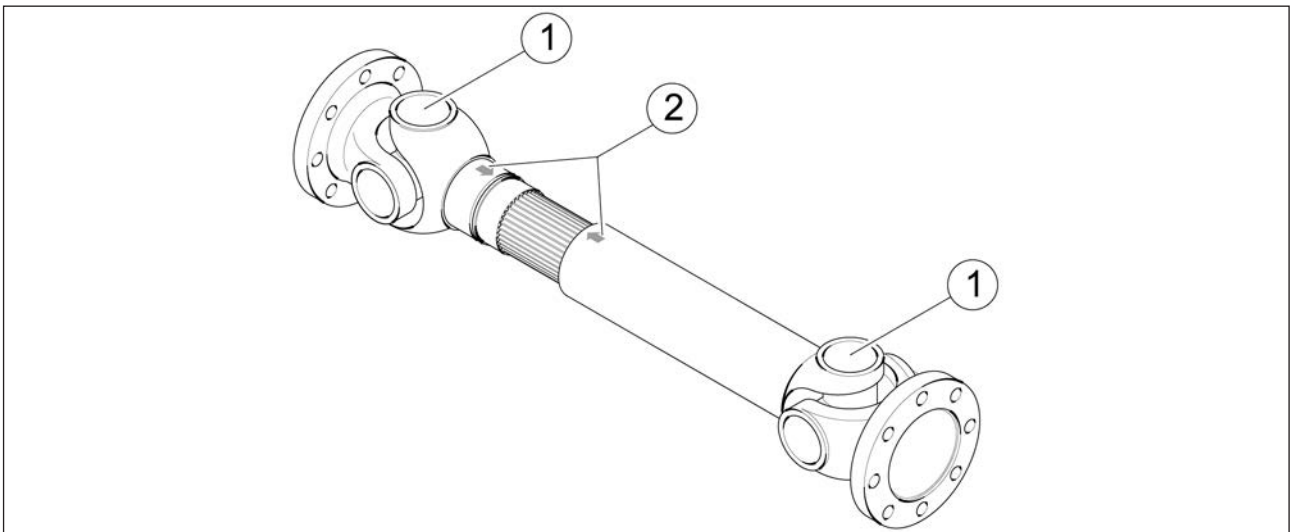

Fig. 94

Pos.	Description	Pos.	Description
1	Forks of intermediate shaft	2	Marking

The figure shows how the two forks of the intermediate shaft should be positioned to each other (according to 1. - coplanar). The splined shaft ends mostly show index arrows which should be opposite when connecting the shaft.

The following figure shows the Z- layout of a universal-joint shaft.

The two angles  $\beta_1$  and  $\beta_2$  must be equal. This means that with Z-design the contact faces of the shaft ends for drive and drift must be parallel to each other.

#### **i** Information

**Important:**

diffraction angle  $\beta$  min = 1 °,  $\beta$  max = 6 °

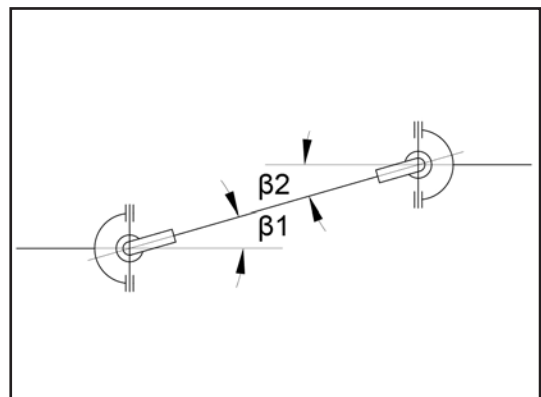

Fig. 95

## Engine Installation

---

Slight deviations from these requirements are admissible under certain conditions; to what extent depends on the application, the speed, the diffraction angle etc.

Depending on the diffraction angle of the two universal joints of a shaft, the intermediate shaft will be more or less accelerated or retarded with every rotation. This causes a stimulation of oscillation which is to be considered for the location of the universal-joint shaft between engine and gear. Overhanging mass on the shaft end at the flywheel side, such as e.g. couplings, may be critical.

Considering the additionally occurring bending moment which depends on the initiated torque, the length of individual universal-joint shafts cannot be chosen at random. If necessary, several universal-joints shafts are to be arranged.

### 7.2.3 Additional cooling circuit on engine

(e.g. transmission oil cooling)

For an additional cooling circuit to be fitted, the engine's tandem/triple cooler specifications must be kept.

## 7.3 Engine base

The engine base should be of a very rigid design. Its suspension is to be distributed on the maximum surface over the ship bottom. The engine base should be strong enough to absorb with free play the compressive- and shearing forces of the propeller. Strains through heavy sea and dynamic load are also to be considered.

### 7.3.1 Engine base on synthetic boats

On synthetic boats, the engine base may be made of flat irons (see figure on the right) casted in the boat. The base **(3)** should be constructed as a box, and filled with damp-proof material **(4)**.

The flat irons **(1)** should be long enough to distribute the load of the engine over a surface as large as possible. To facilitate screwing of the engine mounts, nuts **(2)** can also be cast.

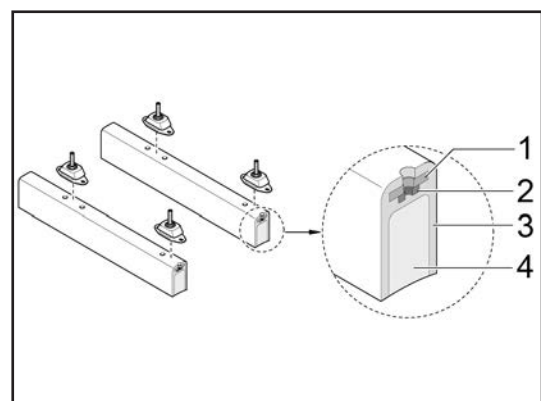

Fig. 96

## 7.4 Space for maintenance

The engine compartment is to be designed in such a way that maintenance work will not be impaired by bottom plates or other equipment. Compare these requirements to the maintenance chart in the operating manual. Also take care that there is enough space for lifting and lowering the engine.

Before beginning the assembly, make sure that scale drawings for the engine and its equipment are available (see appendix). All necessary dimensions for assembly follow from the scale drawings, e.g. the distance from the crankshaft centre to the engine bearers (reversing gear bearers) and to the centre line of the propeller shaft.

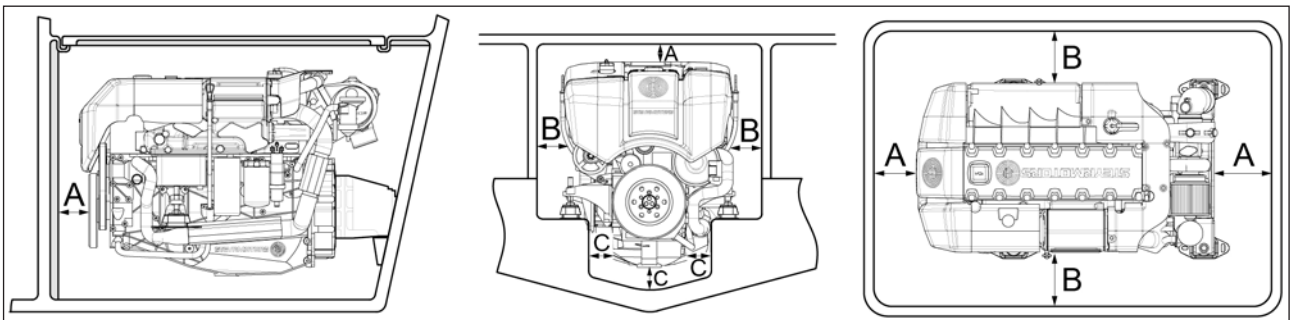

Fig. 97

A	B	C
min. 200 mm	min. 150 mm	min. 20 mm
min. 7.87 "	min. 5.91 "	min. 0.79 "

**Important:** Keep sufficient distance between base frame, oil pan and starter motor (<math>< \frac{3}{4} \text{ " / } < 20 \text{ mm}</math>).

### 7.5 Engine inclination

Max. permissible engine inclination (backwards in direction of flywheel) corresponds to angle A, see table.

The engine must not be inclined downward in direction of the heat exchanger, since such an installation could affect the cooling due to remaining air pockets.

When installing the engine with the flywheel side in direction of the bow, the inclination in direction of the flywheel should be at least 3 °.

Such an installation with inverted engine occurs with a miter gear.

During course, **A** may be up to 3 ° larger and **B** up to 3 ° smaller (the stern is lower).

Maximum engine inclination for assembly:

	<b>SE-Series max. inclination in °</b>
A	10 °
B	5 °
C	5 °
D	5 °

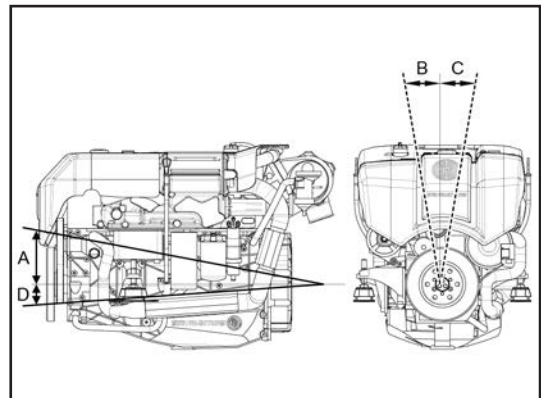

Fig. 98

## 7.6 Lifting eyes

### 6 cylinder engine

Pos.	Description
1	Lifting eyes Eyebolt can be removed after installing the engine.

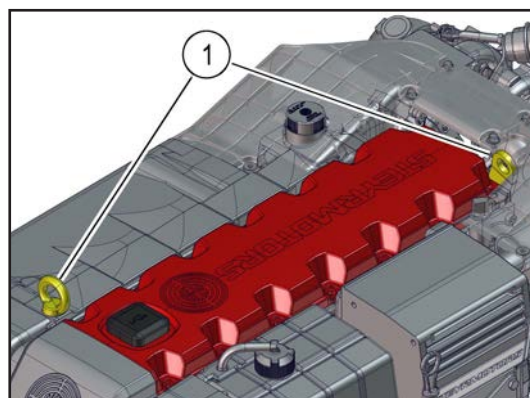

Fig. 99

### 4 cylinder engine

Pos.	Description
1	Lifting eyes

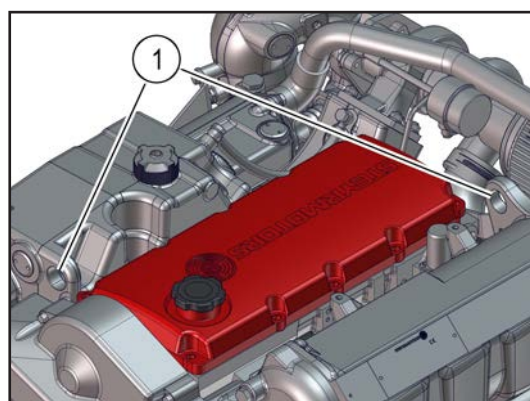

Fig. 100

### **NOTICE**

Never place the engine directly onto the floor. The oil pan and other parts could be damaged. Jack up the engine on the engine bearers so that its lower part is trailing, or keep the engine in the transport box until it is lifted into the boat.

Do not lift the engine from any single lifting point, damage to the engine or personnel injury could occur. When having to tilt the engines for installation, use an adjustable load leveller to aid in installation.

## 7.7 Checking of engine base

When preparing the engine base, make sure that the upper contact surfaces of the bearers are parallel to the centre line of the propeller shafts and are not swung. For assistance during assembly and checking of the engine base, a short traversing slide with the same diameter as the propeller shaft may be used stern-side; see figure below. Through a bore (1/12" / 2 mm diameter) in the slide a 1/12" (2 mm) copper wire is strained to a holder. Then adjust the holder in such a way that the wire is in the centre of the front end of the propeller shaft sleeve.

Then measure the base bearers and check their correct height and that they are not swung.

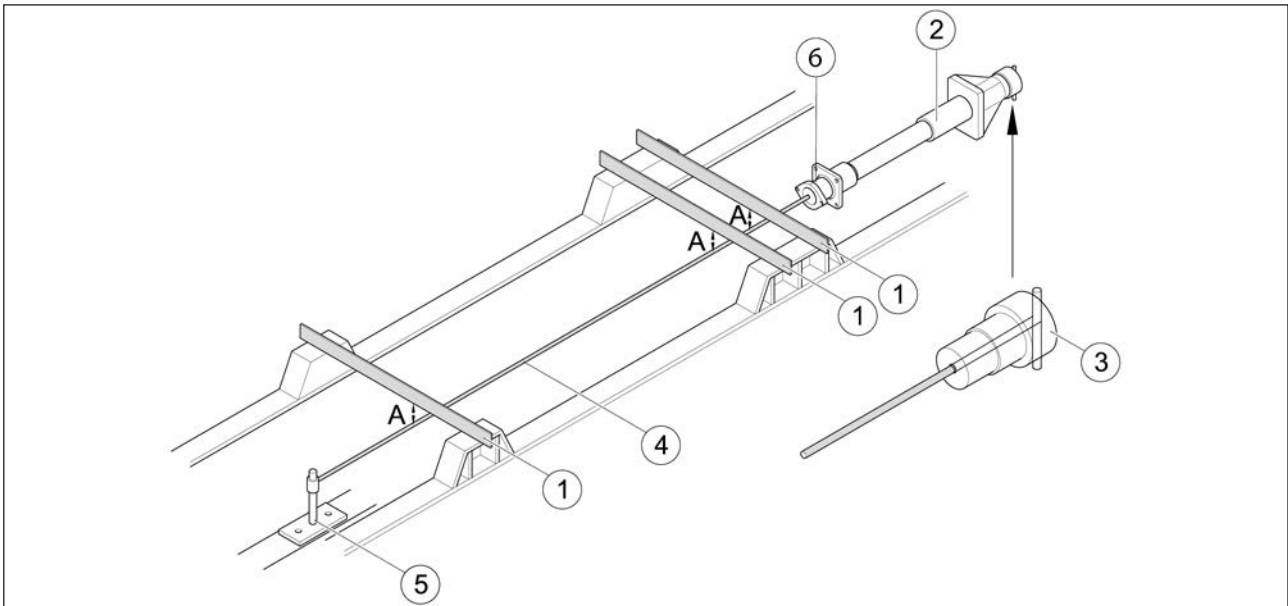

Fig. 101

Pos.	Description	Pos.	Description
1	Steel rulers	2	Stem tube
3	Traversing slide (dimensions correspond to respective shaft size)	4	Copper wire
5	Holder with chuck	6	Distance engine base surface - propeller shaft centre (depending on type of engine and marine gear box, refer to chapter 6 Variants engine propulsion, engine model and gear box configuration) For drawing dimensions, see installation drawings on <a href="https://www.steyr-motors.com">https://www.steyr-motors.com</a>

## 7.8 Propeller shaft flange

At delivery, the flange to the reversing gear is rough-drilled only. The bores are to be made with utmost accuracy and have to correspond to the guiding edge on the flange.

Max. admissible radial stop: 0.05 mm

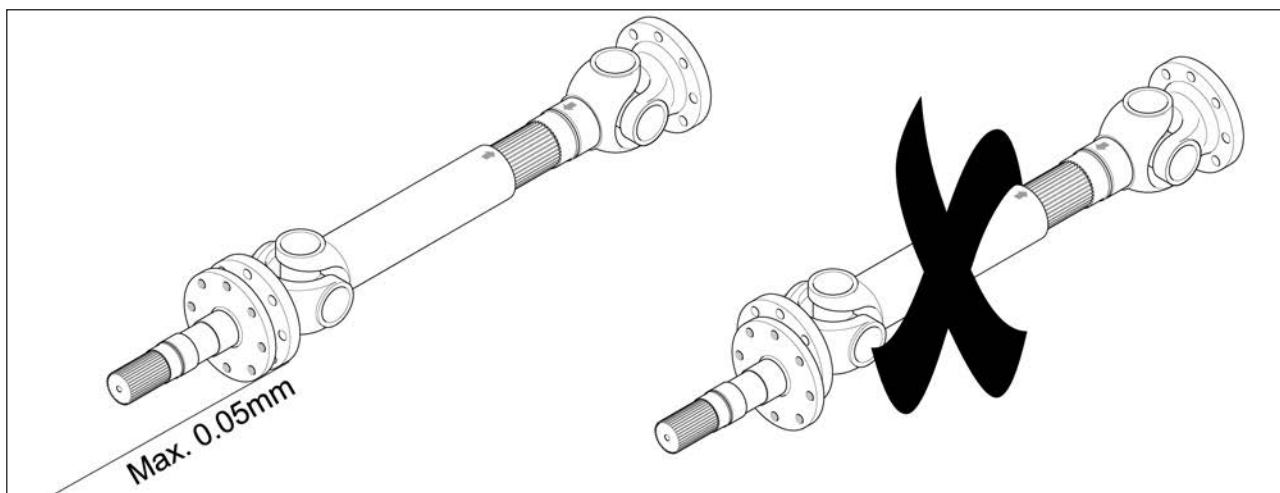

Fig. 102

In many cases it is recommended to bore the coupling flange to the reversing gear with the same conicity as for the propeller. Thus the shaft will be equal on both ends and can, therefore, be turned in case of being worn out in the stem bearing.

### 7.9 Engine mounts

The flexible engine mounts provide proper insulation between engine and base frame, thus reducing the noise conveyed to the hull. This engine suspension may also absorb the thrust and shearing forces of the propeller.

Pos.	Description
A	Bore dimension bearing flange
B	Position of adjustment nut (~ 5 mm)
C	Adjustment space ( $\pm 5$ mm)
D	Spacer plate (if required)

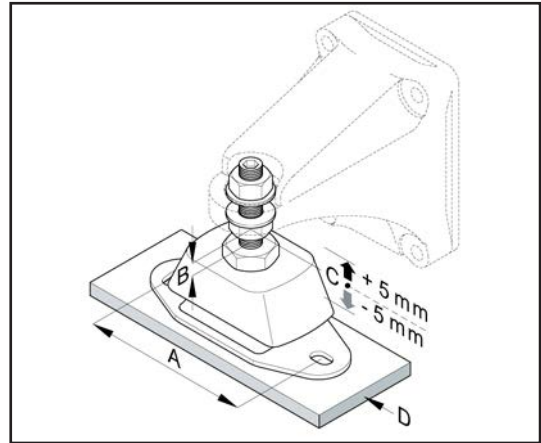

Fig. 103

Install the engine mounts directly onto the member of the base frame, see chapter engine base [Fig. 96](#).

For an assembly with flexible engine mounts, the overall height of the engine mounts is to be considered to achieve the proper installation height of the engine. Height adjustment is recommended to achieve accurate alignment of the suspended unit.

When fitting mounts with height adjusters, care must be taken to ensure that excessive bending forces are not imposed on the center spindle (screw). Mountings fitted with height adjusters are designed to allow a variation of  $\pm 5$  mm on nominal mean height (see figure 5 mm distance between adjustment nuts). Any larger variations need to be accommodated by fitting shims or packers under the mounting base. Vertical and horizontal alignment should then be effected using the height adjusters and slotted holes in the mounting base. Recheck alignment after fixings are tightened to the specified torque values (nut center spindle screw 110 - 120 Nm).

### 7.9.1 Adjustment of engine on flexible engine mounts

The settings of the left and right height adjusters should be equal. Between the front and rear of the engine, a difference in adjustment is admissible and often unavoidable. Before beginning the alignment, the engine should rest on the mounts for about 48 hours.

Proper setting of the engine mounts can be done as follows:

Roughly align the engine with the propeller shaft on the mounts by means of adjusting nuts, without connecting the propeller shaft to the flange on the reversing gear.

#### Lateral adjustment

1. Lift the engine at the front to release both front supports from the lower nuts of the mounts.
2. Gradually lower the engine and adjust the nuts so that each engine support sits simultaneously onto the adjustment nuts.
3. Use the same procedure for the rear of the engine.

The engine foundation must be rigid enough to support the concentrated load. Lateral balance should be attained before attempting a longitudinal adjustment.

#### Longitudinal adjustment

1. Level the engine by adjusting either the front or rear adjustment nuts.
2. Apply the exact same number of turns for the left and right adjustment nuts.
3. Repeat the procedure for the opposing side (front or rear) if necessary.

In the longitudinal direction, the vibration dampers are to be mounted free of tension.

Engine mounts being mounted with initial stress may transmit vibrations and sound into the hull.

The oblong holes in the vibration damper feet permit a lateral correction of the adjustment. When the boat is in the water, the alignment is to be checked once again.

### 7.10 Elastic shaft coupling

For engines with elastic suspension and a rigid stem bushing, an elastic shaft coupling is always to be mounted.

Even for a rigid engine suspension, an elastic propeller shaft coupling should be mounted if there is any risk that the engine may change its position with regard to the propeller shaft, e.g. with different load of the boat.

Never use the elastic shaft coupling together with the elastically supported stem bushing. This may result in heavy vibrations. Elastic engine suspension and elastically supported shaft bushing may, however, be used without elastic coupling.

Engines provided for operation under heavy conditions, e.g. way through ice, are always to be equipped with elastic propeller shaft coupling. A special thrust bearing for the propeller shaft is also to be mounted. The elastic coupling should be situated between reversing gear and thrust bearing, to avoid tensions between the parts.

### 7.11 Step bearing

If the distance between the supports (A in *Fig. 105* and *Fig. 106*) exceeds 6 ½ ft (2 m), a step bearing is to be mounted. The correct distance between the step bearing and the engine is of utmost importance, which requires a computation of vibrations.

#### Examples:

Elastic engine suspension, elastic stem tube and bearing at 8 ° for reversing gear.

1. Elastic engine suspension
2. Gland in rubber suspension
3. Grease gun

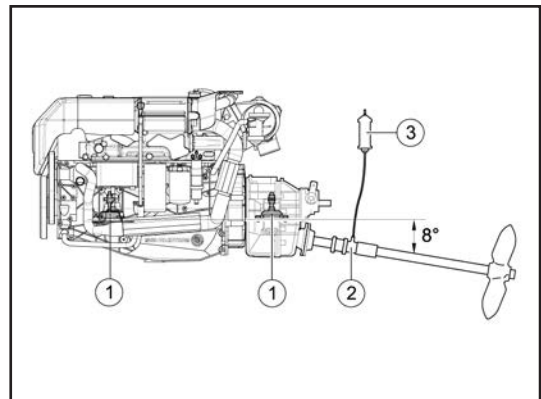

Fig. 104

Engine with elastic suspension and fixed stem bearing

1. Elastic engine suspension
2. Elastic shaft coupling
3. Butt-supported stem bearing

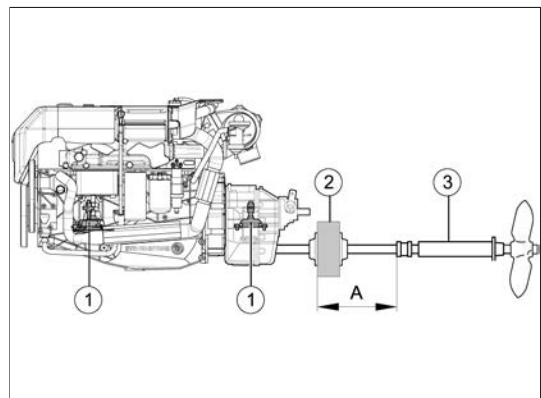

Fig. 105

#### **NOTICE**

The stem bearing must not be elastic.

A max. distance between supports  
6 ½ ft (2 m)

Engine with elastic suspension and elastically supported stem bearing

1. Elastic engine suspension
2. Elastically supported stem bearing

#### **NOTICE**

The shaft coupling must not be elastic.

A max. distance between supports  
6 ½ ft (2 m)

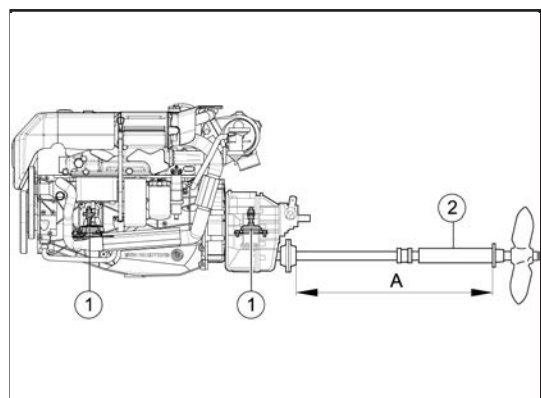

Fig. 106

## 7.12 Adjustment of engine drive unit

As soon as the base frame has been finished, the propeller shaft mounted and the other preparation works done, the engine and the reversing gear can be mounted.

For engines with double reversing gears, the reversing gear is to be mounted first and exactly aligned to the propeller shaft. Then the couplings are mounted, and the engines are aligned towards the reversing gear.

First adjustment of the engine on the boat can be done either on land or on the seas. Before final adjustment, the boat should, however, be on the seas for some days so that the body can take its final shape.

When mounting a marine reversing gear, it is recommended to check the parallelism of the flanges by means of a dial gauge.

In this case, the propeller shaft is to be moved sternwards for approximately  $\frac{3}{8}$ " (10 mm) and be well supported so that the clearance in the stem tube is uniformly distributed (exactly center the shaft). Rotate the reversing gear shaft and measure at first the radial dimensional deviation. Correct the position of the reversing gear. Then check the axial off-size by a hinge dial gauge on the contact surfaces of the flange. In both cases, the maximum possible off-size is 0.1 mm.

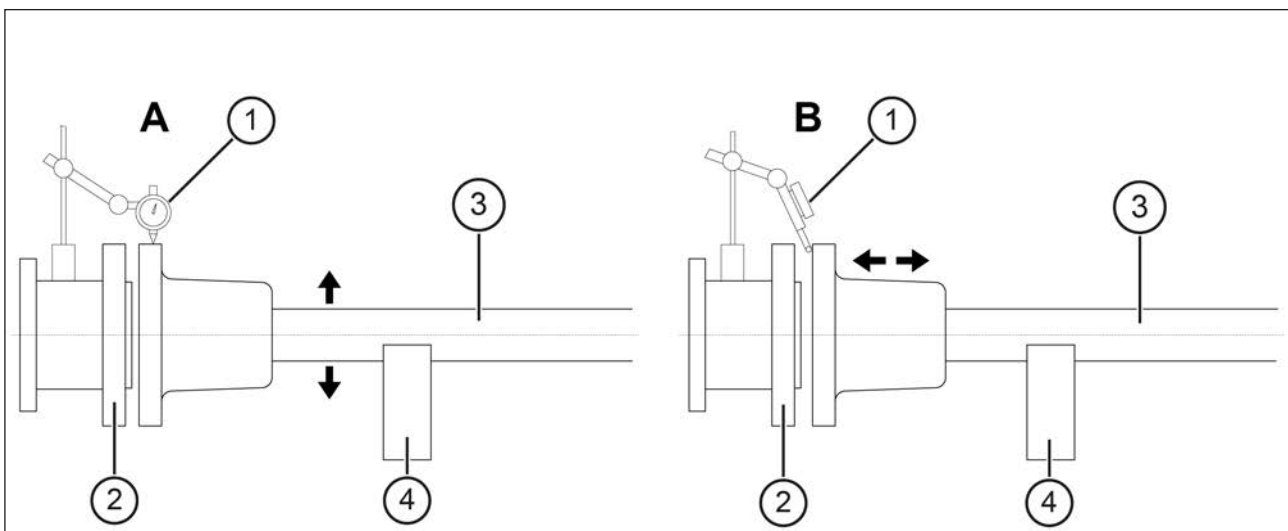

Fig. 107

Pos.	Description
<b>A</b>	Checking of radial off-size
1	Dial gauge
2	Flange on reversing gear
3	Propeller shaft
4	Support of propeller shaft

Pos.	Description
<b>B</b>	Checking of axial off-size (hinge dial gauge)
1	Dial gauge
2	Flange on reversing gear
3	Propeller shaft
4	Support of propeller shaft

## Engine Installation

After having finished the adjustment, prepare supporting disks to fit between the engine-reversing gear bearers and the engine rests. Measure the distances and prepare steel disks to be ground to the dimensions measured.

Make all bores for the bearers, and screw on the engine and the reversing gear. Take care that all setscrews for the high position are unscrewed so that the bearers do not rest on the screws but on the supporting disks. After alignment, remove the setscrews for high position.

After launching the boat, check the adjustment once again. The boat with filled tanks and the required equipment should have been on the seas for some days. Ship bodies are elastic and do not have the same shape when they are propped up.

In case of a necessary readjustment, distance plates can be mounted under the bearers. After start-up of the boat, verify at regular intervals that the adjustment of the machine unit has not changed due to deformations of the body.

A bad alignment of engine and propeller shaft may cause a lot of disturbances and operating troubles. Such troubles may result in vibrations in the hull, in the reversing gear, and in premature wear of the propeller shaft bearings, the shaft and the stem tube supports.

### 7.13 Twin installation

When mounting engines with one propeller each, choose the reversing gears in such a way that the starboard propeller rotates clockwise and the port side propeller counterclockwise, seen in the direction of the bow.

Centre distance of shafts A (min. dimension) approx.: > 31" (> 787 mm)

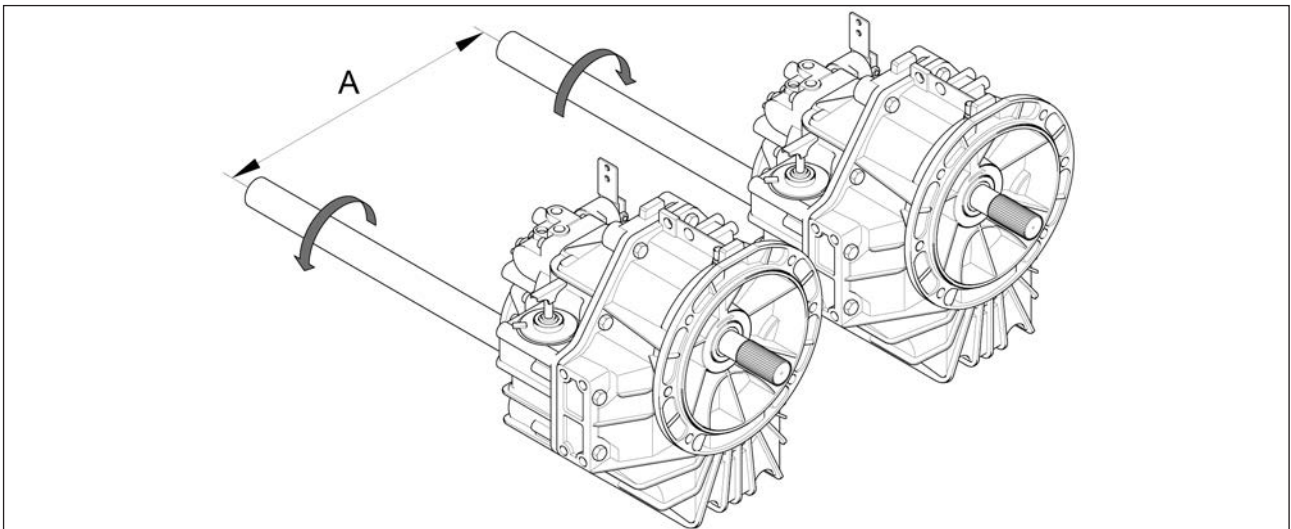

Fig. 108

## 7.14 Shaft and stem tube

To choose the right engine, reversing gear, and propeller components with regard to the respective load ratio, follow the power and speed recommendations of the engine. The recommendations for various engines are found in the product information "marine engines". Consider a sufficient distance between propeller, hull, keel, stem tube and oar. To permit a dismantling of the reversing gear or the coupling, a sternward displacement of the propeller shaft of at least 8" (200 mm) should be possible. Also take care that no transept bulkheads interfere with dismantling. Between propeller and stem bearing a minimum distance of 1" (25 mm) is to be kept in order to prevent the propeller from bucking against the stem bearing.

Before mounting the shaft, its straightness is to be inspected. Check by means of a dial gauge that the shaft flanges do not twist. The maximum admissible axial fault is 0.1 mm.

Before launching the boat, make sure that a propeller with correct pitch and diameter has been mounted. Also check that the propeller shows the correct thread (R or L) for the provided sense of rotation. The exact alignment of the whole drive unit on the foundation is a condition for trouble-free operation. On principle, assembly and alignment is done in order from driving shaft to engine. Flange connections and couplings (even elastic ones) must be released when aligning the parts connected. For elastic couplings, follow the manufacturer's instructions.

For alignment of the parts to be mounted, a dial gauge with suitable holder, and eventually a thickness gauge, will be necessary. Alignment always requires two checks:

- Vanishing check (contact accuracy) and
- Angularity check (no bends).

With two dial gauges, both checks can be done simultaneously.

For each check, the part at which the dial gauge is fixed is to be moved for at least one turn. An exact alignment of the part to be mounted mostly requires several checks. Because of that, it is advisable to fix the dial gauge on the part which can be turned more easily.

### 7.15 Propeller

Too less attention is paid to the propeller and in particular to its efficiency even though it is responsible for transformation of engine energy into movement. Sizing and selection of the propeller have a major impact in determining drive quality and fuel consumption.

Voluminous books have been written about right sizing and computation of a propeller. For this reason, the following information shall serve for better understanding of the complexity and impart basic knowledge.

Of all driving possibilities developed so far, the propeller shows the best efficiency. Sizing of the propeller is determined by the boat type, the engine power and speed.

#### 7.15.1 Dimensions

A propeller is designated by diameter, pitch, number of blades, blade surface, sense of rotation and hole in the hub.

Diameter of the propeller is determined by:

- Engine power in horsepower or kilowatt-hours
- Propeller speed (number of revolutions of engine divided through reduction of gear)
- Speed of the boat.

It is a wrong assumption that the propeller determines the speed, but it is the combination of engine power with adapted hull and matching propeller.

The propeller diameter can be approximately computed based on the diagram enclosed, but this is only for "water displacers". Before using the diagram, the max. speed of the ship is to be computed. Only use this diagram for an approximate computing of the diameter, e.g. for determining the height of the propeller frame. Computing of the correct diameter and of the pitch is to be done by a specialist.

### 7.15.2 Propeller pitch

The pitch is the theoretical distance the boat runs at one rotation of the propeller, which is being determined by the speed of the boat and assuming no propeller slip. Every propeller rotating in water will have a slip. Thus the advance of the boat will be approx. 60 to 75 % per rotation of the propeller.

A propeller, the pitch of which is not exactly adapted to the speed of the boat, will always show a lower efficiency. To reduce the diameter and then increase the pitch for the same size, which sometimes is required when the actual diameter cannot be housed, will thus reduce the efficiency.

### 7.15.3 Blade surface

Correct determination of the blade surface is also to be done by specialists. It depends on the speed and the type of boat, and is always indicated in relation  $F_a / F$ ;  $F$  being the total area of the propeller circle and  $F_a$  the surface of all blades or wings together. Every propeller type has a fixed  $F_a/F$  relation.

### 7.15.4 Sense of rotation

To determine the sense of rotation of a propeller, always stand behind the boat and look forward. If the propeller rotates counterclockwise, then it is a left-hand propeller, and if rotates clockwise then it is a right-hand propeller.

It is the engine which always determines the sense of rotation of the propeller, which can, however, be reversed by using a reversing gear.

### 7.15.5 Number of blades

The number of blades is determined by the speed of the boat, the number of rotations of the propeller, and the type of boat (dumb barge, fisher boat, glider, ...), and is first of all a matter of experience. In general, for standard boats up to a length of approx. 70 ft (20 m), with an engine speed of more than 800 rpm., propellers with more than three blades are being used. If much speed at low revolutions is required, in particular on larger boats, even propellers with more than three blades are used. This should also be determined by specialists. For the same boat and the same engine the diameter of a four-blade propeller may be by 10 % less than that of a three-blade propeller. On sailing boats often a two-blade propeller is used which lessens the resistance and reduces the efficiency for an aliquot part only.

### 7.15.6 Axle hub

To permit a proper and centric mounting of the propeller on the propeller shaft, the propeller should be provided with a well fitting conical hub and a spline. Mostly the cone's pitch will be 1:10. In the United States and in England one may also find cones with 1:12 and 1:16.

Conicity of a hub is told by the difference between the largest and the smallest diameter, divided through the hub length.

$$\text{Cone} = \frac{D - d}{L}$$

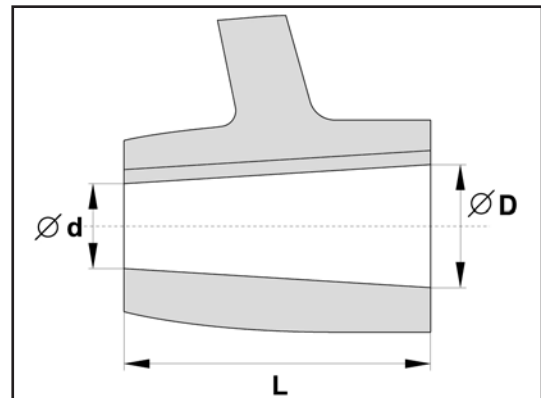

Fig. 109

### 7.15.7 Adjustment of propeller pitch

In case of a too high or too low propeller pitch, a specialist may adjust the blades within a certain limit, which, however, should be avoided as far as possible. It is a difficult task and, moreover, it is almost impossible to modify the pitch close to the hub, and to obtain a uniform pitch in every diameter of the propeller chosen at random. On principle, the pitch never should be modified for more than some cm, and this only in case of no other solution.

### 7.15.8 Space between propeller and boat

The maximum propeller diameter results from the shape of the hull. The figure shows a displacer but even for a glider the conditions are similar. The most important size **A**, the space between propeller and hull, should be at least 2 " (50 mm) resp. 10 % of the propeller diameter (noise, malicious vibrations). Size **B** should be approx. 30 % of size **D**. **C** = ¾ " (20 mm) more than the propeller hub length in order to avoid a dismantling of the oar in case of a propeller change.

**X** = space propeller - stem bearing 1 " (25 mm)

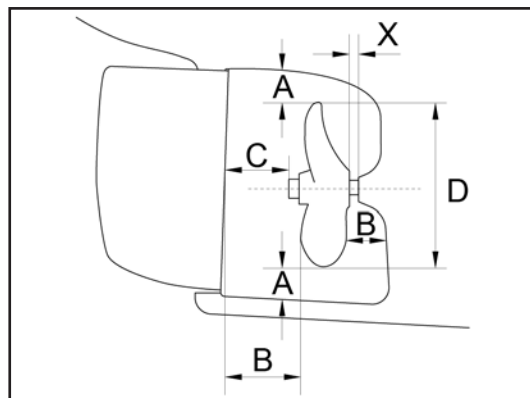

Fig. 110

### 7.15.9 Sediments

When removing sediments from the hull, pay special attention to the propeller. Salt water in particular, but also sediments and vegetation cause additional resistance, and thus a smaller efficiency resulting in a lower speed.

In general, lower propeller speeds bring about higher efficiency and less vibrations compared to high speeds.

### 7.15.10 Choice of propeller

There are a couple of coarse rules:

In general, for a "water displacer" a 3-blade propeller with  $Fa/F$  of approx. 0.51 will be sufficient. More or larger blades do not make sense.

For semi-glider we generally recommend 3- or 4-blade propellers with  $Fa/F$  of 0.54 to 0.74. For gliding boats, 4-blade propellers with  $Fa/F$  of 0.54 to 0.74 may be considered.

Most propellers are made of bronze, but propellers made of metal or aluminium are also available.

### Various propellers with examples of application:

3-blade high-speed propeller

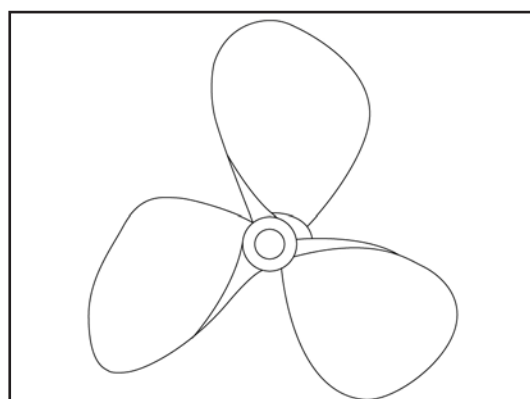

Fig. 111

3-blade propeller for commercial use

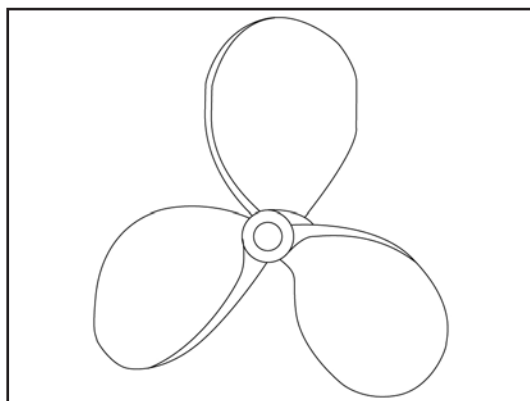

Fig. 112

3-blade propeller to be applied in regions with strong alga and algae vegetation

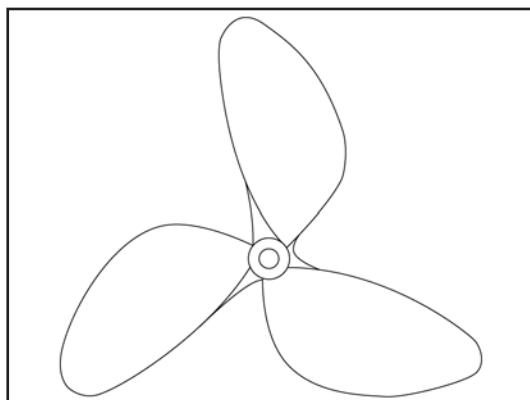

Fig. 113

2-blade propeller to be applied on sailing boats

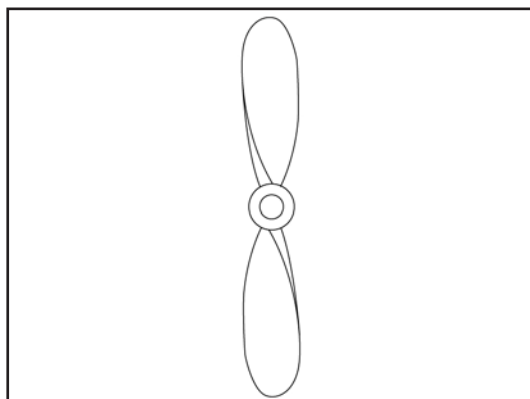

Fig. 114

2-blade folding propeller to be applied on sailing boats

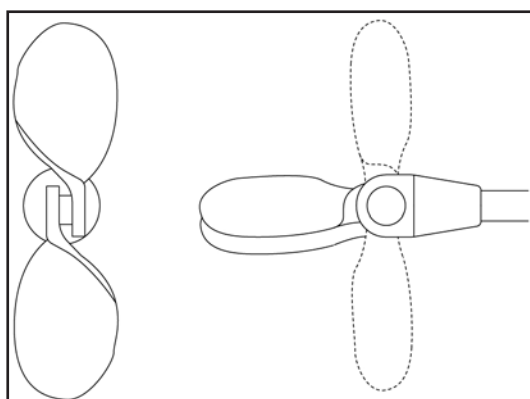

Fig. 115

### 7.15.11 Cavitation

Propellers which have not been computed correctly (e.g. a propeller with a too large pitch) may cause cavitation (formation of steam bubbles). Cavitation may damage the propeller and occurs as the reduction of pressure on the suction side of the propeller is too great.

### 7.16 Propeller - thrust bearing resp. step bearing

All reversing gears covered by our product offer are provided with attached axial bearings to account for the traction and shearing forces of the propeller shafts. In the case of normal load conditions, no other thrust bearings are required. For very strong loads, e.g. industrial operation on ice, separate thrust bearings may be required. In such cases, an elastic coupling between reversing gear and thrust bearing is always to be installed in order to avoid axial tensions between the two thrust bearings.

With a shaft length exceeding the standard size, a separate step bearing is to be installed. The step bearing cannot take axial forces.

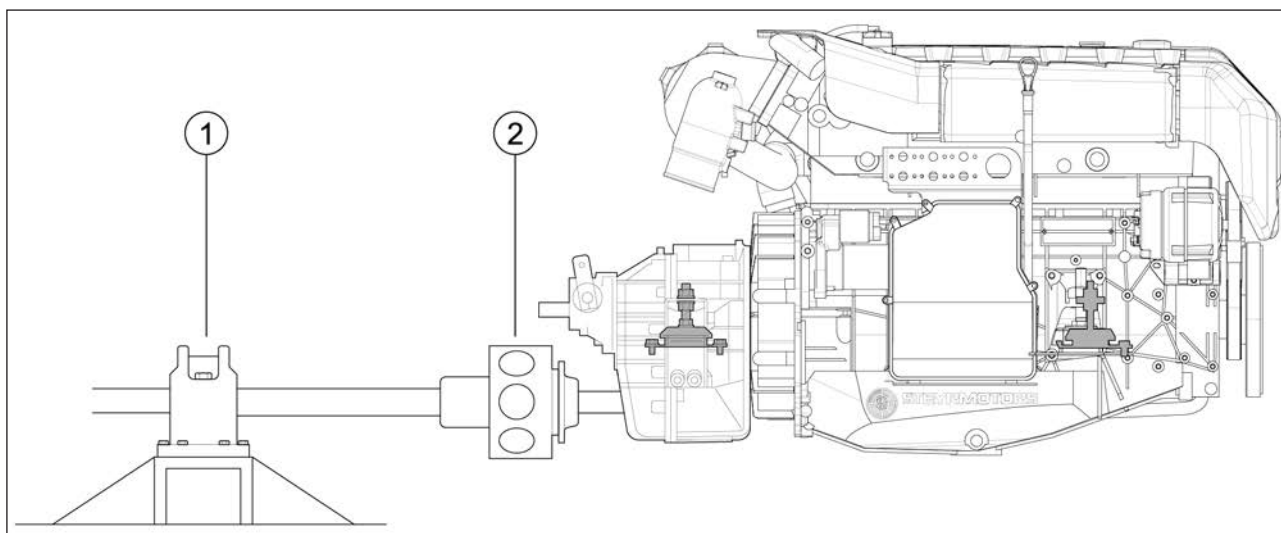

Fig. 116

Pos.	Description	Pos.	Description
1	Thrust bearing	2	Elastic coupling



## 8 Cooling system

### 8.1 General

**Steyr Motors** marine engines are equipped with a dual cooling circuit. The most important advantage of this system is that the engine block is not in contact with raw water. The heat is transferred to the raw water by heat exchangers.

### 8.2 Raw water pick up and bottom valve

The raw water pick up is to be provided within appropriate distance to the raw water pump of the engine, to avoid a suction of air when the boat rolls.

Maximum (raw water) suction height is recommended to remain below. 1 to 3 ft (0.3 to 1 m) from the waterline for standard installation. However the requirements of appropriate raw water flow through the engine (max. 160 l/min) must be met (refer to specification in chapter general). If required, the suction height may be increased by loop-laying of the suction pipe so that the pump can start filled with water. On top of the loop an air cock is to be provided, which is to be closed when the engine is stopped, to avoid a rising effect. Before starting, the cock is to be opened.

On wooden boats the raw water inlet should preferably be made of red metal (brass unsuited: corrosion due to high zinc content). On steel boats red metal is recommended too. If the materials used for the hull and the raw water inlet are very different, in regard to their galvanic characteristics, the inlet is to be electrically insulated from the hull. Flow area of raw water inlet and screen should be large enough to avoid a throttling causing a reduced water supply to the pump.

The pipe should be laid in smooth curves to avoid unnecessary throttling, and preferably be made of copper-nickel tube. To eliminate tensions, lay it in a curve and terminate it with a reinforced rubber hose at the raw water pump. The hose should be designed with steel spiral, otherwise the underpressure in the suction pipe may cause a collapse of the hose, thus no longer guaranteeing a sufficient natural water supply.

Inside diameter of the floor cock should at least be equal to the suction pipe diameter, see "dimensions raw water pipe". Make sure that the cock does not cause a reduction in flow. On wooden boats, connect the bottom valve to the ship bottom through a board lead-in with through screws. Provide a proper sealing between valve and ship bottom.

- (1) Raw water pick up
- (2) Stop cock
- (3) Hose

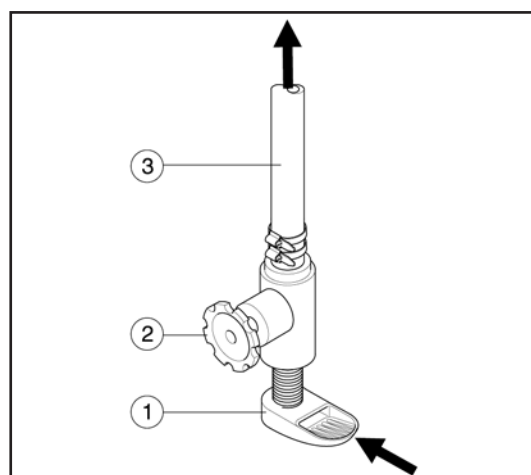

Fig. 117

### **i** Information

On motor boat installation the grid of the water pick up must be aligned to the front (driving direction), therewith on increasing boat speed the water will be pressed into the external cooling system.

On sailing boat installation the grid of the water pick up must be aligned to the rear (aft), therewith water can't be pressed into the external cooling system when the boat is under sailing conditions with stopped engine.

The bottom valve must be closed if the boat rides at anchor.

---

Apply a proper sealing agent, e.g. Permatex, on the screw passages. Sheet boats should have a screwed pipe joint welded to the ship bottom, on which the bottom valve is fastened with screws. On the bottom side, a screen is to be fixed. Apply a proper sealing agent between valve and screwing thread.

When fixing the floor valve, there should be sufficient free space around the valve to permit an easy opening and closing of the valve. If this space is too small, an intermediate piece can be fixed below the valve. In many cases a remote control will be required.

### 8.3 Raw water filter

During coasting trade, on the pier etc., it cannot be avoided that small particles of mud, sand and other dirt enter into the water inlet.

A filter in the suction pipe must be fitted so that these contaminations can be separated. A raw water filter also helps to increase the pump life, thus preventing engine defects due to insufficient cooling water supply.

The figure beside shows one of the Sherewood filters which may be installed with easy access in a bulkhead.

In case of severe contaminations, it may be necessary to install a filter of special size.

Dimensioning of raw water filter:

The minimum required flow through the filter is 160 l/min.

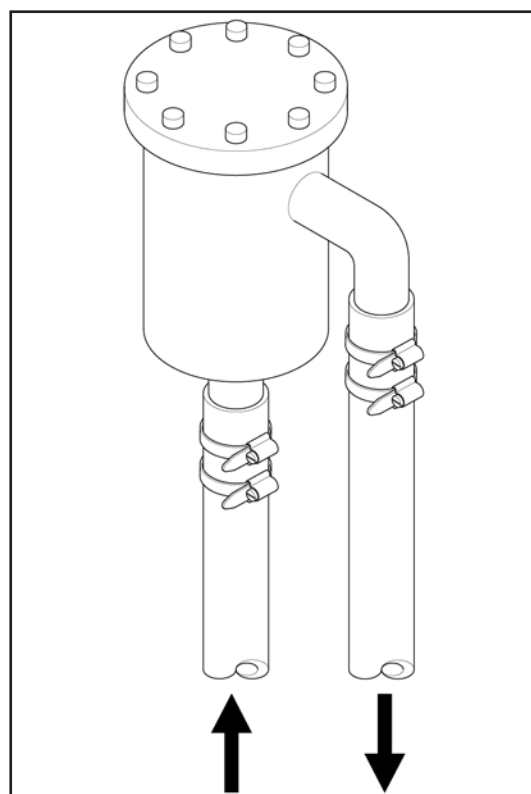

Fig. 118

### 8.4 Raw water pipe

Raw water pipe dimensions in mm and inches	4 & 6 cylinder engines	
Suction and pressure pipe, inside diameter	32 mm	1 ¼ "
Suction and pressure pipe, outside diameter	42 mm	1 ⅝ "
Min. rate of flow of raw water in l/min and gal/min	> 150 l/min	> 40 gal/min

### 8.5 Exhaust connection

All **Steyr Motors** marine engines are equipped with a water cooled exhaust gas elbow, as shown in the figure below. At the exhaust gas muzzle the raw water is injected into the tail pipe for cooling of the exhaust gases.

When designing the exhaust elbow particular importance was given to a relatively high exhaust duct in order to avoid the entering of back wash. In the adjoining exhaust pipe a splash flap is to be installed in addition.

In case of insufficient difference in level between exhaust gas outlet and sea water surface (boat loaded) a high riser exhaust elbow (optional) is to be installed.

See section 10 Exhaust system.

- (1) Exhaust gas elbow
- (2) Connecting piece
- (3) Splash flap
- (4) Tail pipe with flange

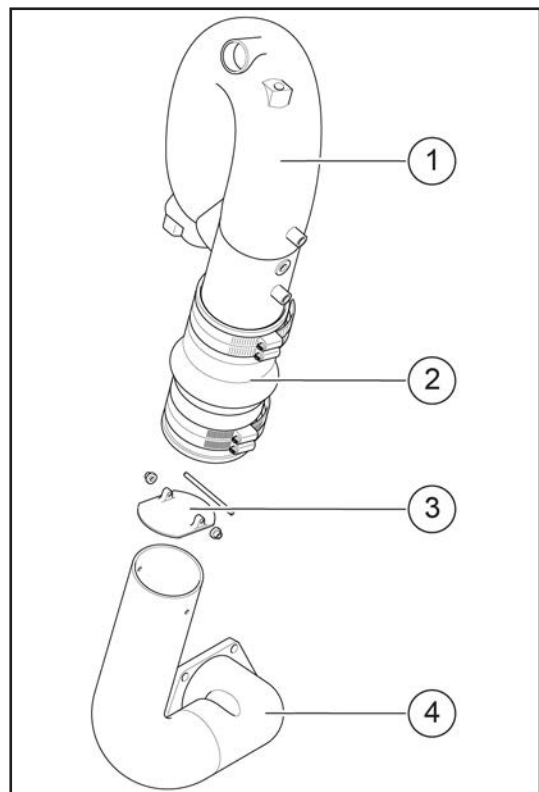

Fig. 119

## 8.6 Additional cooling circuits on engines

Installation of a tandem-/triple-cooler (see schematic raw water circuit 2181159-0) on a **Steyr Motors** engine is capable of providing up to a 3 % gain in engine power.

### 8.6.1 Standard gear box cooling from Steyr Motors

**Steyr Motors** provides oil cooling connections for corresponding gear box models as mentioned in the spare parts catalogue of the selected engine model.

Use oil cooling connections only for the gear box models as specified in the spare parts catalogue.

## 8.7 Scheme of raw water cooling with gear box

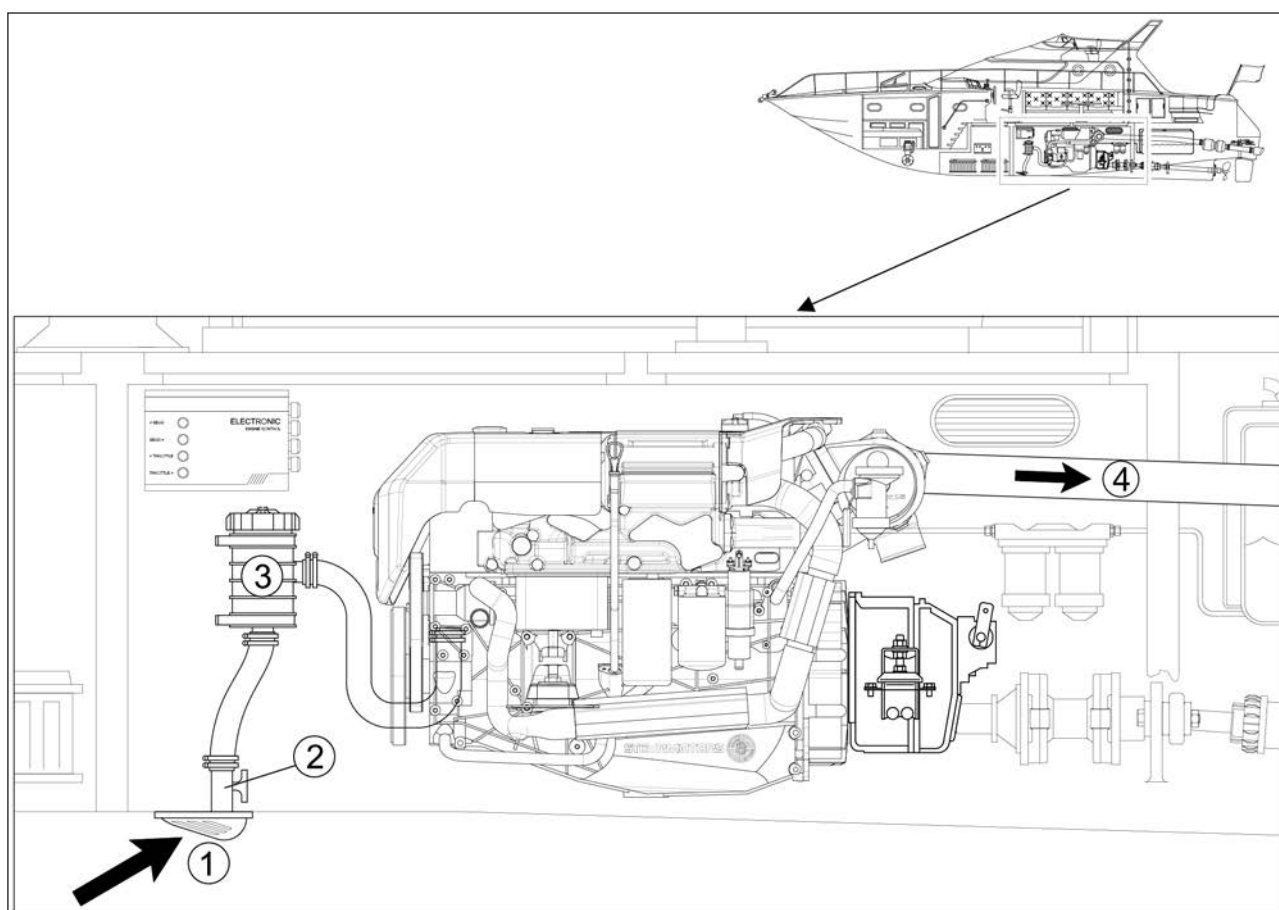

Fig. 120

Pos.	Description	Pos.	Description
1	Raw water inlet	2	Bottom valve
3	Raw water filter	4	Exhaust- and raw water gate



## 8.9 Scheme of raw water cooling with jet drive

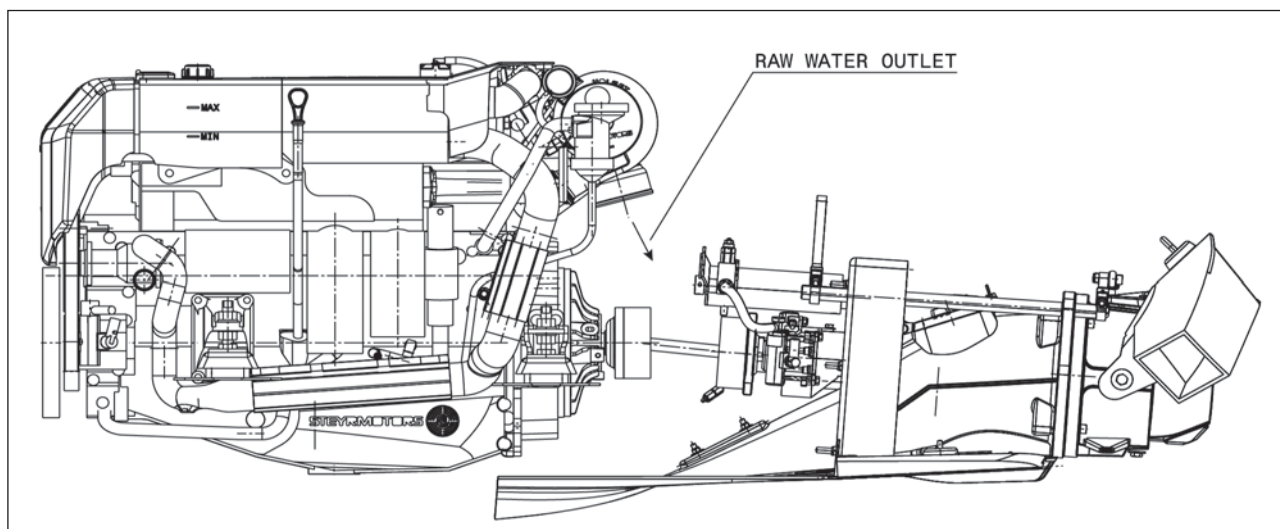

Fig. 122

If raw water is picked up by jet drive, the engine's raw water pump is not required. Mount raw water supply over jet to raw water circuit of engine.

If raw water pump additionally used:

- Ensure impeller is dismounted.
- Keep recommended raw water supply (>140 l/min) due to power loss over raw water pump.

---

### **i** Information

- ▶ Take care for pressure-rate of raw water filter if raw water is supplied over jet drive and raw water filter is mounted on pressure side.

---

### **i** Information

Raw water intake engine:

- ▶ Max. 2.0 bar supply pressure!

### 8.10 Scheme of cooling with keel cooler

**Steyr Motors** marine engines can also be used with a keel cooling system (Keel cooler and external parts are not included). A set with the required parts (e. g. 6 cylinder SMO no. MS1111050) related to the engine can be ordered from **Steyr Motors**.

The **Steyr Motors** keel cooling system uses two cooling circuits: One high temperature (HT) circuit for the engine water and one low temperature (LT) circuit for charge air, fuel, and transmission oil cooling.

The LT circuit uses the raw water pump. For maintenance intervals see **Steyr Motors** Operation, Maintenance and Warranty Manual (SMO No. 707245). The LT circuit is pressurized. An expansion tank with a pressure cap has to be used.

The HT circuit uses the engine water pump. For the HT circuit, an additional expansion tank is needed. The standard expansion tank, which is mounted on the engine, can not be used because the volume is too small. The pressure cap on the HT expansion tank must have a minimum release pressure of 1.4 bar relative.

If the exhaust system is not water cooled, especially consider chapter [10.3 Dry exhaust pipe and chapter](#) and [10.5 Dimensions for exhaust pipe connection](#).

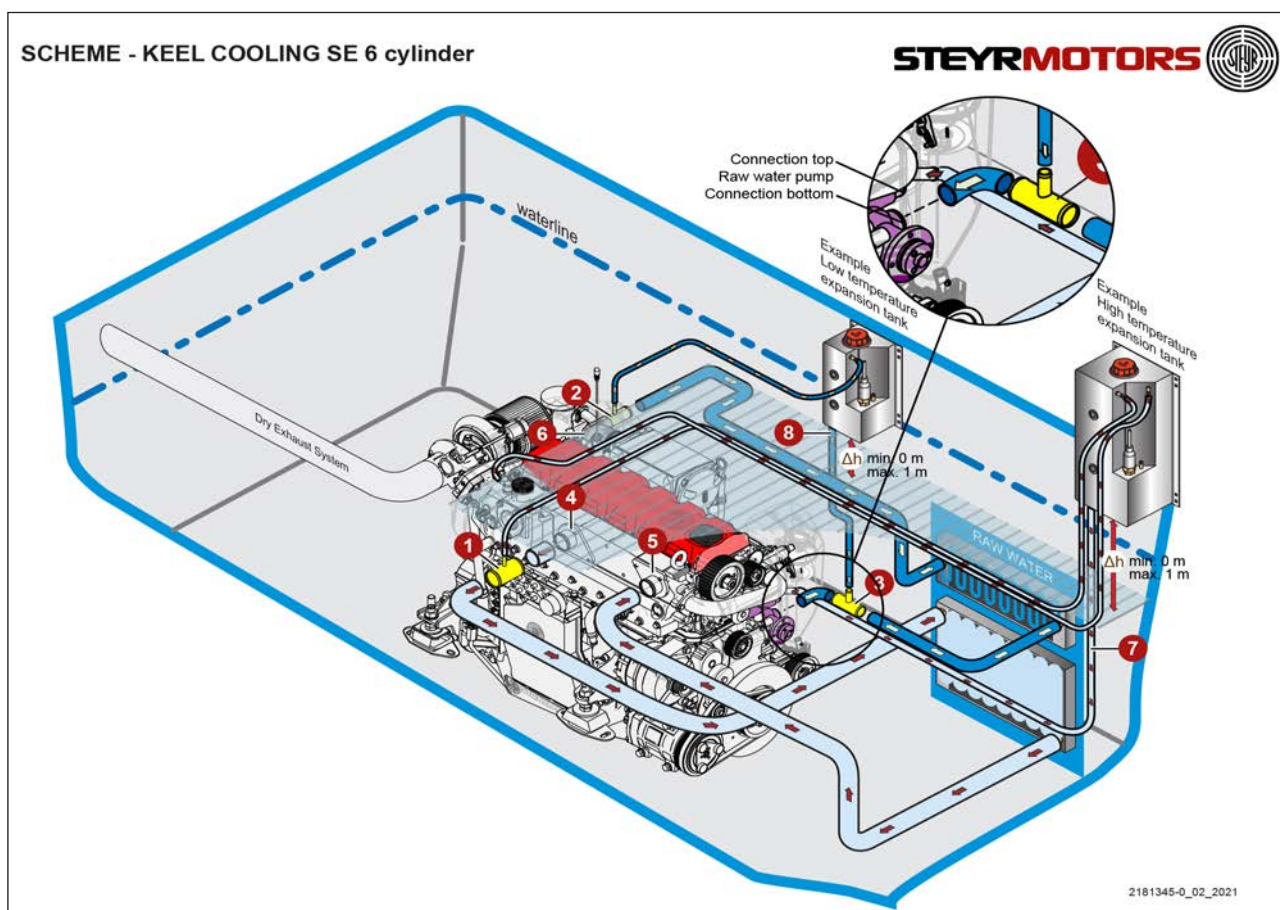

Fig. 123

Pos.	Description
1	Pipe engine coolant 50-8
3	Pipe engine coolant 32-16
5	Bracket, keel cooling inlet
7	Suction line HT-circuit Ø 16 mm
●	High temperature circuit

Pos.	Description
2	Pipe engine coolant 32-8
4	Bracket, keel cooling outlet
6	Moulded hose, heat exchanger pipe
8	Suction line LT-circuit Ø 16 mm
●	Low temperature circuit

## Cooling System

### 8.10.1 Keel cooling dimensioning

For dimensioning of the keel coolers the following table can be used. This information can also be sent to the keel cooler supplier. For further information please contact a **Steyr Motors** service agent.

**NOTE:** For maintenance and mounting position for keel coolers, consider the manufacturer`s instructions.

Keel Cooler / Radiator & Expansion Tank Specification										
		SE306J38	SE286E40	SE266S36	SE266E40	SE236S36	SE236E40	SE186E38	SE156E34	SE126E32
Application		Marine 6 cylinder								
Displacement	[liter]	3.2								
Rated power	[kW]	215	205	190	190	170	170	129	113	88
Rated speed	[rpm]	3800	4000	3600	4000	3600	4000	3800	3400	3200
<b>High temperature circuit keel cooler for engine coolant heat</b>										
Type of cooler		Coolant / Raw water								
Type of coolant		Glycol - water (50/50)								
Max. engine outlet temperature	[°C]	90								
Heat to be dissipated from engine coolant	[kW]	181	180	165	167	145	149	109	95	74
Coolant mass flow at rated speed	[l/min]	190	200	180	200	180	200	190	170	160
Max. pressure drop of keel cooler	[mbar]	350	350	350	350	350	350	350	200	200
Max. pressure drop of piping to keel cooler	[mbar]	100								
Max. raw water temperature *	[°C]	35								
Pressure cap / Expansion tank	[bar <sub>rel</sub> ]	1.4								
Minimum reached pressure build up **	[bar <sub>rel</sub> ]	0.7								
<b>Low temperature circuit keel cooler for charge air, oil, fuel, transm. cooling</b>										
Type of cooler		Coolant / Raw water								
Type of coolant		Glycol - water (50/50)								
Max. coolant (charge air cooler) outlet temperature (NOT TO EXCEED)	[°C]	40								
Heat from charge air and fuel	[kW]	53.5	54.5	51	51	45	45	32	28	22
Heat from transmission oil	[kW]	Depends on application, has to be added to the value above								
Coolant mass flow at rated speed	[l/min]	150	160	145	160	145	160	150	135	130
Max. pressure drop of keel cooler	[mbar]	300	300	300	300	300	300	300	250	250
Max. pressure drop of piping to keel cooler	[mbar]	200	200	200	200	200	200	100	100	100
Max. raw water temperature *	[°C]	35								
Pressure cap / expansion tank	[bar <sub>rel</sub> ]	0.8								
Minimum reached pressure build up ***	[bar <sub>rel</sub> ]	0.3								

\* Depends on keel cooler efficiency

\*\* Under all boundary conditions /checked at min. filling level and max. specified ambient temperature, calculated at 80 °C engine coolant temperature

\*\*\* Under all boundary conditions /checked at min. filling level and max. specified ambient temperature, calculated at 50 °C coolant temperature

## 9 Fuel system

### 9.1 General

Assembly of the individual components of the fuel system must ensure an optimum sealing and fire-resistance. Before starting these works, plan the location as well as the type of fuel tanks. Ensure high quality in order to avoid a leakage of fuel on the cocks. A leaking fuel system is a fire risk and can lead to ongoing issues.

#### Materials

All component surfaces in direct contact with the fuel must not contain copper (Cu), zinc (Zn) or lead (Pb), as far as technically possible. Copper containing materials in particular act to catalytically accelerate the ageing process of diesel fuel. The resulting fuel ageing, especially with admixtures of FAME, can lead to deposit formation and corrosion inside the fuel injection equipment. Zn or Pb dissolved out of materials may lead to increased deposit formation.

The fuel quantity may be split between several fuel tanks, thus keeping the center of gravity low and retaining certain trim potentials for the hull.

When installing the fuel tanks, adequate room is to be provided with ventilation. Connect filling fixture and tank with an impregnated (diesel fuel resistant) cable, unless being already connected electrically. Also provide grounding of the tank.

When planning the assembly, always try to store the tanks in a separate area in order to minimize the risk of fire in case of a fuel leakage.

For assembly of the fuel tanks, proceed with great care, to avoid leakage or water infiltration.

**Steyr Motors** insist that a fuel prefilter with water separator function is fitted into the fuel system before the fuel supply pump, as drops of water in the fuel are ideal transporters of dirt and rust through narrow pipes. One drop of water may cause a locking of the fuel supply pump, thus cutting the fuel supply. Particularly, with diesel engines, small deposits of dirt or rust may result in heavy damages on the injection pump and nozzles.

The operator should check the water separator daily and drain if necessary. Once the water separator is full, it will no longer work properly until it is drained.

The fuel prefilter with water separator should be installed as close as possible to the tank, but with enough space for water drainage and exchange of filter inserts.

## Fuel System

For selection and dimensioning of filters and water separator fuel systems, follow the table below.

Pre-Filter Specification	6 cylinder engine	4 cylinder engine
Flow rate	330 l/h	≥ 240 l/h
Min. Water separation efficiency	93 % (according to ISO 4020, out of emulsified water, at max. flow rate)	
Min. particle filtration efficiency	10 % ( according to ISO TR13353:1994 3 - 5 µm at max. pump flow rate)	
Max. suction pressure	0.5 bar	
Max. pressure loss at filter (new)	50 mbar	
Max. pressure loss at filter (used)	200 mbar	

## Overview

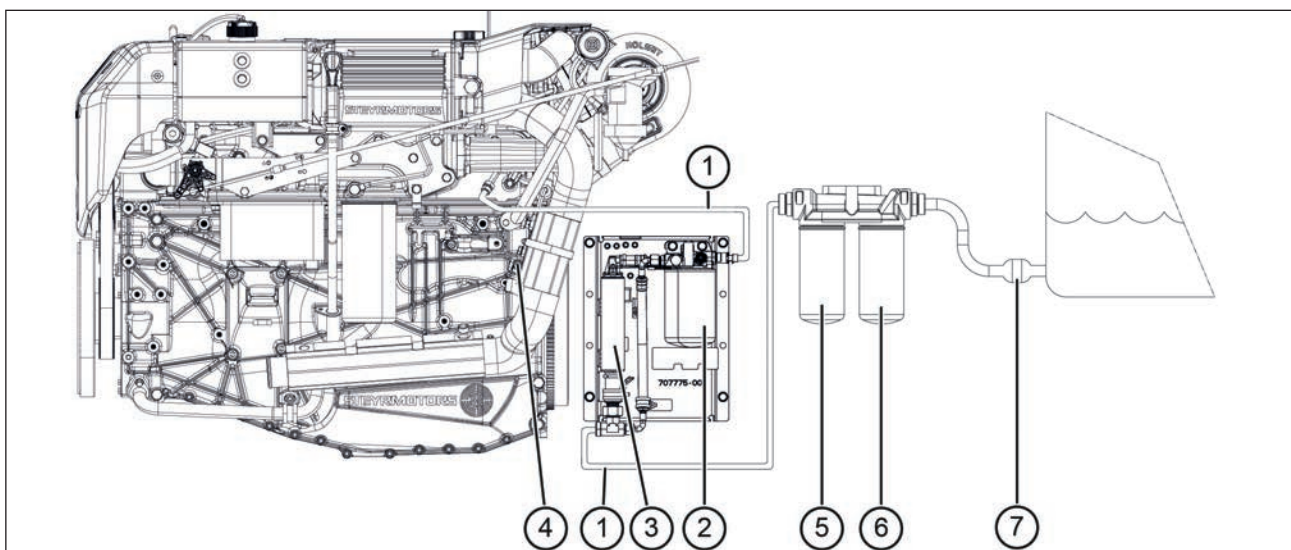

Fig. 124

Pos.	Description	Pos.	Description
1	Feed line	2	Fuel filter
3	Fuel supply pump	4	Fuel return
5	Coarse filter	6	Water separator
7	Anti siphon valve		

## 9.2 Fuel tank(s)

If possible, arrange the fuel tanks at engine level or higher. In case of a lower arrangement, max. suction height of the feed pump is to be considered, which is 19.7 " (0.5 m) for all kinds of engines. Please consider that the suction height is calculated from the lower end of the suction pipe, i.e. approx. 1 " (2.5 cm) over the tank bottom. The return pipe should lead into the tank at the level of the screen but with some distance to it, to avoid a foam formation of fuel.

In case of arrangement of the tanks at a level lower than the admissible suction height of the feed pump, the fuel is to be pumped up to a daily tank by a manually operated pump or motor pump. In this case, the fuel flowing back from the engine is pumped into the daily tank.

If possible, the fuel tanks should be made of stainless steel (Nirosta). Light metal, steel plate or plastic may be used too.

Copper plate, galvanized or pot-galvanized plate are not suitable materials for fuel tanks.

---

### **NOTICE**

If demanded by the US COAST GUARD install an anti-siphon valve which must be opened by fuel supply pump suction to withdraw fuel from the tank and which will remain closed without fuel supply pump suction, preventing siphon action created by a break at any point in the fuel feed system.

The valve shall be designed and sized to provide the required fuel flow rate to the engine and should have an open pressure as small as possible.

---

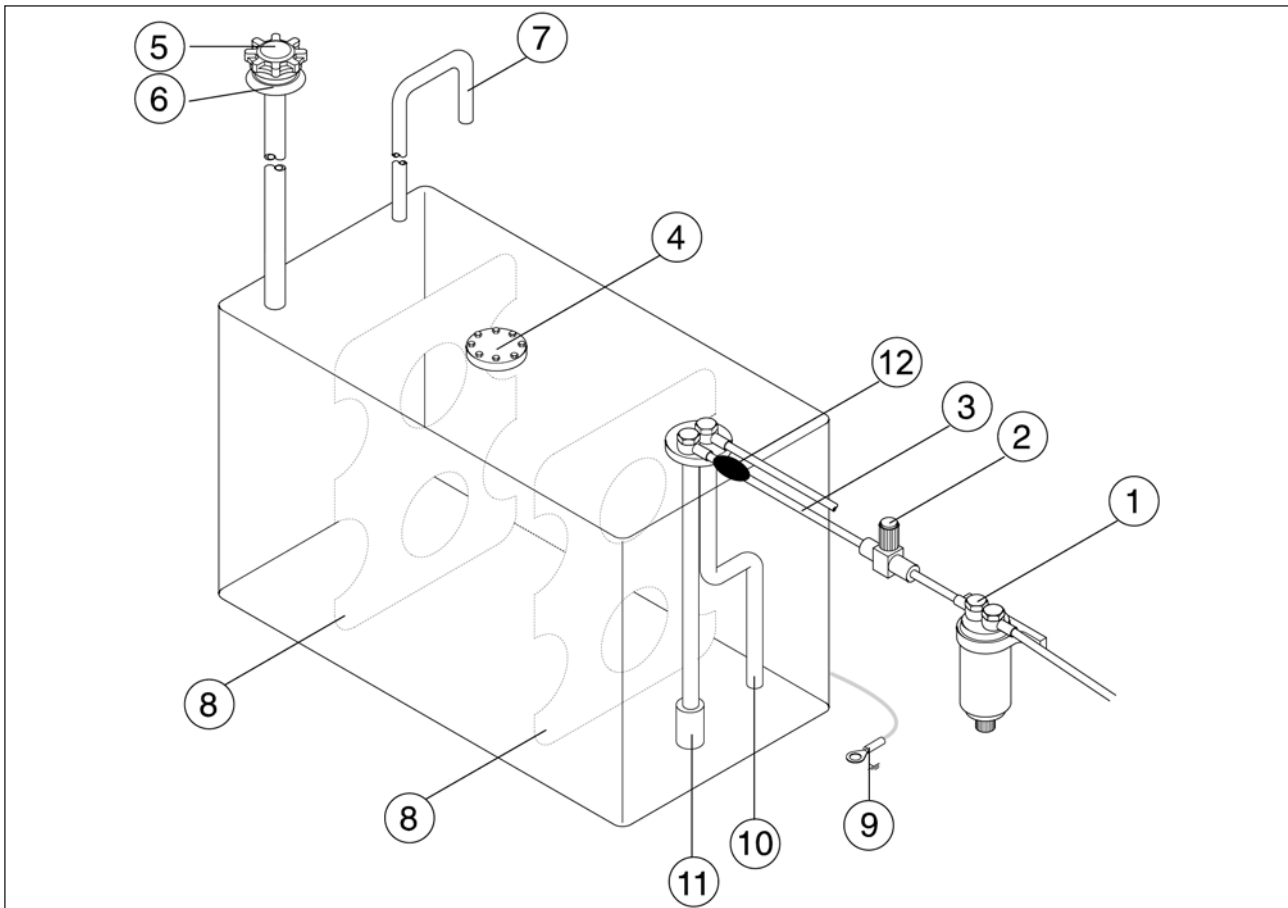

Fig. 125

Pos.	Description
1	Water separator, rate of flow > 72.6 Brit. gal/h (> 330 l/h) * <b>see chapter 9.1</b>
3	Fuel pipe, inside diameter 0.63 " (16 mm) for a length of 20 ft (6 m)
5	Filler socket cover
7	Air-vent pipe, diameter at least 1 ½ " (38 mm)
9	Ground connection
11	Suction pipe, complete with screen [distance to tank bottom 1 " (25 mm)]

Pos.	Description
2	Fuel stop cock
4	Inspection cover
6	Lead-in sleeve made of fuel-resistant rubber, with drain possibility
8	Guide bulkhead
10	Return pipe
12	Anti-siphon valve

### 9.3 Twin fuel tanks

For a lateral arrangement of the tanks in the boat, a construction according to the figure below may be chosen.

Connect the tanks on top and on bottom with pipe lines equipped with stop cocks. A minimum inside diameter of the lower connecting pipe should be  $\frac{3}{4}$  " (19 mm) in order to permit filling of the tanks from either side of the boat if they are installed alongside each other.

The fuel pipe from the engine has to depart from the lower connecting pipe of the tank (only valid for tanks with bottom drain). An additional fuel filter or water separator is to be installed before the feed pump on the injection pump.

In case of a daily tank, it is recommended to connect the fuel return pipe to this tank which reduces the filling intervals.

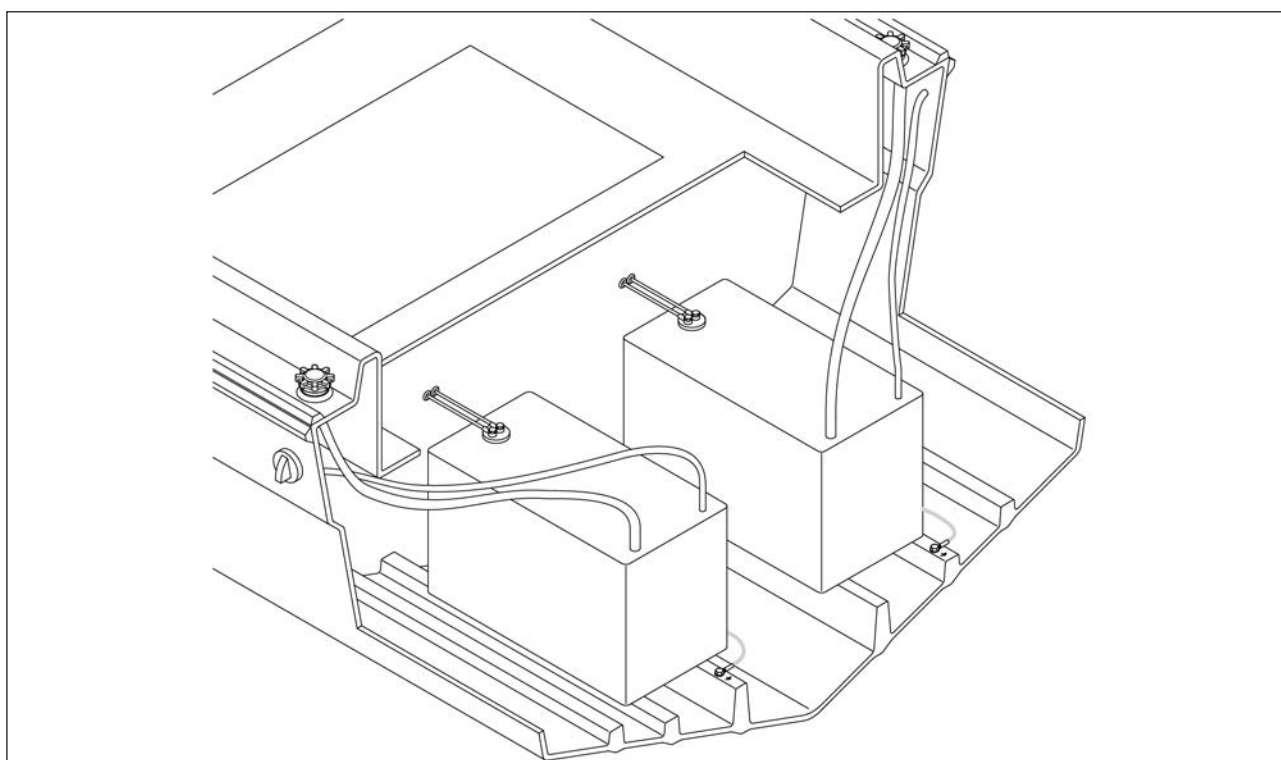

Fig. 126

### 9.4 Fuel pipes

The minimum inside diameter of the fuel filler socket should be 1 ½" (38 mm). Length of the socket should be chosen in such a way that the distance to the tank bottom is approx. 2" (50 mm). Connect the filler socket from the tank to the deck union by means of a pipe joint to the tank socket. On the deck lead-in a sleeve made of fuel-resistant rubber is to be provided. If possible, rubber hoses should be avoided. When using a rubber hose, it should be of fuel-resistant, reinforced quality. Always connect the tank and deck union by a grounding cable, unless there is a metallic contact.

The air-vent pipe is to be laid from the highest point of each tank to a protected area on deck. On the upper end of these pipes a curve of 180 ° is to be provided, which prevents water entering the tanks. The air-vent pipes should also be arranged in such a way that e. g. gas flowing out cannot be ignited or enter into the rooms aboard.

The fuel pipes for the engine should be made of steel tubes. Tubes made of copper are not suitable for fuel pipes (refer to fuel system, general, section materials). The hose pipes have to comply with specific conditions of use and respective local waterway regulations (see hints in the preface).

#### Specific data for fuel hoses

- Synthetic rubber hose with plies of fabric
- Size DN 8 (pressure side of fuel supply pump)
- Resistant to Diesel fuel according to EN590
- Fire proof
- Temperature range: – 30 to + 100 °C (or higher)
- Operating pressure 145 psi (10 bar)

The maximum permissible suction pressure of 250 – 300 mbar should be not exceeded at the connection of the fuel supply pump! The amount of suction pressure depends on different installation conditions, on used fuel as well as on the diameter of the suction line.

Steyr Motors recommends following pipe or hose dimensions on the suction side:

Inner diameter of the fuel suction pipe	6 cylinder engine	4 cylinder engine
Up to lengths of 20 ft	12 mm	8 mm
Longer then 20 ft	16 mm	10 mm

The fuel overflow valve on the engine requires a fuel return pipe to the tank to be laid (or to the daily tank if one is installed). Min. inner diameter of the fuel return pipe should be 0.32" (8 mm).

---

#### **NOTICE**

The correct suction pressure must be checked after installation!

---

Fuel pipes are already mounted on the engine side.

Fuel pipe with brazed tapered piece

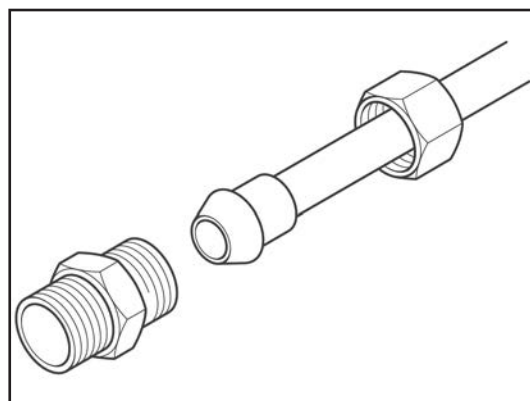

Fig. 127

Flanged fuel pipe

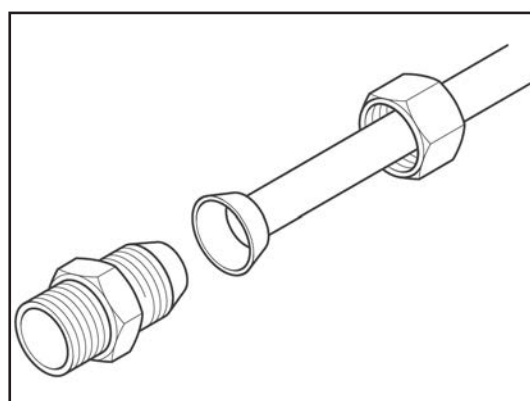

Fig. 128

The connections of the fuel pipes are to be flanged with a special tool. Loose or soft soldered tapered pieces must not be used. When using tapered pieces, these are to be fixed on the pipes by brazing. However, the best solution is a flanging of pipes. Fasten the fuel pipes to planks or rigid supports to avoid vibrations or pipe fracture.



## 10 Exhaust system

### 10.1 General

Install the exhaust system using as few bends as possible. Maximize the curve radius of the required bends where possible. Provide sufficient pipe diameter to keep the back pressure within admissible values.

The exhaust system may be designed in 3 different ways:

- **Dry exhaust pipe, insulated**
- **Wet exhaust pipe (water flow in the pipe)**
- **Exhaust pipe with water jacket (double-walled, water-cooled)**

The dry exhaust pipe releases large amounts of heat into the engine compartment thus requiring good insulation. The wet exhaust pipe and the exhaust pipe with a water jacket are cooled and therefore mostly do not need insulation. The water flow in the exhaust pipe also has a noise-absorbing effect.

### 10.2 Materials

Exhaust gases from a Diesel engine also contain sulfur compounds, when mixed with water, may corrode the metals. For this reason, copper tubes are unsuited for exhaust pipes.

Exhaust pipes with cooling jackets are to be made of acid-proof steel tubes to guarantee satisfactory service life. In the case of water inlets into the exhaust pipe, the line may be made completely or partially of special exhaust rubber hose.

Dry exhaust pipes are preferably made of acid-proof steel tubes. Pipes made of stainless or galvanized steel tube also guarantee a relatively satisfactory service life.

### 10.3 Dry exhaust pipe

Scheme of a dry exhaust pipe for 2 engines

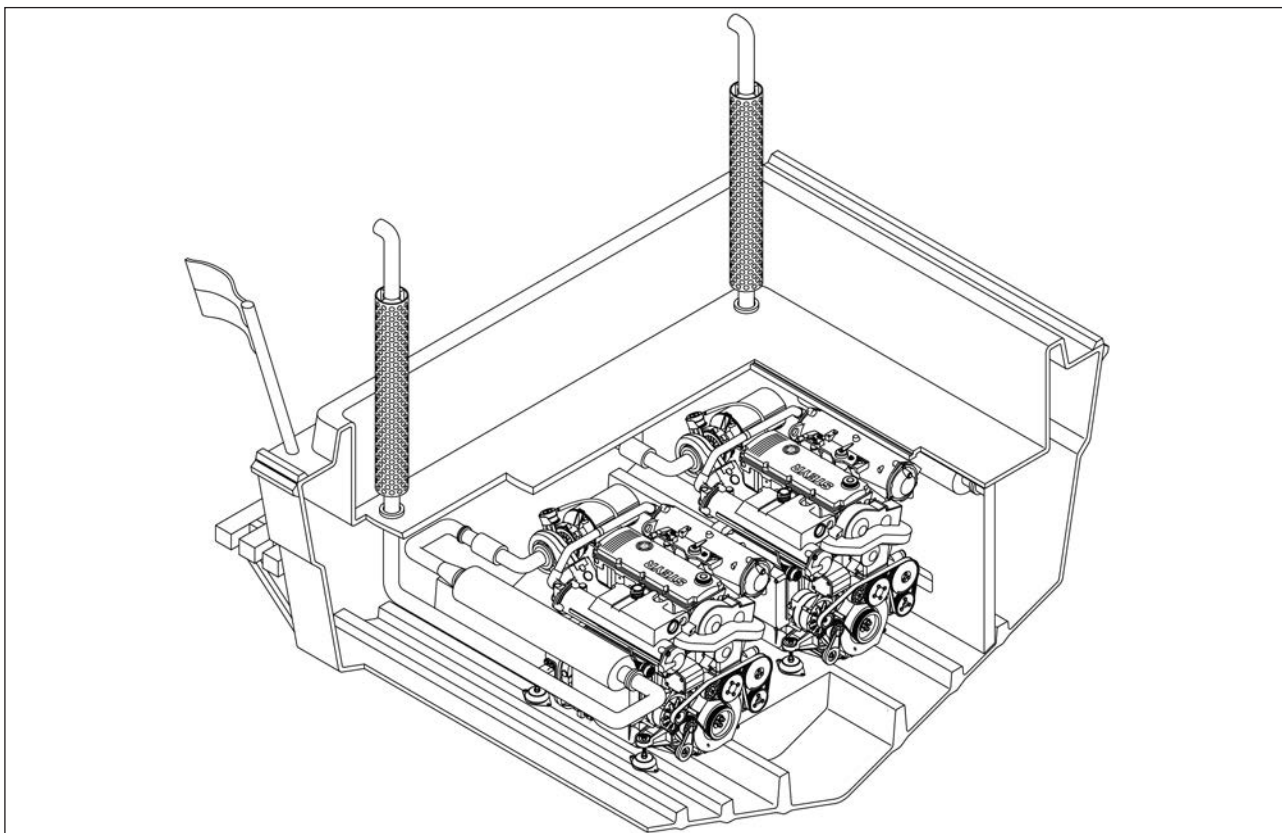

Fig. 130

## 10.4 Wet exhaust pipe

Wet exhaust pipes for turbo engines are designed according to figure below.

All rubber hoses are to be connected at each end by 2 corrosion-resistant hose clamps.

Wet exhaust pipe with muffler TWIN-MI 236 TD (example):

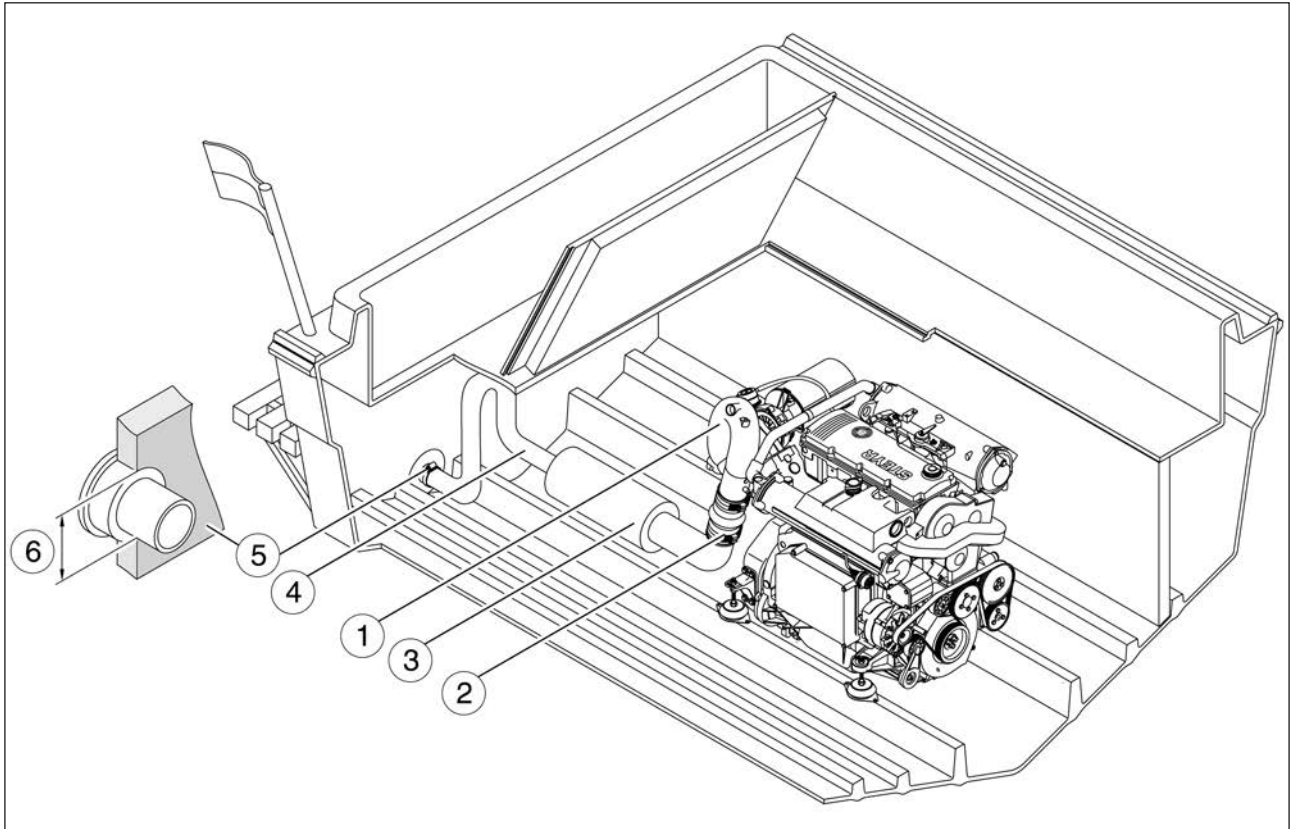

Fig. 131

Pos.	Description	Pos.	Description
1	Wet exhaust elbow	2	Exhaust rubber hose
3	Water-cooled muffler	4	Exhaust pipe, bend over water line
5	Board lead-in with rubber expansion piece sealing the bore in the boat transom	6	Bore diameter in boat transom 5" ± 0.5 line (127 ± 1 mm)

All exhaust pipe types must be assembled ensuring water is not able to enter the engine from the exhaust, otherwise severe damage to the engine due to hydro lock and cylinder corrosion may occur.

### CAUTION

When laying the exhaust pipe through bulkheads and similar, make sure that the pipe does not touch material which transmits vibrations onto the hull, thus causing resonance noise. In the case of lead-in pipes, take special care that the exhaust pipe will not cause a combustible heating of the surrounding material.

---

### CAUTION

For the assembly of exhaust pipes to turbo charged engines; The turbo charger must never have to support the weight of the exhaust system.

---

#### 10.4.1 Exhaust for inboard engines above water line

The exhaust outlet in the hull should be 12 " (300 mm) below the exhaust elbow.

For correct installation, the highest part of the exhaust system must be at least 12 " (300 mm) above the water line with a loaded boat, see figure below.

Install the drain cocks at the lowest points of the exhaust pipe.

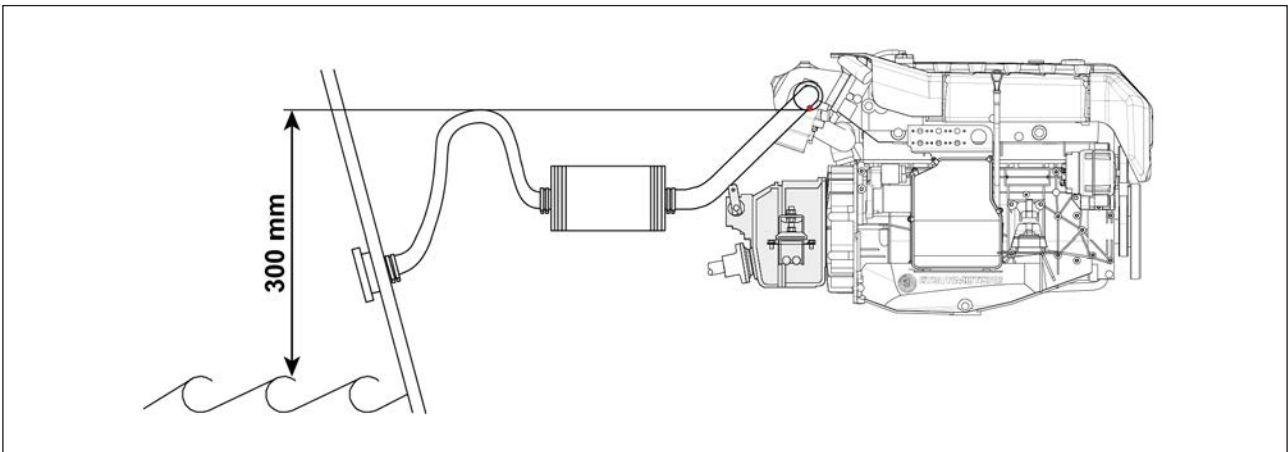

Fig. 132

10.4.2 Exhaust for inboard engines below water line

Variation A - combined water lock / muffler

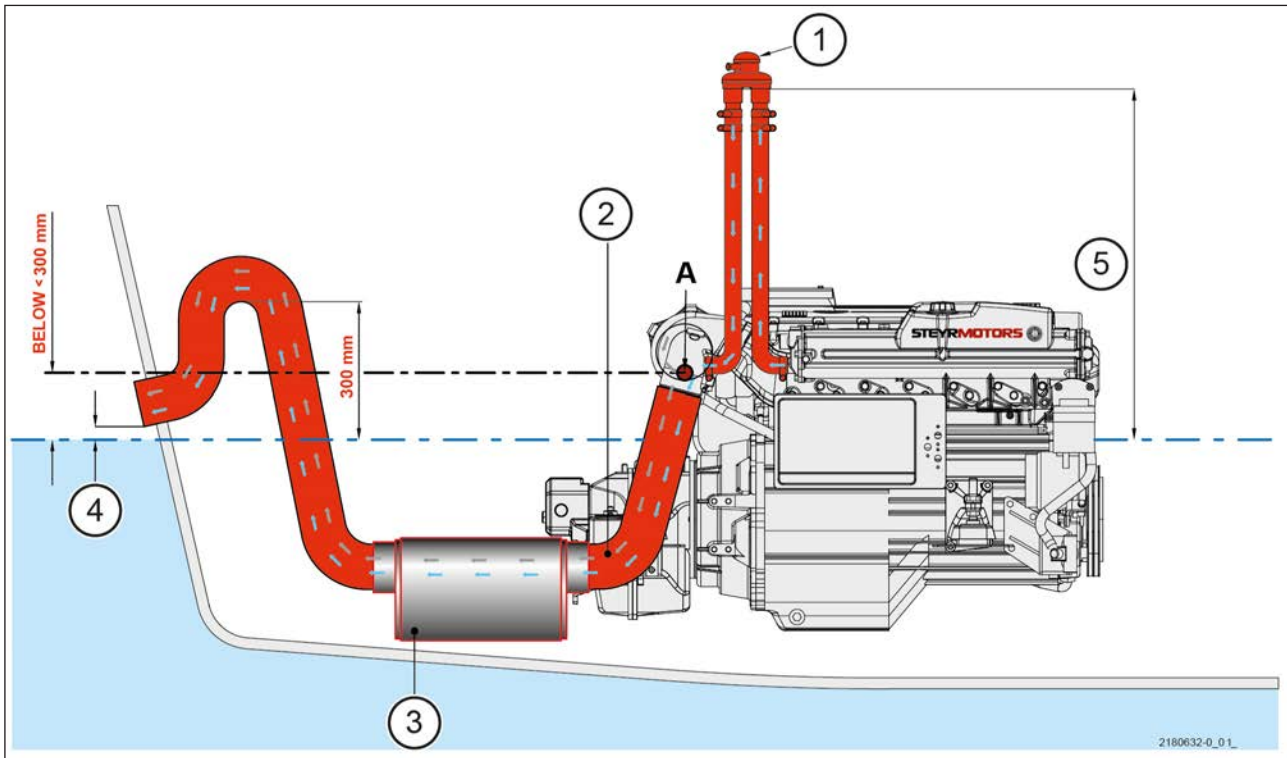

Fig. 133

Pos.	Description	Pos.	Description
1	Air vent	2	Exhaust between water lock / muffler and Steyr Motors exhaust elbow has to compensate water amount of hose between exhaust elbow and air vent.
3	Combined water lock / muffler - has to compensate water - amount from exhaust / boat to water lock / muffler	4	Height to be defined by installing party.
5	Height to be defined by installing party.		
A	Reference point "A" = 300 mm above waterline or lower		

Installation of air vent and exhaust system must be designed by the installing party so that no back flash-water enters the exhaust system of engine during operation and engine stop.

## Exhaust System

### Variation B - water separator and muffler

(Recommended for long wet exhaust systems)

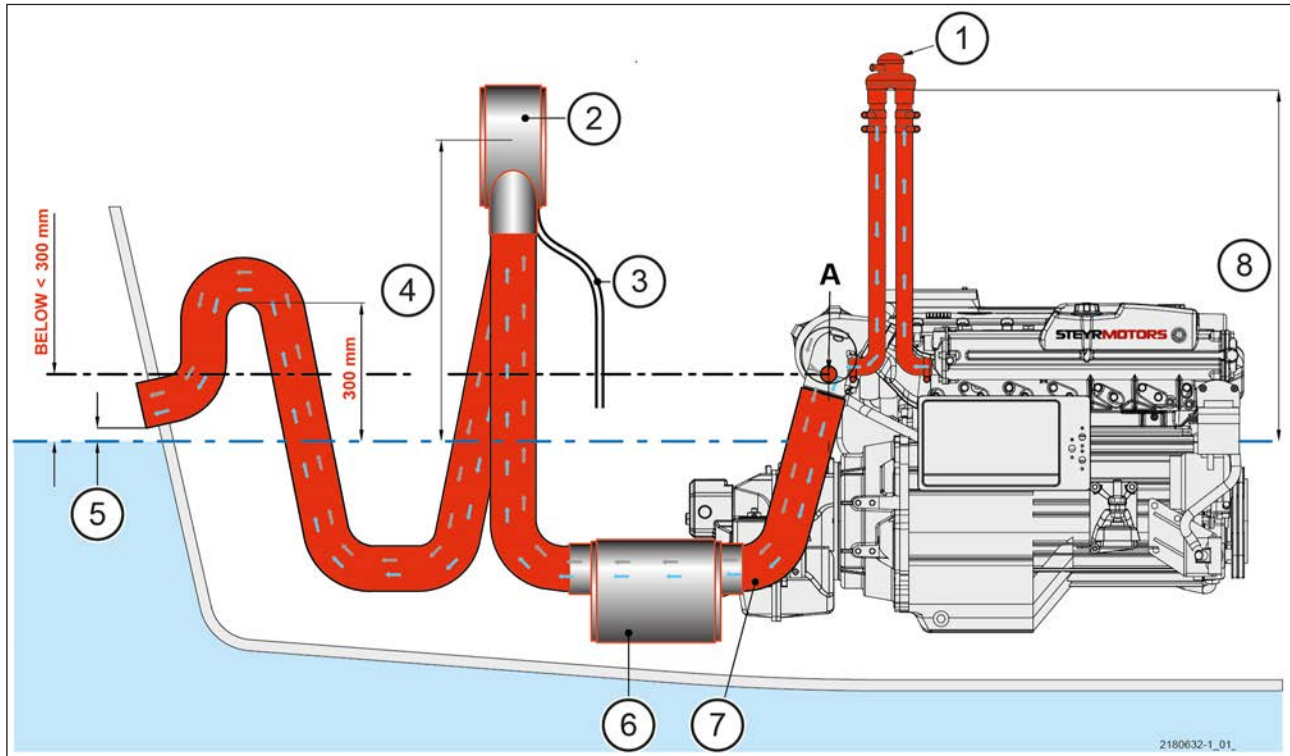

Fig. 134

Pos.	Description
1	Air vent
3	Water drain
5	Height to be defined by installing party.
7	Exhaust hose between water lock / muffler and <b>Steyr Motors</b> exhaust elbow has to compensate water amount of hose between exhaust elbow and air vent.
A	Reference point "A" = 300 mm above waterline or lower

Pos.	Description
2	Water separator (ev. inclusive air vent) - has to compensate water - amount between exhaust / boat to water separator
4	Height to be defined by installing party.
6	Muffler - has to compensate water - amount from water separator to muffler
8	Height to be defined by installing party.

### 10.4.3 Exhaust for stern drive engines

Precondition for a correct installation is compliance with the min. height **(A)** of 14 " (350 mm) from the exhaust system highest point to the water line A (see figure below). If required, launch the boat with its real load resp. load distribution (weight of drive unit plus working load) in order to determine the water line.

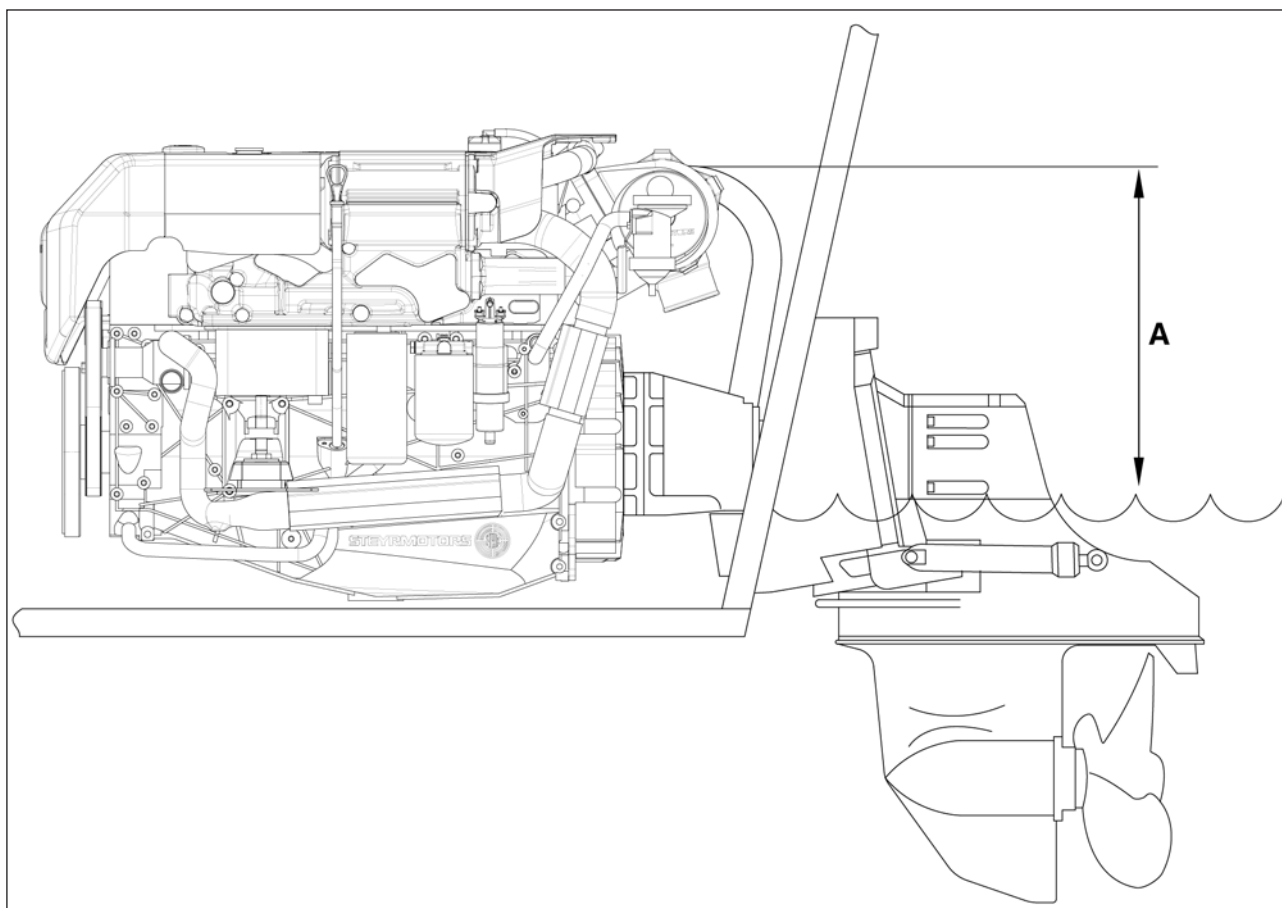

Fig. 135

## 10.5 Dimensions for exhaust pipe connection

### 10.5.1 Wet exhaust pipe

Overview

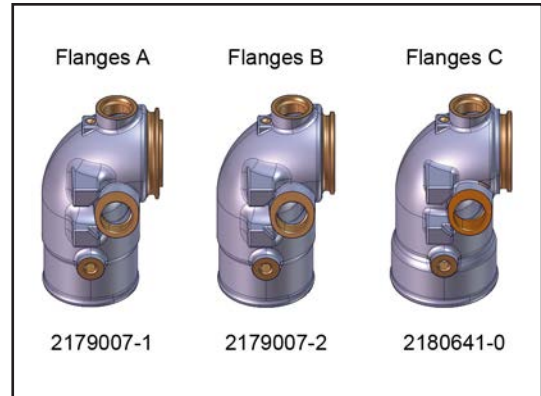

Fig. 136

#### Flanges A (SMO no. 2179007-1)

**Engine**

SE126E32

SE156E34

SE186E38

SE236E40

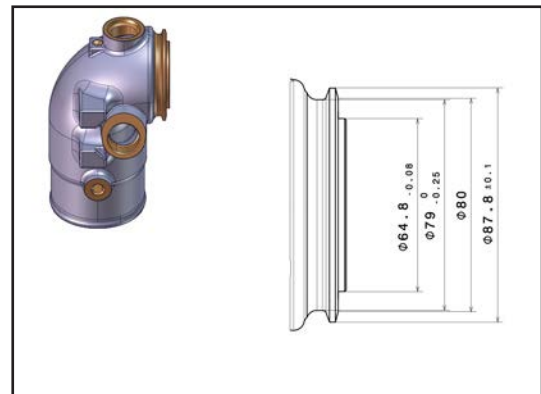

Fig. 137

Exhaust pipe inner & outer diameter by conventional wet exhaust elbow

**Engine**

SE126E32

SE156E34

SE186E38

SE236E40

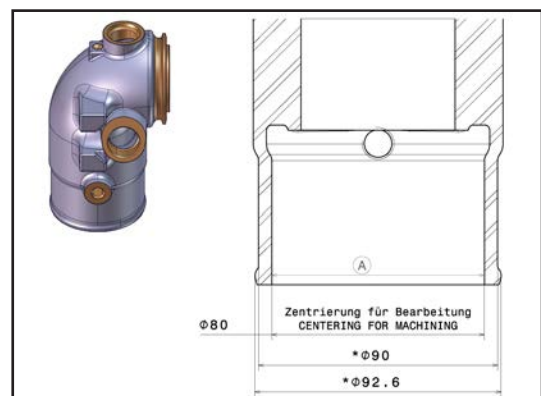

Fig. 138

**Flanges B** (SMO no. 2179007-2)

**Engine**

**SE236S36**

**SE266E40**

**SE266S36**

**SE286E40**

**SE306J38**

**SE144E38**

**SE164E40**

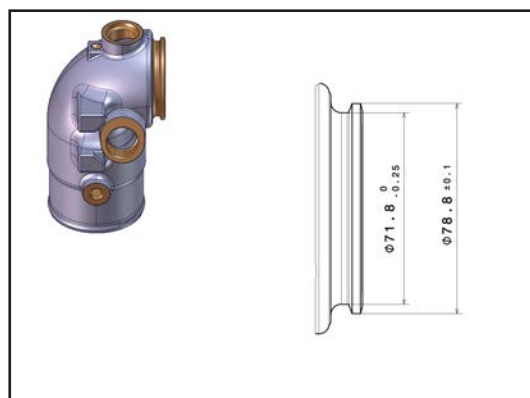

Fig. 139

Exhaust pipe inner & outer diameter by conventional wet exhaust elbow

**Engine**

**SE236S36**

**SE266E40**

**SE266S36**

**SE286E40**

**SE306J38**

**SE144E38**

**SE164E40**

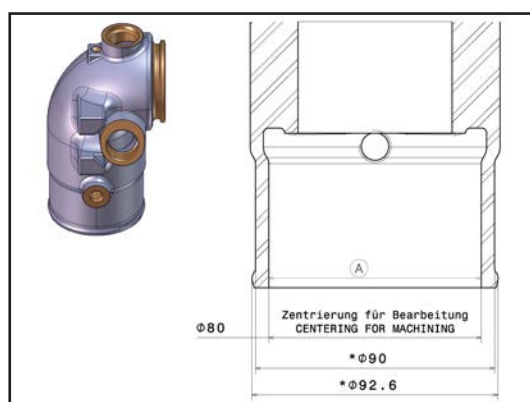

Fig. 140

## Exhaust System

### Flanges C (SMO no. 2180641-0)

#### Engine

SE236S36

SE266E40

SE266S36

SE286E40

SE306J38

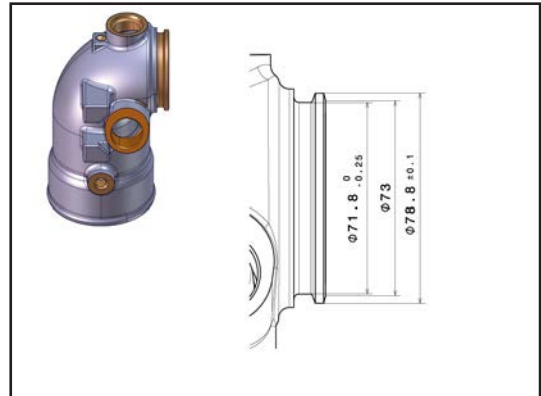

Fig. 141

Exhaust pipe inner & outer diameter by conventional wet exhaust elbow

#### Engine

SE236S36

SE266E40

SE266S36

SE286E40

SE306J38

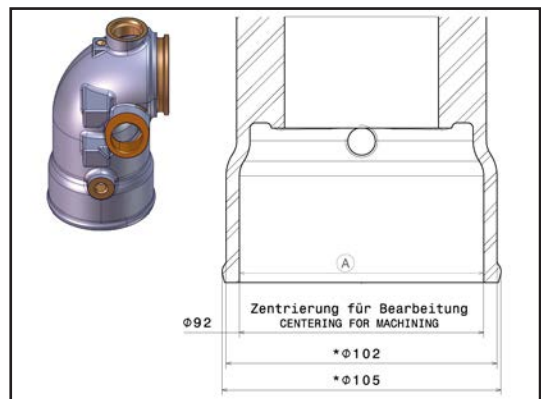

Fig. 142

	mm	inch
Wet exhaust pipe (industrial rubber hose)*	90	3.5"
Outside diameter	102	4.0"

\* Outside diameter valid for all exhaust elbows and high riser exhaust elbows supplied from **Steyr Motors**.

### 10.5.2 Measuring of back pressure

After assembly of the exhaust system, always check the back pressure; most simply with a pressure gauge connected by means of an adaptor instead of the exhaust raw water temperature sensor. Measuring is then to be done with nominal capacity of the engine.

The max. admissible exhaust back pressure for **Steyr Motors** marine engines is 1000 mm WS = 100 mbar (WS = water column).

#### Exhaust back pressure:

	Engine Type	Exhaust back pressure* Set-point (mbar)	Admissible tolerance SMP (mbar)	Exhaust mass flow @ rated power (kg/h)
6 cyl.	SE126E32	150	+ 0 / - 50	667.2
	SE156E34	150	+ 0 / - 50	817.2
	SE186E38	150	+ 0 / - 50	941.5
6 cyl.	SE236E40	150	+ 0 / - 50	1037.4
	SE236S36	150	+ 0 / - 50	891
	SE266E40	150	+ 0 / - 50	1077.2
	SE266S36	150	+ 0 / - 50	956.1
	SE286E40	150	+ 0 / - 50	1140.3
	SE306J38	150	+ 0 / - 50	1136.9
4 cyl.	SE144E38	150	+ 0 / - 50	607.0
	SE164E40	150	+ 0 / - 50	697.5

\* measured 100 - 250 mm (4 - 10 ") after turbo-outlet in a straight exhaust pipe section

### 10.6 Condensed-water collector

Exhaust gases of an internal-combustion engine contain water vapour which may condense and be converted into water, which in the worst case, flows back into the engine with an exhaust pipe inclined in direction of the engine. Therefore, always install a condensed-water collector behind the water-cooled stand bend. Provide the condensed-water collector with a cock or a drain plug at its bottom.

Min. diameter of the condensed-water collector should be 1 " (25 mm) and its length 12 " (300 mm).



## 11 Air intake and ventilation

### 11.1 General

Power of the engine is influenced by a number of different factors. The most important ones are air pressure, air temperature and exhaust gas counterpressure.

In case of large deviations from the standard values the diesel engine lose power. To guarantee proper function and full power of the engine, it is vital that the the engine compartment inlet and outlet air ducts are designed large enough to provide adequate flow and functionality.

Two main demands are to be fulfilled:

1. Sufficient supply of air (oxygen) to the engines, in order to ensure a fuel combustion without residues.
2. Ventilation of the engine compartment to keep the temperature level in the compartment low.

Adequate ventilation also improves the operating conditions for the entire electrical equipment of the engine.



#### **CAUTION**

If people are in the engine compartment, the ventilation is to be adapted.

Local safety rules and legal regulations are to be followed.

---

Satisfactory function of air inlets and air outlets must also be guaranteed during bad weather conditions. They should have water guards, and normally sound insulation.



#### **CAUTION**

If the distance between inlet and outlet is too short, the air may circulate which results in a bad ventilation effect.

---

### 11.2 Design requirements

It is of great advantage to consider the supply- and exhaust air ducts during construction and to include them in the hull or superstructure, thus avoiding exposed pipes.

To supply the engine with sufficient combustion air is relatively easy but it is much more difficult to carry off the radiation heat.

On its own, the engine is very effective at pulling in air. It will draw in the required air volume from wherever possible. If the dimensions of the engine compartment inlet and/or outlet air ducts are too small, the engine will draw in both the fresh supply air as well as the hot engine compartment exhaust air. Without the proper ventilation, high temperatures will occur in the engine compartment.

Most of the engine's radiation heat is to be rejected from the engine compartment.

**This is an imperative requirement for keeping the engine temperature under the max. limiting value.**

Air inlet and outlet ducts are to be dimensioned spaciouly in order to achieve a very low velocity of airflow.

**Run the engine compartment inlet ducting** up to the intake air filter of the engine, but maintain a lateral distance of 8 - 12" (20 - 30 cm), to absolutely avoid any entering of water into the engine.

**Air inlets and air outlets must never be installed in the stern transom.** In this area the air is mixed with water and exhaust gases and, therefore, must never be inducted into the boat.

For diesel engines, the air supply pipes should end at a low level in the engine compartment, but not too low to cause a fluidity stop (brackish water) which chokes the air supply. Exhaust air pipes are to be provided diagonally on the opposite side of the engine.

### 11.3 Temperature requirements

Indicated engine power is based on an air temperature of + 25 °C, an atmospheric pressure of 997 mbar, a relative atmospheric moisture of 30 %, a fuel temperature of + 20 °C and a sea water temperature of + 25 °C (according to test standards).

Pay particular attention to good air supply and ventilation, to achieve high engine power and long engine life. Max. temperature for areas where electric components are installed is 85 °C (valid for starter, alternator, ECU, etc., however special regulations (manufacturer specifications) are to be applied).

## 11.4 Calculation of air quantity, ventilation and fan-blast

Min. requirement for proper ventilation and air supply for "pleasure" boats are 4 pipes:

- Two pipes for engine supply air
- One pipe for ventilation of engine compartment
- One pipe, equipped with a fan (efficiency 440 ft<sup>3</sup>/min / 11 m<sup>3</sup>/min.), for exhaust air of engine compartment.

### Air quantity

The engine needs a certain quantity of air for the combustion process, which requires a certain min. flow area for the air stream.

This area may be calculated with the following formula:

$$A = 1.9 \times \text{engine power in kW (Diesel engines)} = \text{cross section of area in cm}^2$$

For example:

$$186 \text{ marine } A = 1.9 \times 129 \text{ kW} = 38 \text{ inch}^2 (245.1 \text{ cm}^2) = 6.96 \text{ " (176.7 mm diameter)}$$

Engine Type	Air mass flow @ rated power (kg/h)	[kW]	Cross section [cm <sup>2</sup> ]	Equivalent diameter [mm]
6 cyl.	SE126E32	645	88	145.9
	SE156E34	790	113	165.3
	SE186E38	910	129	176.7
6 cyl.	SE236E40	995	170	202.8
	SE236S36	850	170	202.8
	SE266E40	1030	190	214.4
	SE266S36	910	190	214.4
	SE286E40	1090	205	222.7
	SE306J38	1085	215	228.1
4 cyl.	SE144E38	580	106	160.1
	SE164E40	668	118	169.0

The values are based on free influx and a pipe length up to 3 feet (one meter) with a max. bend of 90 °. When using longer pipes or several pipe bends, correct the cross section by multiplication with a coefficient (see chart).

Number of bents	Length of pipe in meters/yard				
	1	2	3	4	5
1	1	1.04	1.09	1.13	1.20
2	1.39	1.41	1.43	1.45	1.49
3	-	1.70	1.72	1.74	1.78

## Air intake and Ventilation

---

### Ventilation

The supply and exhaust air pipe should be of the same size, to achieve a low velocity of flow and thus a low sound level.

Pipe cross section for supply and exhaust air is computed with the following formula:

$$A = 1.65 \times \text{engine power in kW} = \text{cross section of area in cm}^2$$

**For example:**

$$186 \text{ marine } A = 1.65 \times 129 = 33 \text{ inch}^2 (212.9 \text{ cm}^2) = 6.48" (16.46 \text{ cm}) \text{ diameter}$$

### Fan-Blast

To permit an effective ventilation of the engine compartment, which keeps the temperatures low, a suction fan is to be installed in the exhaust air duct.



### CAUTION

Never install the fan in the supply air duct. This would cause an excess pressure in the engine compartment with the risk of gas and air leakage in the other compartments of the boat.

---

The blast is to be provided for the following air volume flow:

$$\text{Air volume flow (m}^3\text{/min)} = 0.07 \times \text{engine power in kW}$$

**For example:**

$$186 \text{ marine } 0.07 \times 129 = \text{approx. } 11.81 \text{ yd}^3\text{/min (9.03 m}^3\text{/min)}$$

Total pressure rise by the blast should be  $\frac{3}{8}$  " wc (10 mm WS) (100 Pa).

Based on these two values, air volume flow and total pressure rise, the blast may be chosen.

## 11.5 Example for air inlet and ventilation

Example for air inlet and ventilation of engine on sport boats and similar applications.

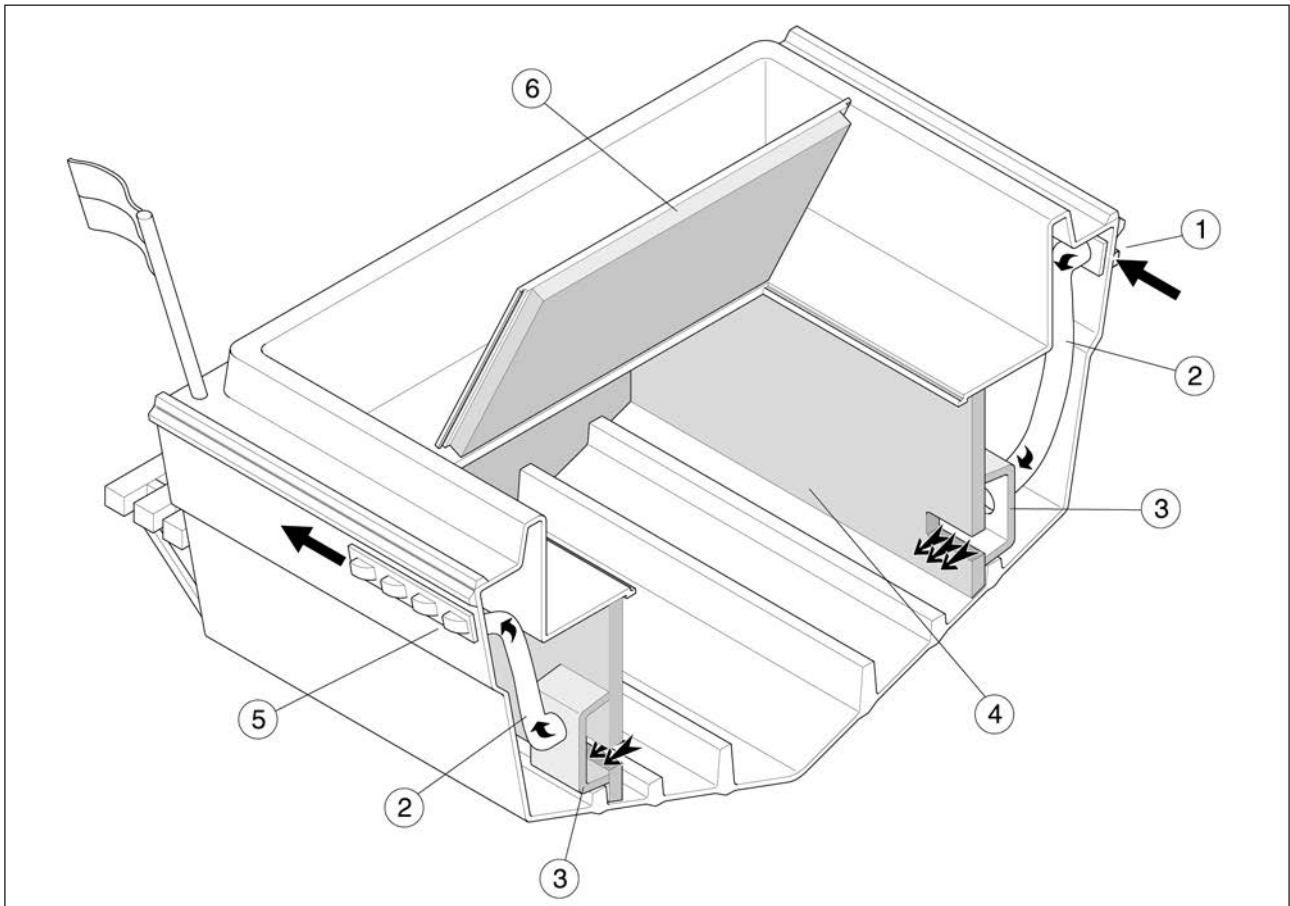

Fig. 143

Pos.	Description	Pos.	Description
1	Air inlet, water separator (effective surface: see chart)	2	Air pipes (dimensions: see chart)
3	Sound absorber (see section "insulation"). In the sound absorber no restriction may occur. Inner distance between walls = pipe diameter	4	Sound-absorbing engine compartment (see section "insulation")
5	Outlet for exhaust air, with inactive engines. For running engines air will be sucked in at 1 and 5. Cross section as for 1.	6	Sound-absorbing hatches



## 12 External consumers

**Steyr Motors** marine engines optionally may be equipped with an auxiliary propulsion at the front end of the crankshaft, see figures below.

Max. decline of output of the auxiliary propulsion is limited however (see chart).

Engine	Outside diameter of belt pulley on crankshaft	Propulsion, max. output
6 cylinder engine	6.5" (165 mm)	65 Nm (18.4 kW) at 2700 rpm.
4 cylinder engine	5.3" (135 mm)	65 Nm (18.4 kW) at 2700 rpm.

### 6 cylinder engine

Auxiliary propulsion at the front end of the crankshaft.

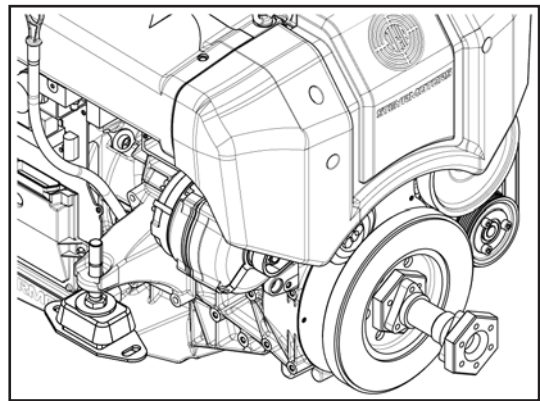

Fig. 144

### 4 cylinder engine

Auxiliary propulsion at the front end of the crankshaft.

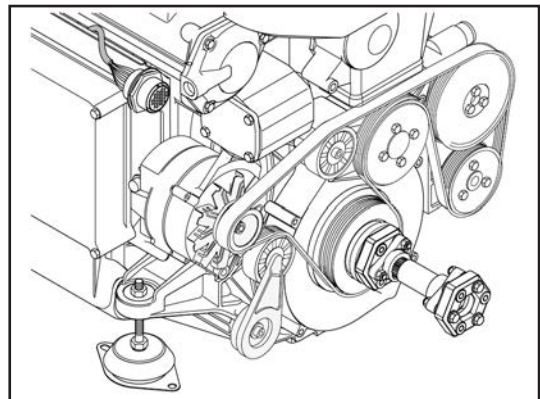

Fig. 145



## 13 Safety instructions

All rotating shafts and belt drives being exposed are to be provided with safety covers. Their construction and size must prevent accidents, e.g. if somebody slips and, in falling, comes close to a source of danger.

To permit an inspection of the engine control, its protection is to be constructed as net or grate. Fix the protection by means of screws and nuts, to allow an easy removal for maintenance.

Example for a belt drive cover.

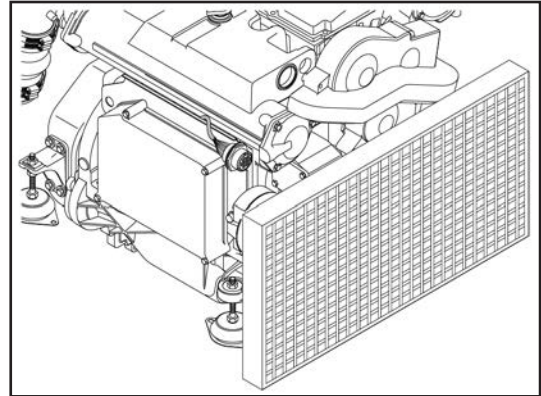

Fig. 146

Example for a stem shaft cover.

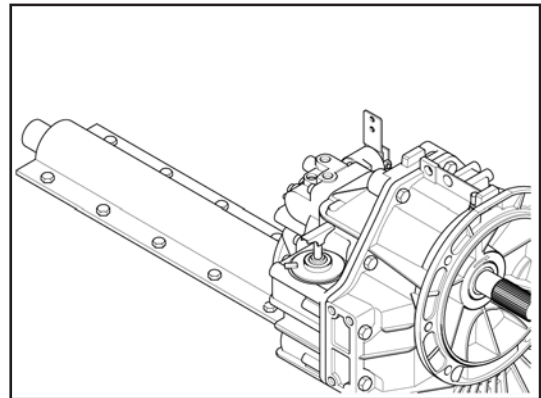

Fig. 147



## 14 Bilge pumps

To achieve max. Lenz power, pumps and piping are to be chosen as follows.

Length of boat (m)	Hand bilge pumps volume flow (m <sup>3</sup> /h)	Power-driven bilge pumps (m <sup>3</sup> /h)	Nominal width of bilge pipes main bilge/branch bilge pipe (mm)	
< 8	3	5	32	
< 10	5	6	32	
< 15	5	7.5	40	
< 20	6	9	50	40
< 24	6	10.5	60	40

Permanent pipe, copper tube  $\frac{3}{8}$  ", outside diameter

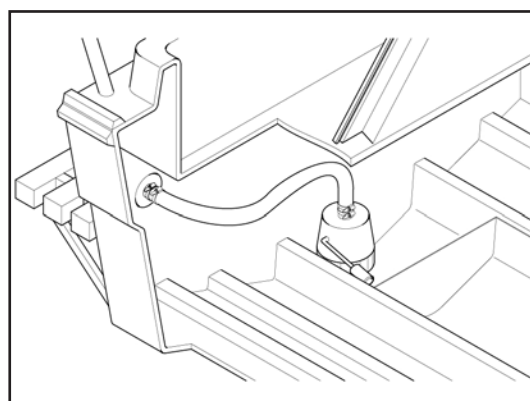

Fig. 148

From the suction side of the pump a copper tube or reinforced rubber hose is to be laid towards the keel. Provide the suction pipe at its lower end with a **relief valve** and a **screen**, the latter to permit easy cleaning. The relief valve prevents a reflux of water of the permanent pipe in case of damage to the pump wheel.

The bilge pump always should have constant water supply, to avoid dry operation. Connect the permanent pipe at the delivery side of the pump. Board lead-in at the delivery side of the bilge pump should be at higher level as the permanent pipe connection.

Equip the permanent pipe with a stop cock. This cock must be closed with inactive engine. Otherwise, sea water may be pressed into the boat through the permanent pipe, passing the bilge pump, unless the suction pipe is provided with an effective relief valve. At the lowest points of the pipes drain cocks are to be installed, so that water can be drained in case of possible frost danger.

To avoid pumping out dirty water in the port or close to the beach, install a cock on the suction pipe of the bilge pump. If drainage is not required, this cock should let air pass onto the pump, thus preventing water to be sucked in from the keel.



## 15 Cabin heating

### 15.1 Separate heating

Heating for the ship's cabin or for passenger rooms may be connected to a separate generating set run by petroleum, diesel, liquid gas etc.

For large heating installations, separate heating is preferred to prevent the operating temperature of the engine from running too low. Such an installation also guarantees a uniform heat input, whether the engine runs or not. Several products are available on the market. For assembly, current safety rules are to be considered.

However, heat can also be taken from the engine's cooling system, and be supplied to a small radiator. But this heat is only available when the engines runs.

### 15.2 Cabin heating, connected to engine

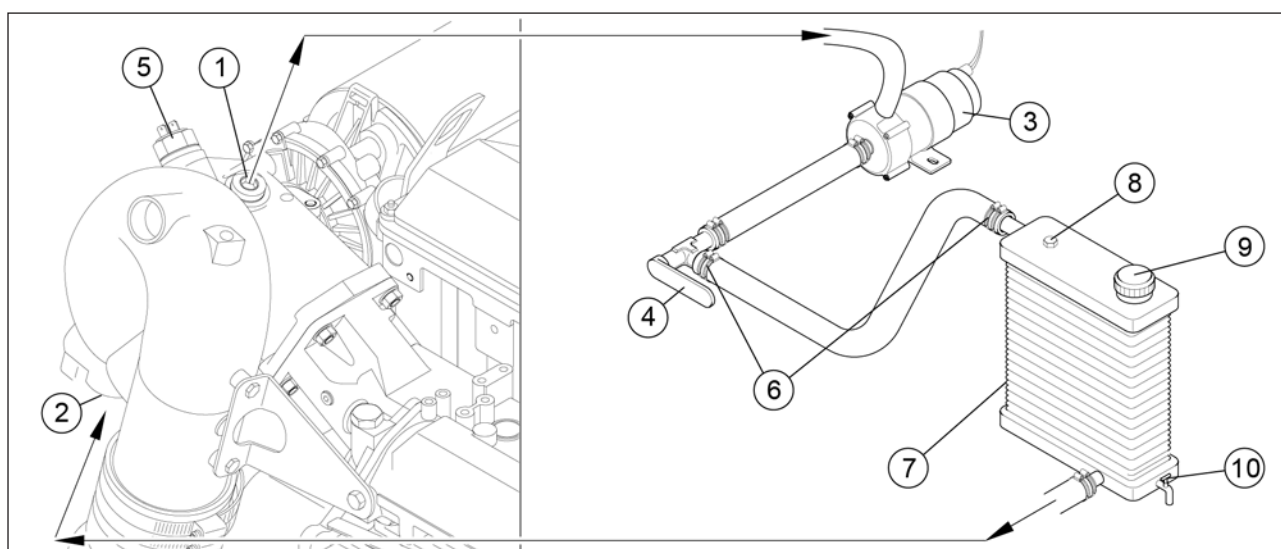

Fig. 149

Pos.	Description	Pos.	Description
1	Hot water outlet from engine	2	Water return to engine
3	Heating pump (Steyr option)	4	Angle with stopcock
5	Thermal-lag switch opening temperature 70 - 74 °C	6	Hose with twin hose clips
7	Cabin heating (event. with fan)	8	Venting screw
9	Filler socket	10	Drain cock (at lowest point)

In a Diesel engine 35 to 40 % of the energy supplied by the fuel are used as motive power. The rest fades as exhaust heat, frictional losses, radiation and through the cooling system.

The heat passing off the cooling system may be used to some extent to heat the cabin. In such case, it is extremely important that not too much heat is taken, which causes the engine to run at too low operating temperature. A quick rise of the engine temperature to operating temperature is also important. If the engine operates too cold (below 65 °C approximately) wear will increase considerably.

## Cabin Heating

---

When the heating demand is too great and/or heating is initiated before the engine reaches operating temperature, severe damage to the engine may result.

It is recommended to install, in the feed line to the radiator, a thermostat with the same or about 2 ° lower opening temperature as the engine thermostat. A circulating pump may also be required.

This maintains the operating temperature of the engine at normal speed and keeps it at the correct level. At the same time, the radiator gets maximum heat.

Never run the engine at idle just to heat the cabin.

Design the pipes for the heating. If one of the radiators is situated higher than the engine, separate compensating tanks are to be installed. The compensating tank should be higher than the radiator, but the maximum height over the engine must not exceed 2 m.



### CAUTION

When installing a separate compensating tank for the engine's cooling system, this tank should be the highest part of the cooling system.

---

The heating inlet and outlet connections on the engine must be provided with stop-cocks in order to permit a disconnection of the heating if required.

Provide the heating installation with drain cocks at the lowest points and with relief cocks at the highest points.

For connecting the water pipes to the engines, bores are provided (ex works equipped with paddings). The arrows on the illustrations show the direction of the water flow.

## **16 Noise attenuation**

### **16.1 General**

In most cases a low noise level is required, which implies an insulation of the machine unit. The disturbing engine noise is transmitted through the hull (i.e. engine base and body) and by the air.

To avoid a propagation of the engine noise through the hull, as a first step, engine and reversing gear are to be provided with elastic suspensions and an elastic propeller shaft coupling (see chapter 3) which results in a reduction of the hull-latent noise.

In addition, the acoustic source is to be shielded as much as possible, to reduce the air-latent noise. This measure, above all, is a very simple way to reduce the high-frequency noise. However, a small opening in the shielding may cause a considerable noise leakage. Therefore, insulating material should also be provided below the engine bed, down to the hull, and all inlets are to be sealed with rubber bellows.

### 16.2 Noise reduction

Equip the unit with noise insulation to keep the sound level as low as possible. Provide noise catchers in the engine compartment. Various type are available.

If a water drain is not possible, the air tubes may be bent like a gooseneck (*Fig. 151*) to avoid the entering of water.

Design of the engine compartment should consider enough space for maintenance of the engine. In addition, the thickness of the noise-absorbing material is to be considered.

The illustration beside shows a construction with a water drain.

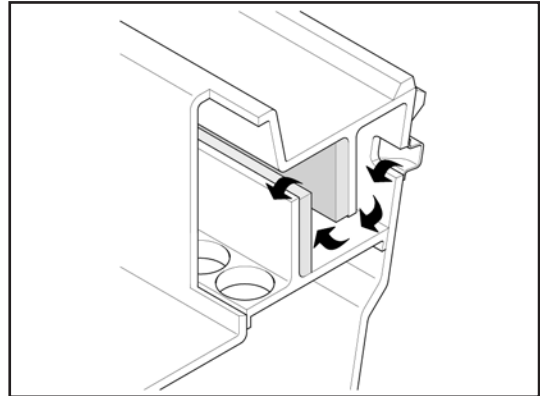

Fig. 150

The illustration beside shows a construction with a gooseneck.

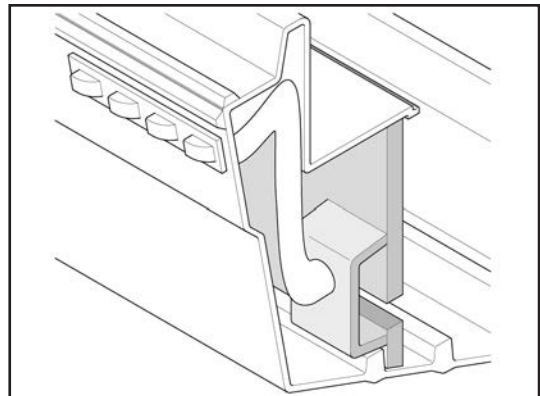

Fig. 151

Carefully shield the acoustic source. Shielding should go down to the hull. Gaps on hatches and bench covers are to be sealed with insulating material (see figure beside). If the engine is under the bottom plate, cover all bulkheads and sheets.

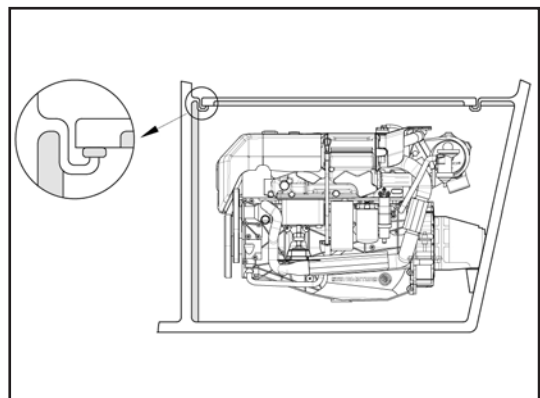

Fig. 152

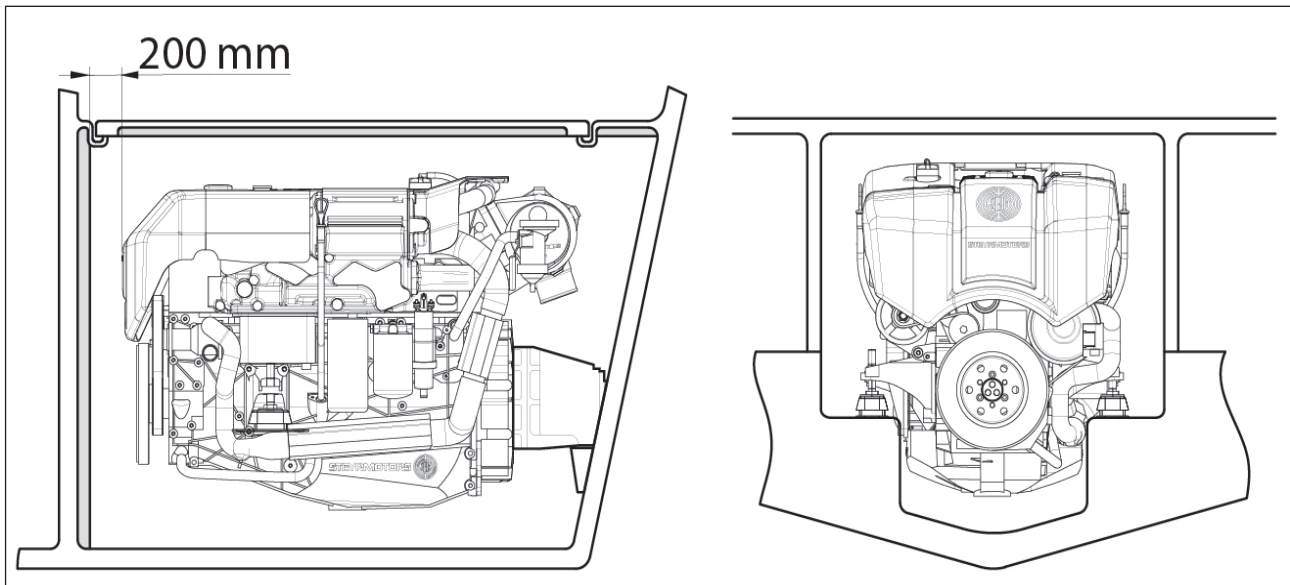

Fig. 153

Before attaching the noise-absorbing material, make sure that there is sufficient space for movements of the engine during operation. Noise-absorbing material is available in different types and thicknesses.

Provide a free space of 8" (200 mm) (see figure above) in front of the engine, to permit its dismantling.

### 16.3 Noise absorbing hoods as superstructure

On small commodity boats and normally on all sport boats, the engine and reversing gear are provided with an elastic suspension (see chapter 7, Engine installation). However, in the case of an elastic stem tube or stem tube bushing, no elastic shaft coupling may be mounted.

It is preferable to construct the engine compartment as a self-contained unit, with a hinged cover (see *Fig. 152*).



#### NOTICE

Always consider enough space for maintenance of the engine - see respective operating instructions.

---

The engine protection is made of 1/12" (2 mm) steel plate or 3/4" (19 mm) plywood. A 3/8" (10 mm) rubber strip is used as cover sealing.

For ventilation of the engine, provide two air intakes (see chapter 7 Engine installation) for sufficient air supply. Connecting the air intakes to the bottom of the engine compartment by means of rubber hoses, ensures sufficient noise reduction without the need for further measures.

Exhaust air of the engine compartment is conducted via two noise catchers with the same cross section as that of the air intakes. These noise catchers must be insulated on both sides with the same material used for the inner side of the engine protection.

In hot regions it may be necessary to install fans (see chapter 7.8, Propeller shaft flange) for air exhaust.

The maximum allowable temperature of the engine compartment is 40 - 45 °C. However, a temperature as low as possible should be the aim.

### 16.4 Noise-absorbing material

One single layer of a flame-proof insulating mat (e.g. "Porolon", "Revertex Acoustics" or "Baryfoil") may be glued directly onto the inner side of the engine protection. This noise absorbing material will in many cases be sufficient. Use contact glue.

Such material requires little space and is easy to handle. All surfaces to be glued must be completely grease and moisture-free to achieve and maintain good adherence.

Many different noise-absorbing materials are available on the market, but only materials meeting the current requirements as to fire protection and noise reduction may be used.

Finished noise-absorbing mats with absorbing layers for soundproofing are also available on the market.

## 17 Control station

### 17.1 General

The design of the control station should enable a functional placement of operating elements, boat control, instruments, navigation equipment and alarm system. That applies for both single and twin control stations.

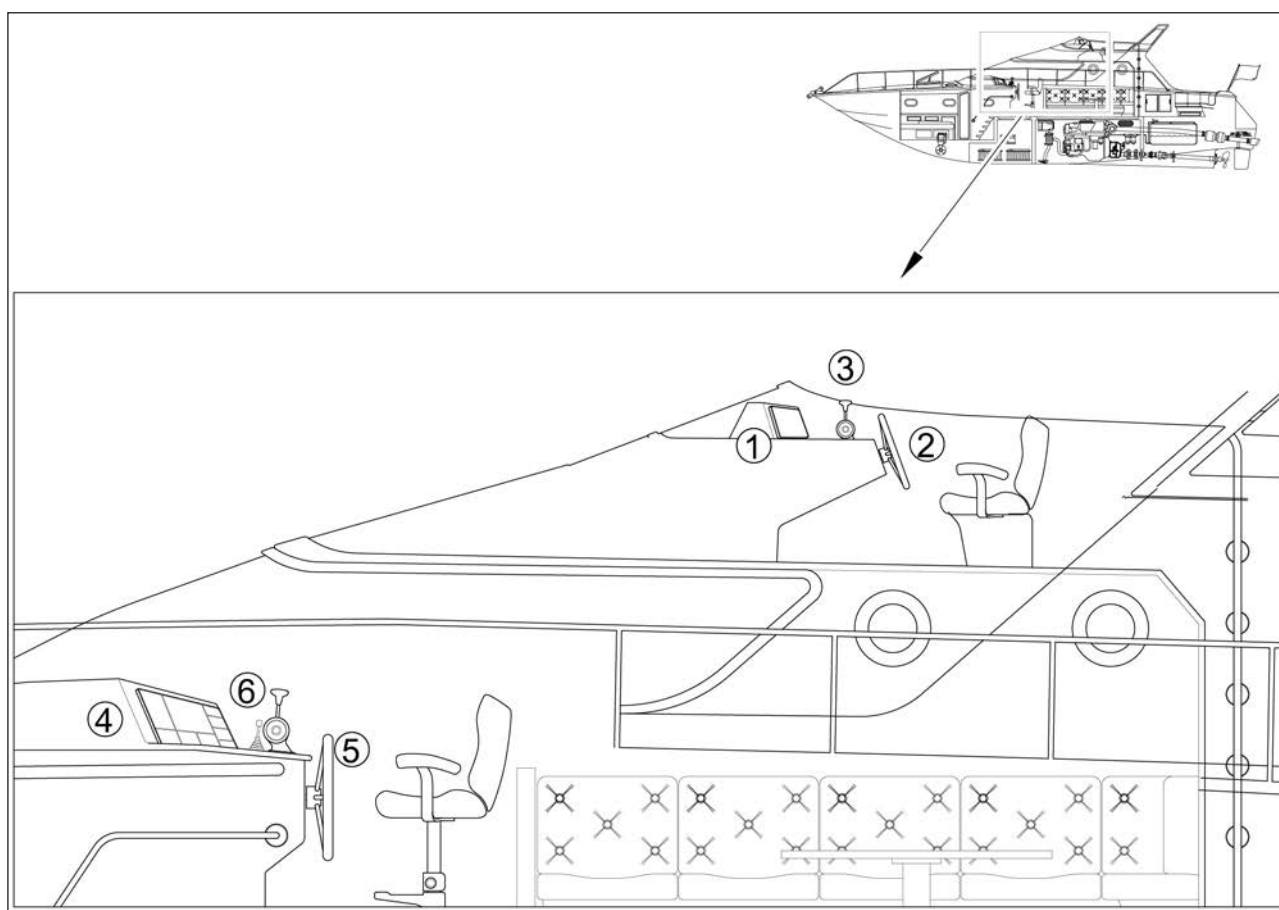

Fig. 154

Pos.	Description	Pos.	Description
1	Instruments - top control station	2	Steering - top control station
3	Control lever - top control station	4	Instruments - lower control station
5	Steering - lower control station	6	Control lever - lower control station

## Control Station

Control stations should also provide a good air circulation to the rear of the instruments as shown.

Negative example – no air circulation at the rear of the instruments.

Item	Description
(A)	Air
(B)	Solid door
(C)	No air circulation
(D)	Console prime for fogging

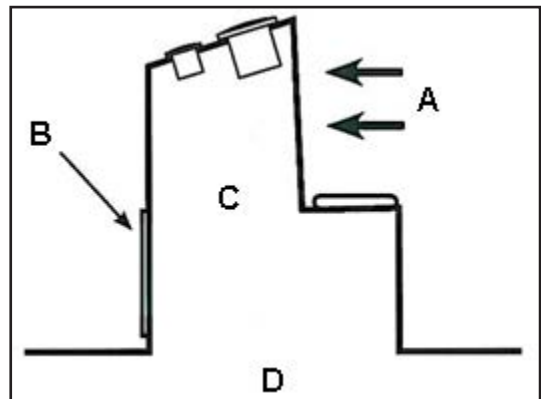

Fig. 155

Positive example – a proper air ventilation on the backside will reduce fogging in instruments.

Item	Description
(A)	Air
(E)	Louvers or Vents
(F)	Good air circulation
(G)	Reduced fogging suggestion

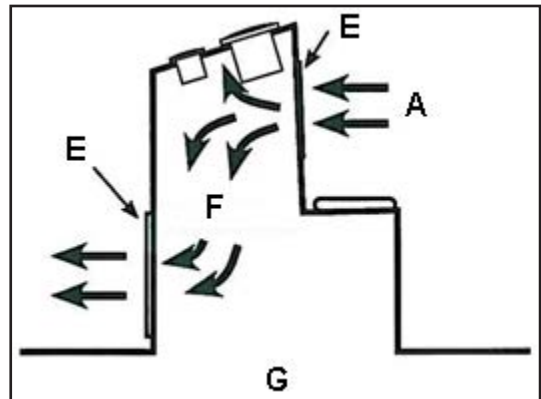

Fig. 156

## 17.2 Control systems

For **Steyr Motors** marine engines, a mechanically operated control is provided. However, other control systems may be used as well.

### 17.2.1 Mechanical control

With mechanical control, movement of the lever is transmitted through a steel cable in a plastic sleeve to the engine and reversing gear. This cable is called a pressure and tension cable.

The figure shows the most current mechanical control with a combined lever for accelerator potentiometer (acceleration) and reversing gear (forward or backward). For special applications (e.g. industrial use), control of accelerator potentiometer and reversing gear may be divided between two dedicated levers.

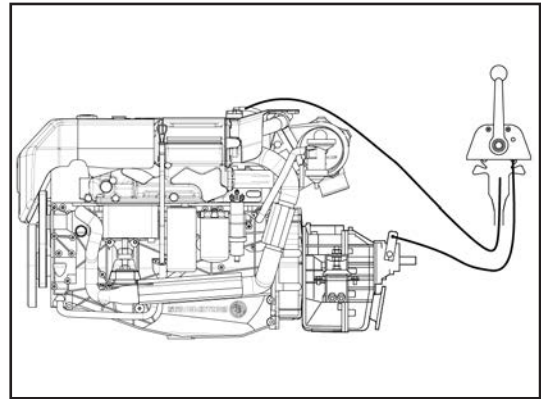

Fig. 157

### 17.2.2 Hydraulic control

Hydraulic control is designed for ships where the distance between the engine and control station is too great and pressure and tension cables often cause undesired play.

In this case, control is done by means of hydraulic cylinders triggered by individual control valves. These control valves receive the control commands via the hydraulic liquid of the control levers. A separate hydraulic tank is to be installed.

Quality of the hydraulic liquid requires special attention since only liquids with a low modulus of extension and a very low viscosity may be used.

In no case may the hydraulic liquid be merged with different quality liquids.

### 17.2.3 Electronic control

With electronic control, movements of the control lever are converted into electric signals. In this case, the microprocessor unit plays a central role. It is attached as close as possible to the engine and controls via short tension and pressure cables the engine and the reversing gear.

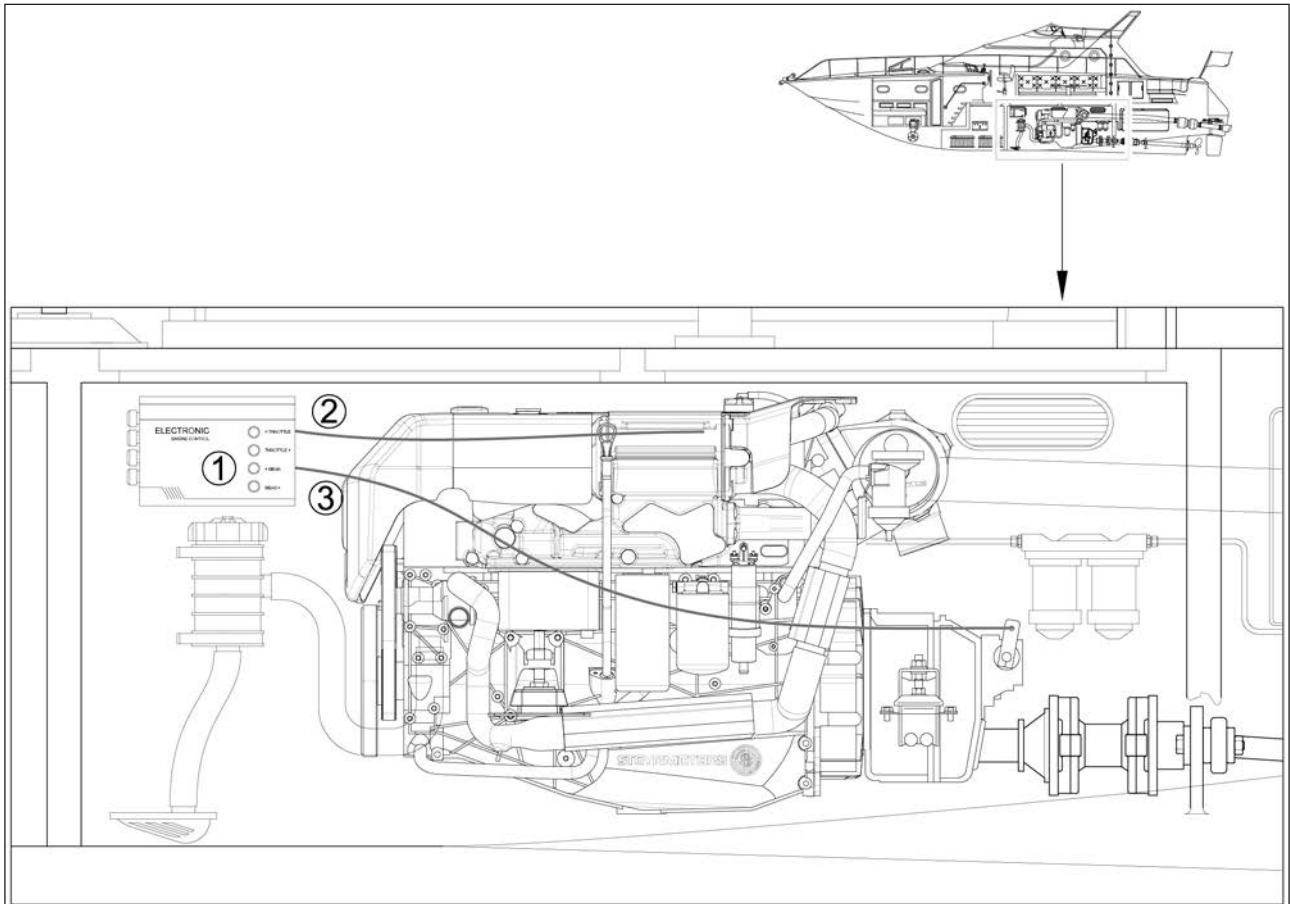

Fig. 158

Pos.	Description	Pos.	Description
1	Microprocessor unit	2	Tension and pressure cable accelerator
3	Tension and pressure cable reversing gear		

A potentiometer on the control handle imparts the respective position of the handle to the microprocessor unit. In the processor unit this signal is converted via servo-motors into mechanical movements.

Depending on the manufacturer and design of this processor unit several control levers may be connected. For the control of twin engines two processor units are required. Compared to mechanical control, mechanical differential devices are not necessary.

Scheme of an installation with one engine and one control station:

- (1) One single-lever control
- (2) Microprocessor unit
- (3) Tension and pressure cable accelerator
- (4) Tension and pressure cable reversing gear

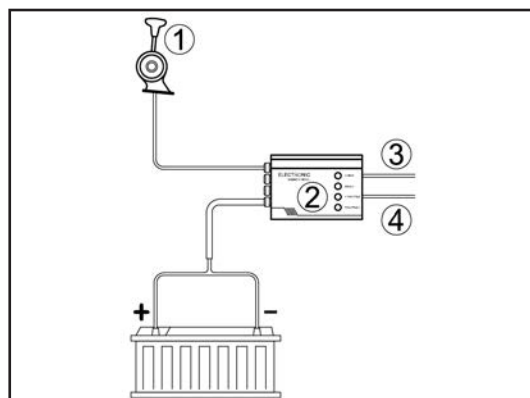

Fig. 159

Scheme of an installation with one engine and two control stations:

- (1) Two single-lever controls
- (2) Microprocessor unit
- (3) Tension and pressure cable accelerator
- (4) Tension and pressure cable reversing gear

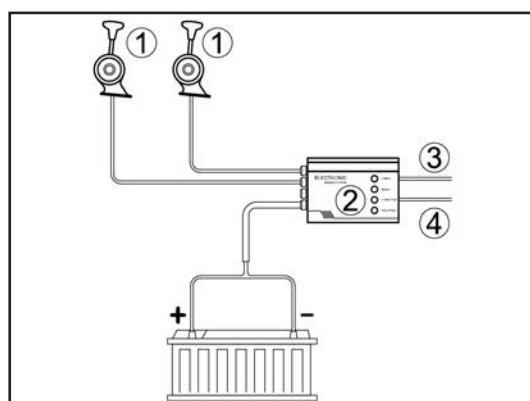

Fig. 160

Scheme of an installation with two engines and two control stations:

- (1) Four single-lever controls
- (2) Two microprocessor units
- (3) Tension and pressure cable accelerator
- (4) Tension and pressure cable reversing gear

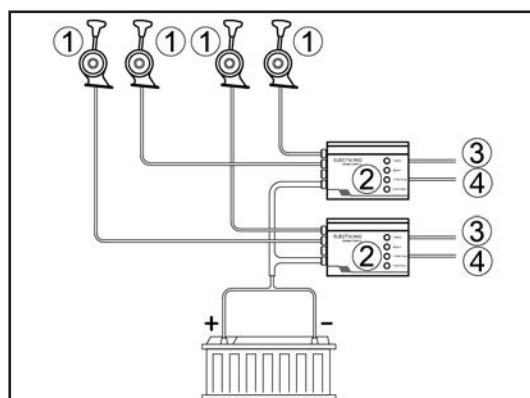

Fig. 161

### 17.3 Control levers

Speed and control levers should be of good quality to ensure a reliable control of the boat. For hydraulic reversing gears we recommend the combined lever control for single and twin engines. This control is designed in such a way that control of engine speed and hydraulically actuated reversing gear can be done by one single lever.

If the engine is equipped with a clutch for mechanical operation, the engine speed is to be controlled by means of a separate gearshift.

---

#### **NOTICE**

When engaging reversing gears or clutches, the engine speed never should exceed 800 rpm.

---

#### 17.3.1 Kinds of control levers

- (1) Single-lever control, for top assembly
- (2) Single-lever control for twin-engine plant, for top assembly
- (3) Single-lever control for lateral assembly
- (4) Twin-lever control for top assembly

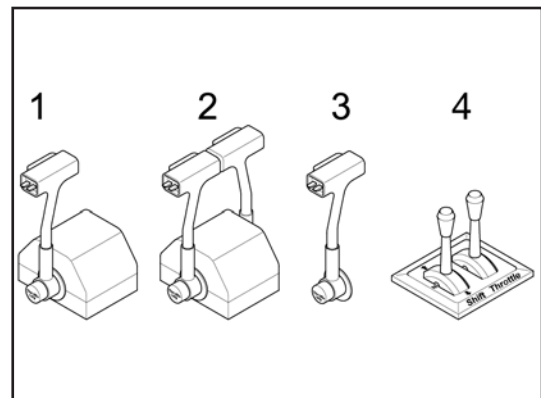

Fig. 162

#### 17.3.2 Possible functions of control lever

- (1) Safety key: only by pressing key 1, control lever may be moved forward or backward.
- (2) Trimming switch
- (3) By pressing key 3, engine speed may be changed without putting in a gear

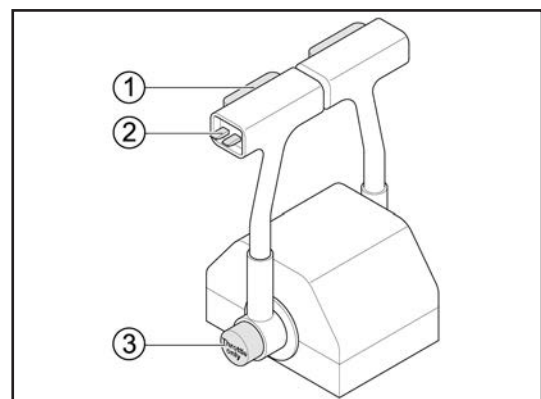

Fig. 163

## 17.4 Control cable

Cables provided for the control devices described are designed for function in two operating directions (push-pull function) and available in many different lengths. Cables should not be shortened or extended respectively connected piece by piece.

Cables for reversing gear and engine normally have different lengths. These lengths are to be considered and/or measured exactly when planning the cable run. The cables must be laid unrestricted and only be clipped at the spots provided. If necessary, cables may be laid in cable-protection pipes.

The speed cable must not be clipped closer than 0.9 m to the control, since this cable moves back and forth slightly during operation.

The speed and reversing gear cables are to be laid minimizing the number of bends but maximizing the bend radius in order to avoid unnecessary friction and clearance losses. Min. curve radius is 150 mm.

### 17.5 Control stations

For boats with a top control station (fly bridge), the control of engine and gear may be done via an electrically controlled servo unit or a mechanical shift unit. Manoeuvring and control apparatus are installed twice. Conversion of the control levers between the individual control stations may be done automatically if an omnibus implement is provided. The speed cables of the two controls are connected to the actuator solenoid unit.

Automatic commutation of the connecting cables between the control stations, one for every engine, should be placed as close as possible to the reversing gear.

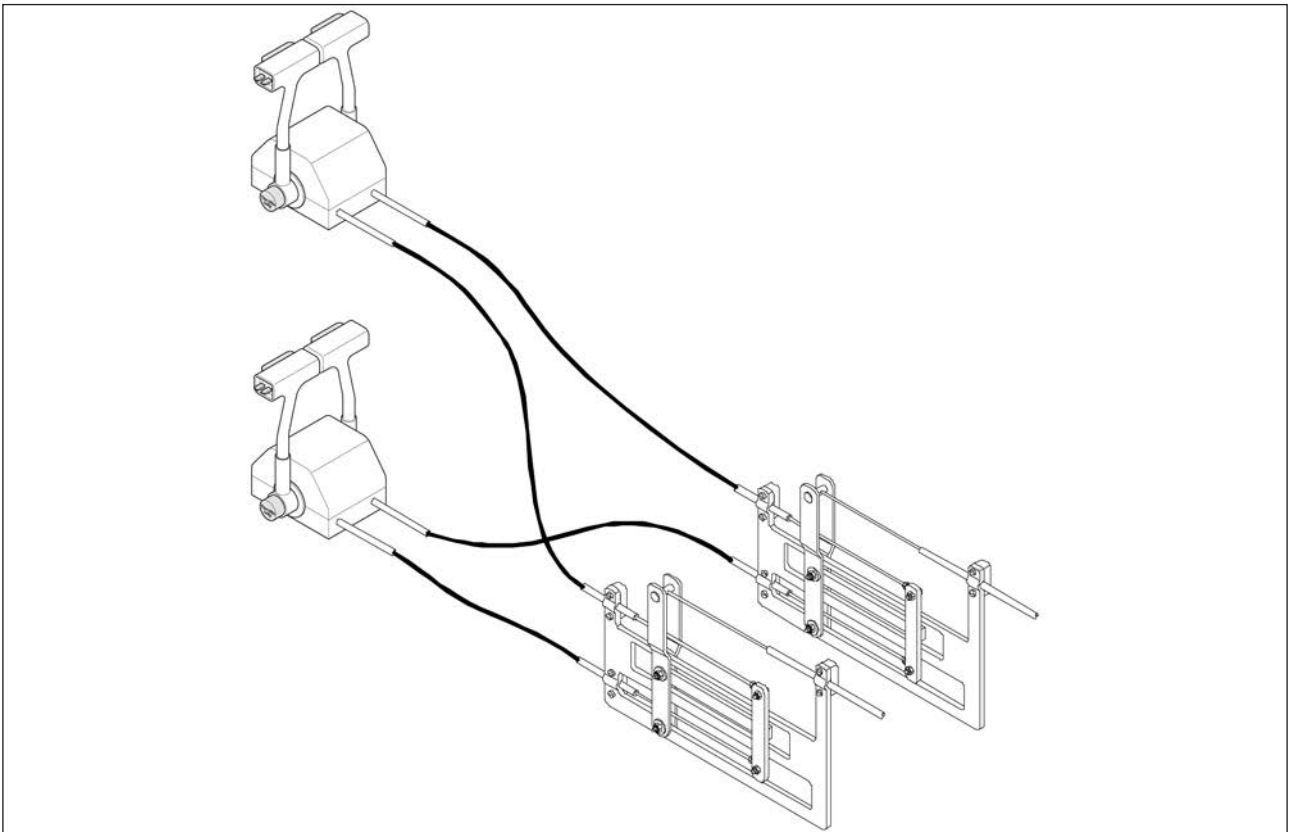

Fig. 164

## 17.6 Instrument panels

### 17.6.1 Scheme for instrument panel and SCC2

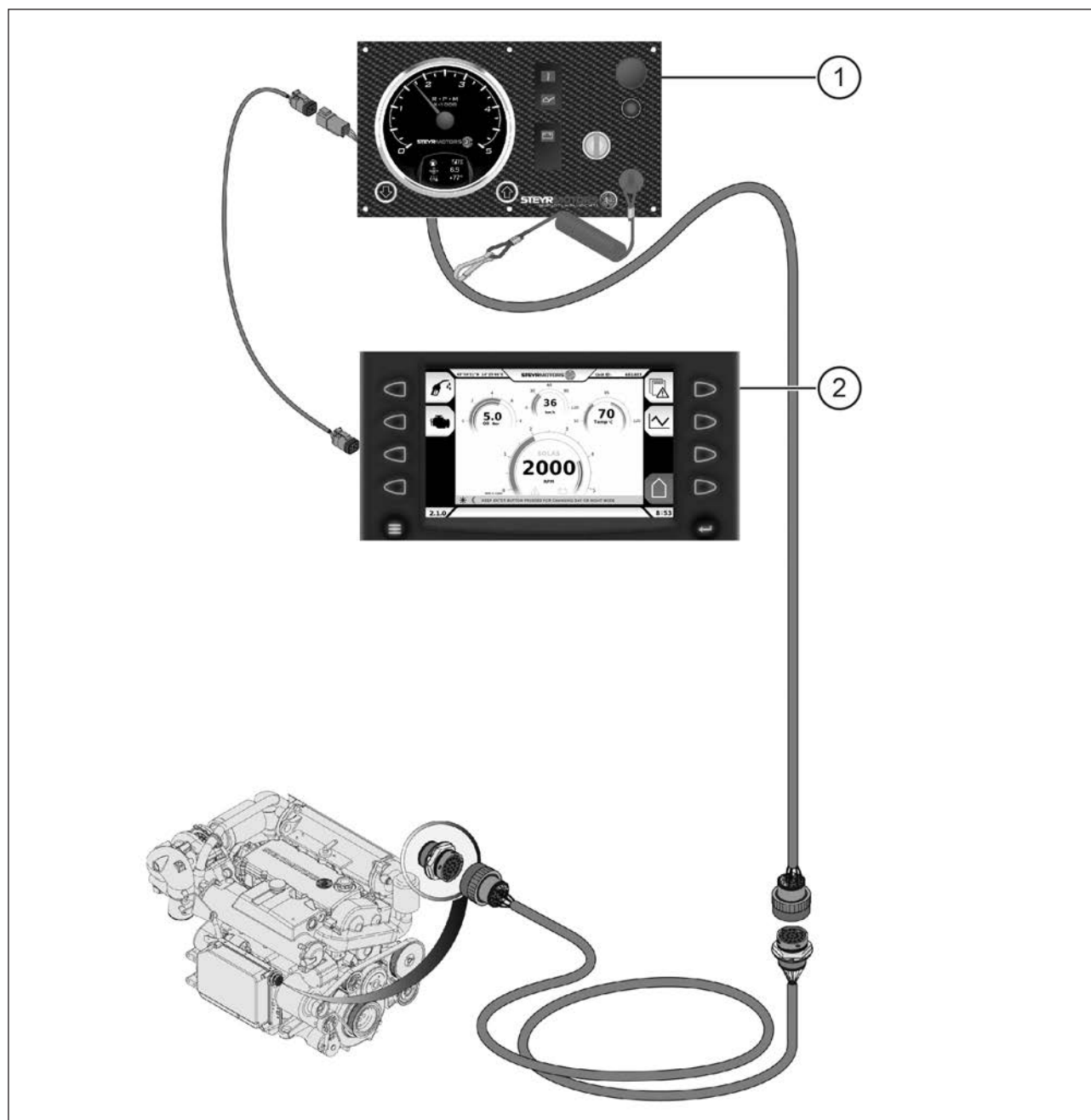

Fig. 165

Pos.	Description	Pos.	Description
1	Standard equipment instrument panel with cable 7 m	2	SCC2

### **NOTICE**

Oil pressure sender for twin installation must be changed.

17.6.2 Scheme for instrument panel and SCC2 with GPS

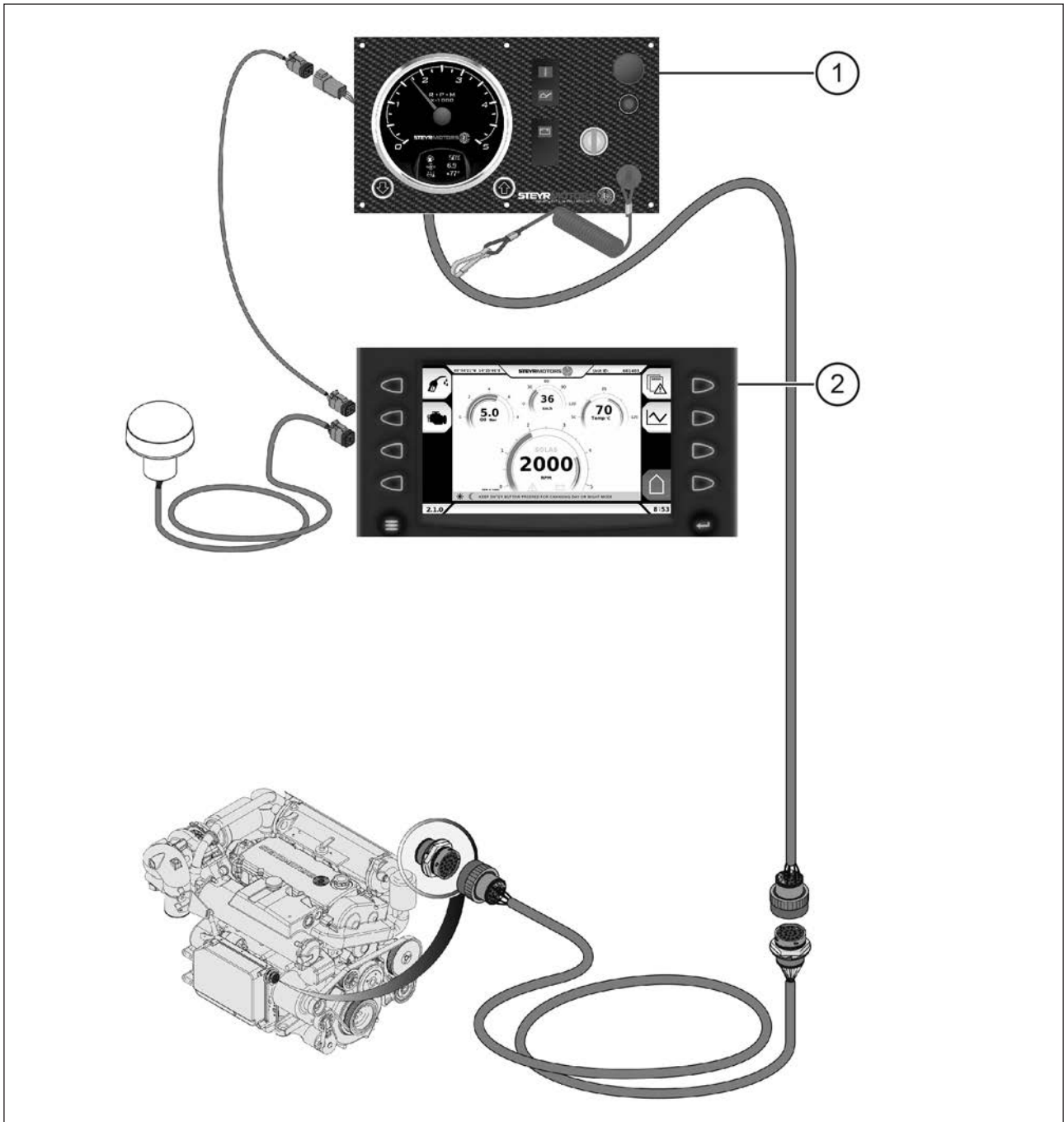

Fig. 166

Pos.	Description	Pos.	Description
1	Standard equipment instrument panel with cable 7 m	2	SCC2

## 17.7 Cut out drawings

---



### CAUTION

These electronic mounting templates are provided for reference purposes only.

Every **Steyr Motors** panel and SCC includes a full-scale cutting template in the box.

When using electronic templates for planning, be certain to compare the printed measurements on the template against an actual ruler or other measuring device.

Some printer drivers will rescale these templates to fit on a single sheet of paper.

For optimum results, **Steyr Motors** recommends printing electronic templates on DIN A4 paper at 100 % scaling.

**Always measure twice, and then cut once!**

---

### 17.7.1 Cut out drawing for instrument panel (standard) / instrument panel SOLAS

Refer to next page.

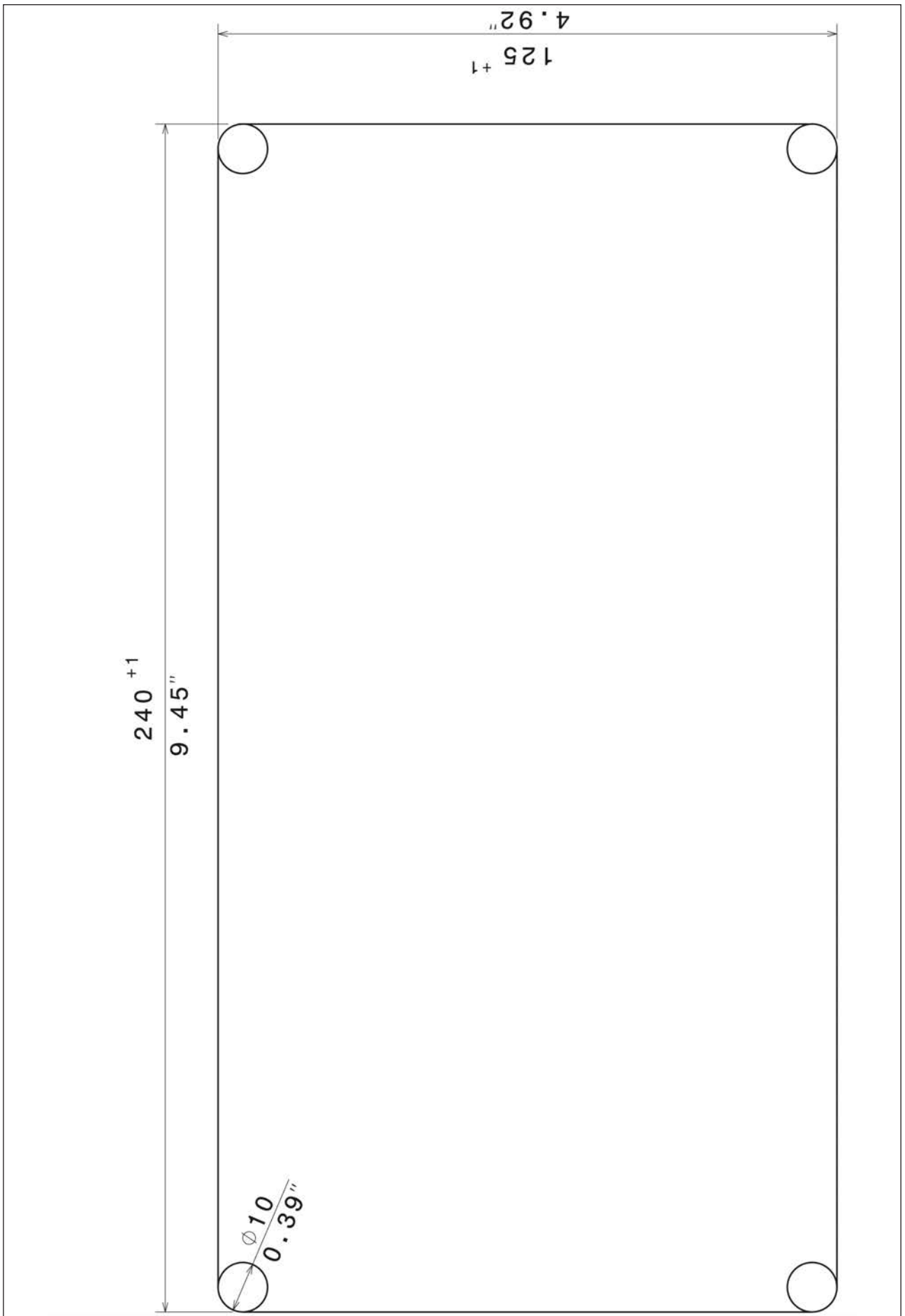

Fig. 167

### 17.7.2 Cut out drawing for SCC key ignition panel/push button ignition panel (SOLAS)

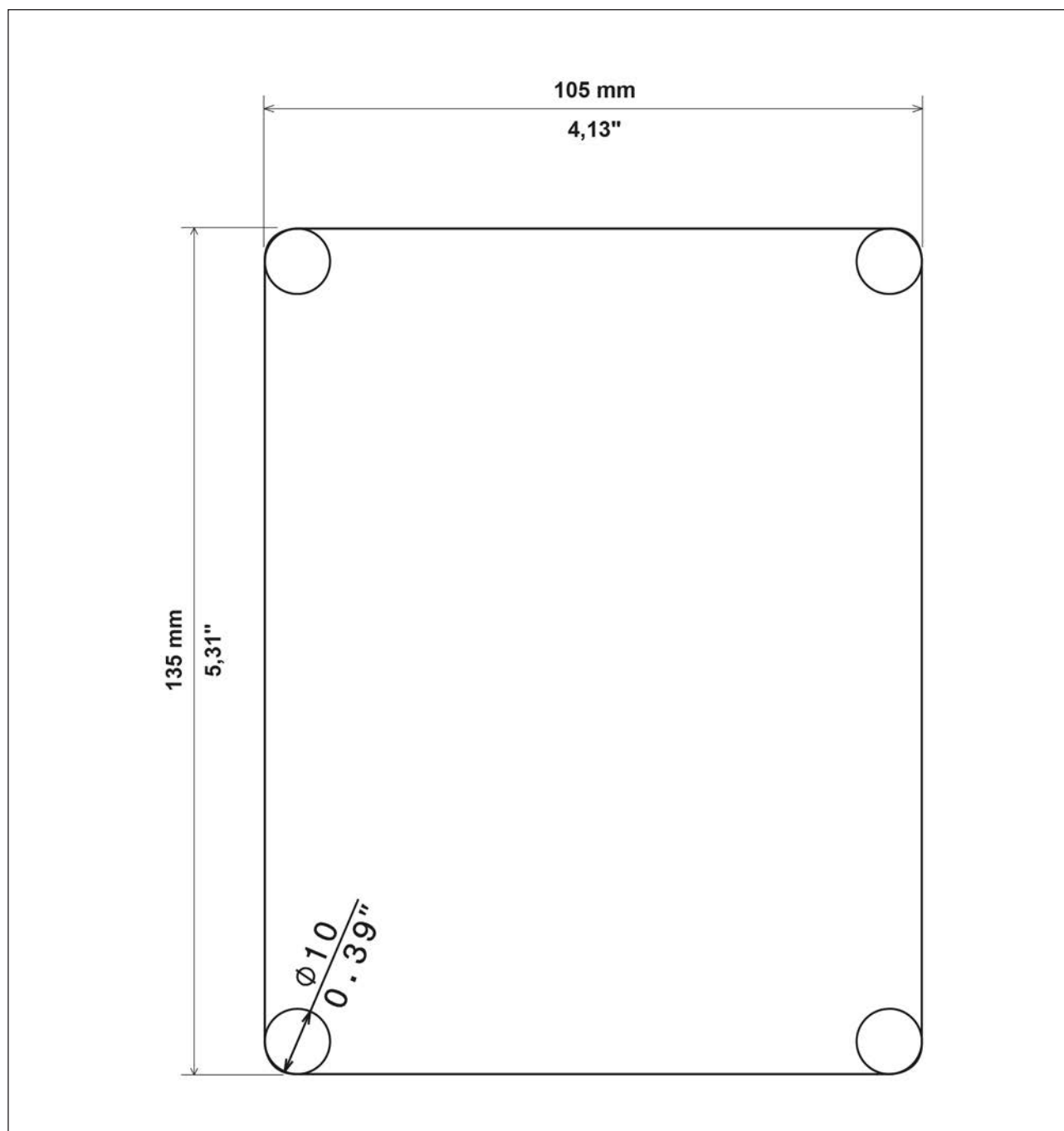

Fig. 168

17.7.3 Cut out drawing for SCC2

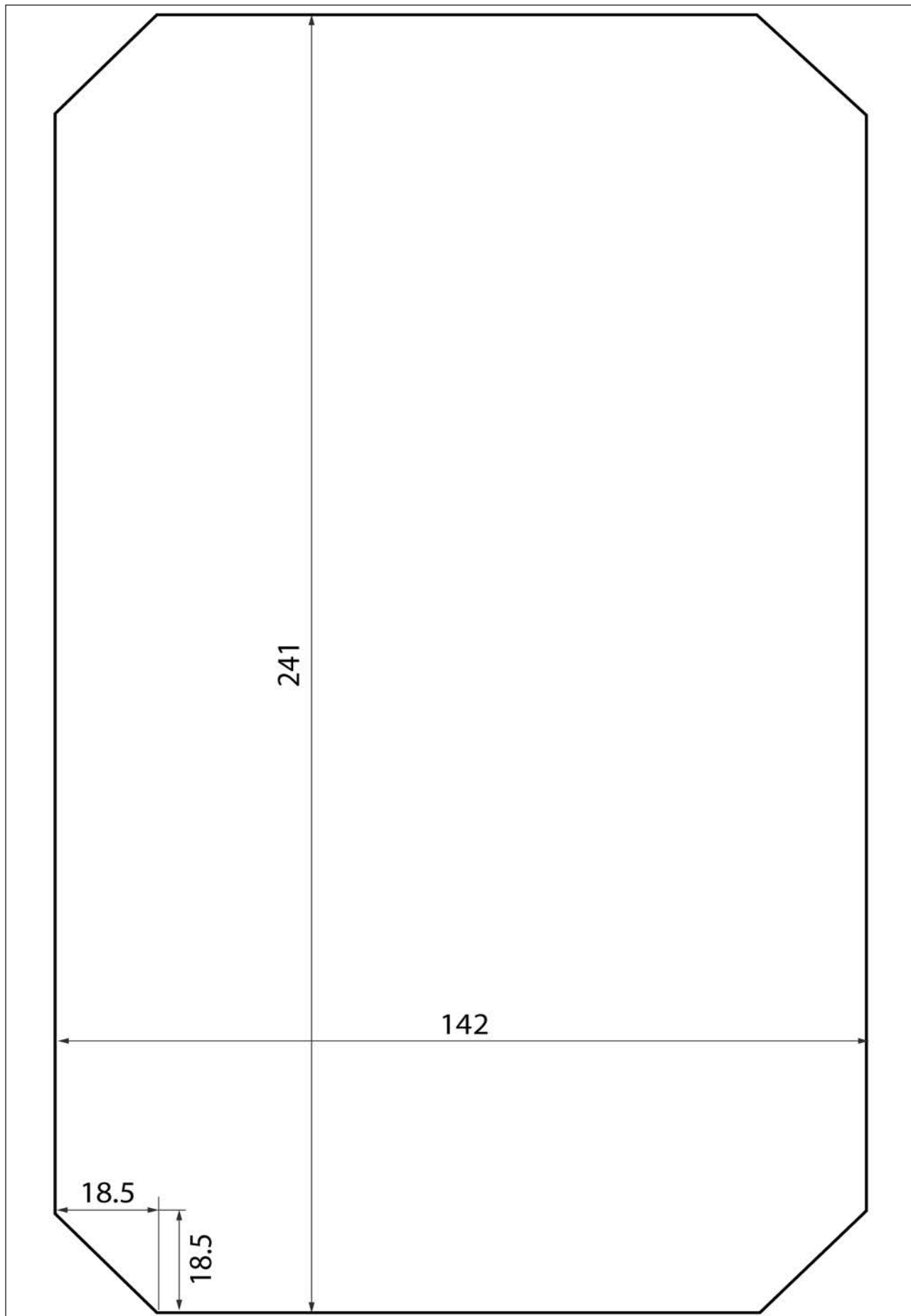

Fig. 169

## 18 Electrical equipment

### 18.1 General

Cable laying is to be planned and carried out precisely and carefully. Cables must be approved for marine operation. Pull the cables through appropriate protective sleeves to be fixed properly. Make sure that cables are not too close to hot parts of the engine. Cables must not be exposed to mechanical wear and mechanical abrasion. If necessary, pull the cables through protection tubes.



#### **CAUTION**

Never fix a cable in such a way that it could lay in bilge water.

Ensure and validate a "common - GND" connection is present between devices using the same CAN-Bus!

---

### 18.2 Batteries

Install the batteries in a battery box situated low in the boat to avoid leaking of battery acid due to motion of the sea. Provide easy access to the box for servicing the batteries, as well as proper ventilation, as the batteries generate small amounts of explosive gas.

Install main switches at the positive side only. In case of one single switch, install it easily accessible at the positive side.

Required capacity of main switch:

- Min. 300 A (short-circuit current)
- Fuse on positive battery terminal 300 A.



#### **CAUTION**

Only bipolar systems may be installed otherwise galvanic streams may occur which cause corrosion.

---

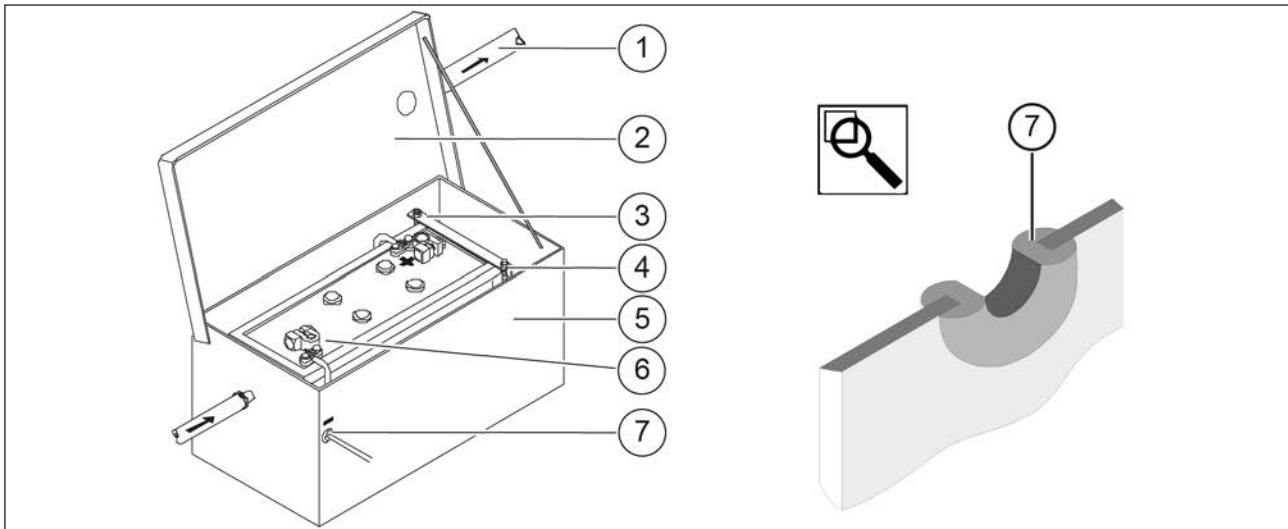

Fig. 170

Pos.	Description	Pos.	Description
1	Air tube, at least 25 mm (1 "), conducted outwards	2	Cover, same material as box
3	Clamping bar, which fixes the battery by securing the nuts (L-iron or flat bar)	4	Studs
5	Box made of steel plate (min. 3 mm) acid-proof	6	Clamps with tightening screws (use pole grease)
7	Rubber sleeves for cable passage		

	6 cylinder engine	4 cylinder engine
Rated capacity:	12 V / 115 Ah	12 V / 92 Ah
for 24 V installation:	2 x 12 V/ 115 AH	
Cold test current:	650 A	450 A

### 18.3 Battery cable lengths and cross-section

Determine the length of the positive cable from the positive pole (+) of the battery to connection no. 30 at the starter.

Total length is the sum of cable length of positive cable (+) and ground cable (-).

Example (4 cylinder engine):

Positive cable = 3.0 m

Ground cable = 2.0 m

Total length = 5.0 m → cable cross section = 70 mm<sup>2</sup>

For ground connection, determine corresponding cross-sections as per chart.

#### For 6 cylinder engines only

Starter motor: 3 kW - 12 V

Battery size: 112 AH

Total length in m	Cable cross-section in mm <sup>2</sup>	AWG
0.0 - 3.0	50	0
3.1 - 4.5	70	00
4.6 - 5.5	95	000

#### For 4 cylinder engines only

Starter motor: 2 kW - 12 V

Battery size: 92 AH

Total length in m	Cable cross-section in mm <sup>2</sup>	AWG
0.0 - 4.0	50	0
4.1 - 5.0	70	00
5.1 - 6.0	95	000

In general, take care that battery cable lengths are kept as short as possible.

### 18.4 Additional current utilization devices

Before connecting an additional current utilization device, such as lighting, radio, echo-sounder etc., first calculate the total power consumption of all these components to guarantee sufficient capacity of the dynamos.

Example: When using a 50 A dynamo you may connect current utilization devices consuming all together 50 A simultaneously. In case of a too small capacity of the dynamo a larger or an additional dynamo may be installed.

Since the starting quality of the battery must be guaranteed, a maximum of 90 % (45 A) of the rated capacity may be consumed simultaneously and permanently.

---

#### **NOTICE**

Electrical equipment of the engine permanently requires approx. 15 A.

---

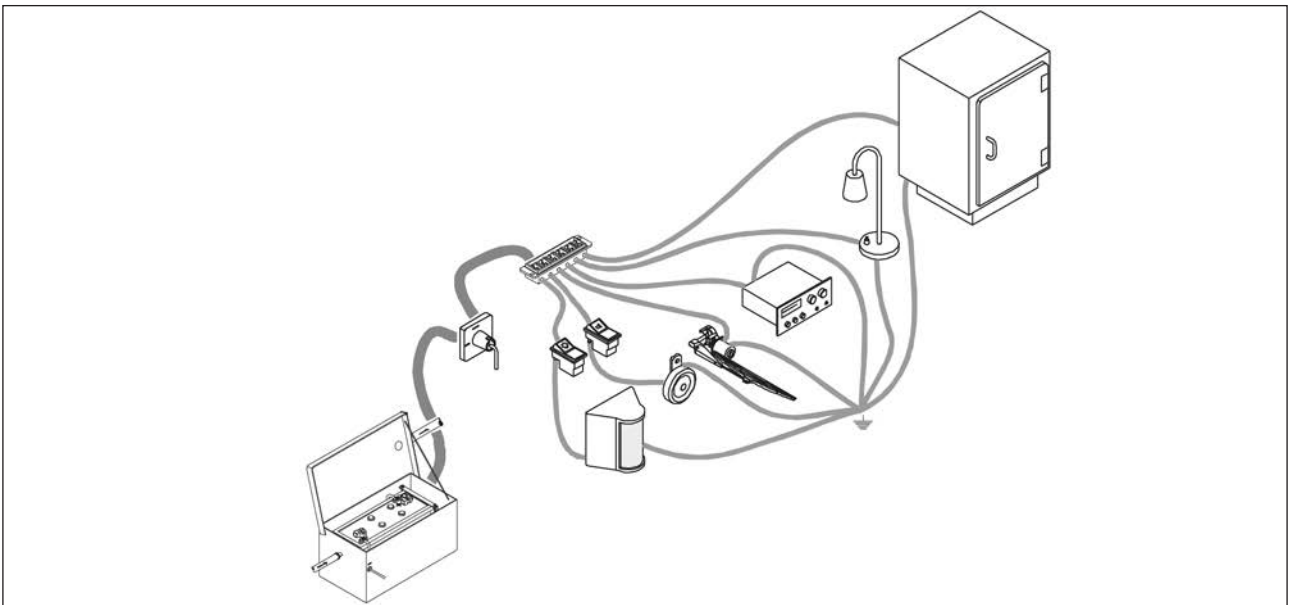

Fig. 171

### 18.5 Calculation of cable cross-section for additional equipment

Use this table to find the cable cross-section required for a specific power requirement.  
 Example: A current-utilization device (24 V) of 300 Watt is to be installed. In this case distance from the current utilization device to the battery is four meters. Required cable length is 8 meters, since cable length back and forth is to be considered. In the table a straight line is drawn from 8 in the length (m) column sloping downwards to 300 in the power column. This straight line crosses the cross-sectional column at 4.5. Therefore, a cable with a cross-section of 4.5 mm<sup>2</sup> min. is to be used. This value is rounded up to the next cable size available.

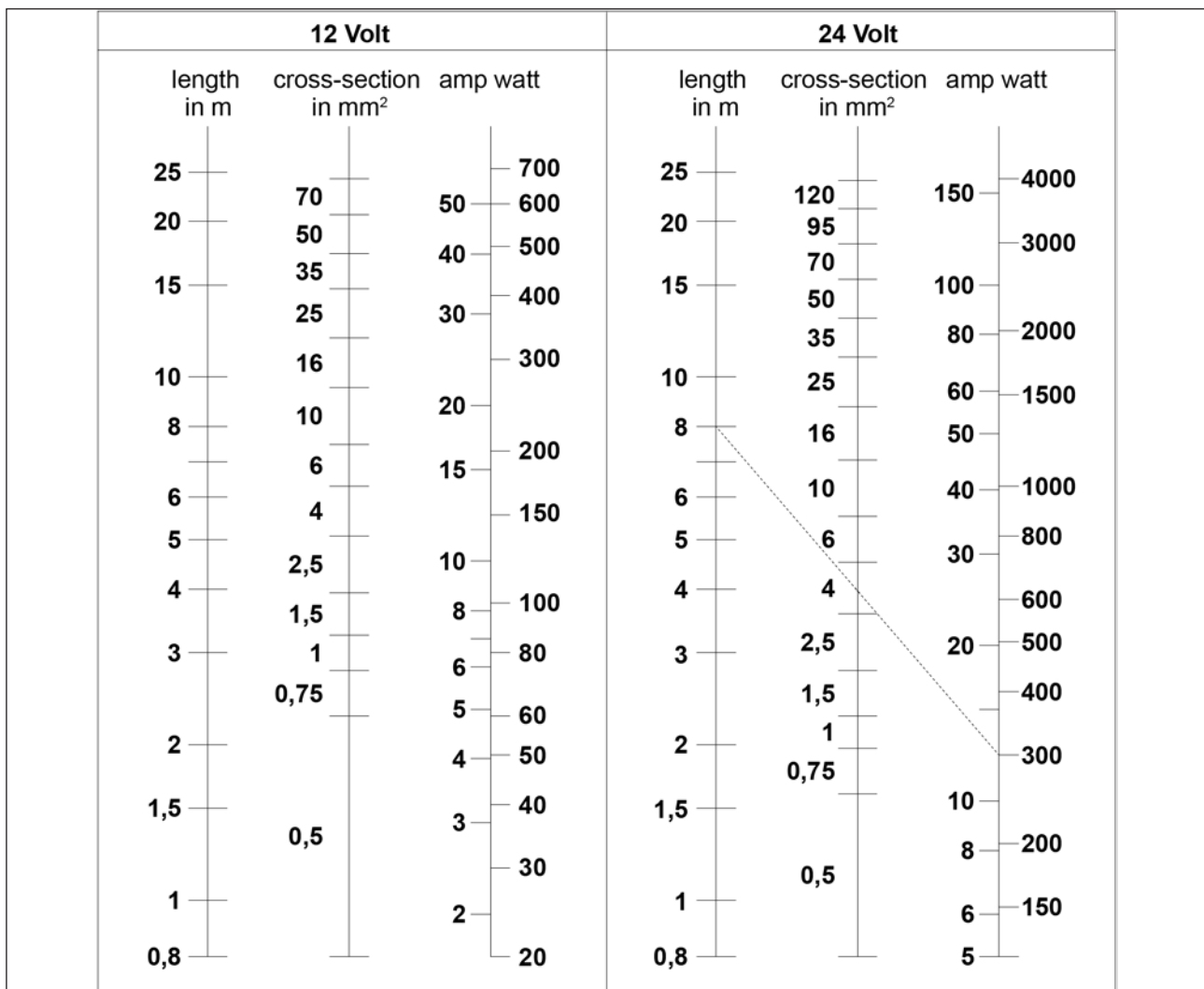

Fig. 172

### 18.6 Cable cross-section

The cable cross-section is determined by the rated current of the fuse.  
 Rule of thumb for dimensioning: a maximum of 10 Amp per mm<sup>2</sup>.



## 19 Commissioning of installation

For commissioning of a new engine, please use the following documents for appropriate hand over to customer and warranty approval by **Steyr Motors**:

1. Template: Commissioning report  
(see [www.steyr-motors.com](http://www.steyr-motors.com))
2. Installation guide  
(see chapter 20 / Appendix)
3. Record a log-file with SMO-EDT program  
For instructions on running the engine during the log file ask **Steyr Motors**  
→ forward filled out documents to: [commissioning@steyr-motors.com](mailto:commissioning@steyr-motors.com)

Any product handed over to an end user must have literature with proper operation instructions for the operator. **Steyr Motors** issues an Operation, maintenance and warranty manual (SMO No.: 707245) that is sent with the product. Inside this manual, instructions are given for a recommended procedure to break-in the engine (see chapter start-up and functions / engine break-in procedure). These instructions are essential for the customer to achieve the best performance from their new product.

However, if this instruction interferes with the need to perform a propeller assessment on a newly built vessel, **Steyr Motors** recommends the following:

**To enable a boat builder or installer to perform the necessary propeller selection test, Steyr Motors permits operating a new engine for a limited time of 5 to 10 minutes during the mentioned engine break-in procedure to the maximum power at rated engine speed.**

This period shall be more than efficient to choose the right propeller and record obtained engine operation parameters.



## 20 Appendix

### 20.1 Drill templates

For drill templates see <https://www.steyr-motors.com>

In case of a missing template please e-mail to [technical@steyr-motors.com](mailto:technical@steyr-motors.com).

## 20.2 Propeller calculation form

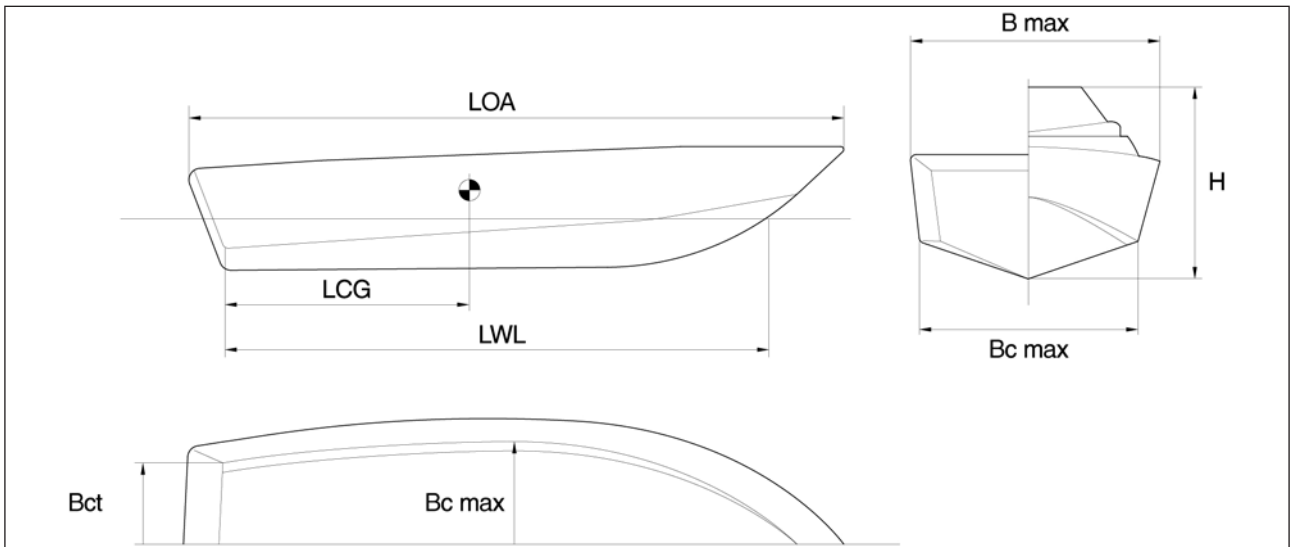

Fig. 173

Manufacturer of boat:	.....		
Boat type:	.....		
Own weight:	W min	.....	kg
Total weight:	W max	.....	kg
Over-all length:	LOA	.....	m
Length of boat, over water line:	LWL	.....	m
Load centre of gravity, endwise (from transom):	LCG	.....	m
Over-all width of boat:	B max	.....	m
Width of boat, at water line:	Bc max	.....	m
Width of boat, at transom:	Bct	.....	m
Over-all height of boat:	H	.....	m
V-angle boat centre:	$\beta$ at	.....	°
V-angle at transom:	$\beta$ t	.....	°
Engine model:	.....		

<b><u>Gear:</u></b>		<b><u>Propeller data:</u></b>	
Gear type	.....	Diameter:	..... inch
Reduction of speed	..... : 1	Pitch:	..... inch
Shaft diameter	..... mm	Number of blades:	.....
Slope of shaft	..... °	Sense of rotation:	.....
Cone	1 : .....	Material:	.....

## 20.3 Installation guide

### 20.3.1 Engine base must

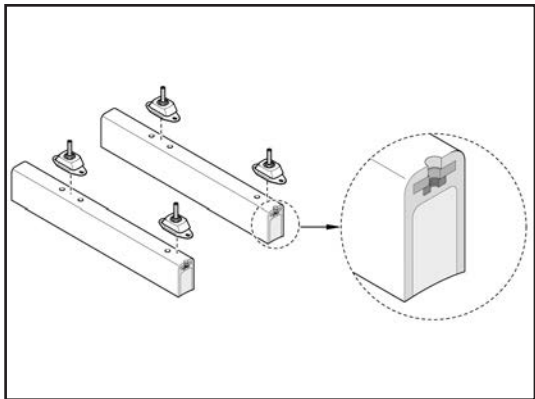
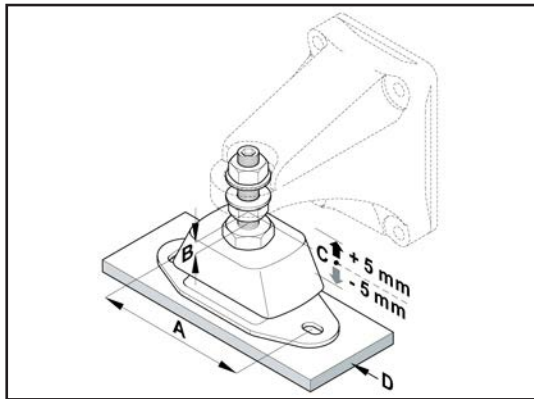
<p><b>1</b></p> <p><b>Engine base must</b></p> <p><b>Distribute the engine weight, be straight, strong, and level.</b></p>  <p>Fig. 174</p> <p><b>Refer to the installation instructions for mounting distances</b></p>	<p><b>Engine mounts</b></p> <p>(A) Bore dim. bearing flange 137.5 mm          (B) Position of adjustment nut (~ 5 mm)          (C) Adjustment space (<math>\pm 5</math> mm)          (D) Spacer plate (if required)</p>  <p>Fig. 175</p> <p><b>Let engine sit for 48 hours then check alignment, tighten center nut to 120 Nm</b></p>
---	--

### 21.3.2 Engine mounts

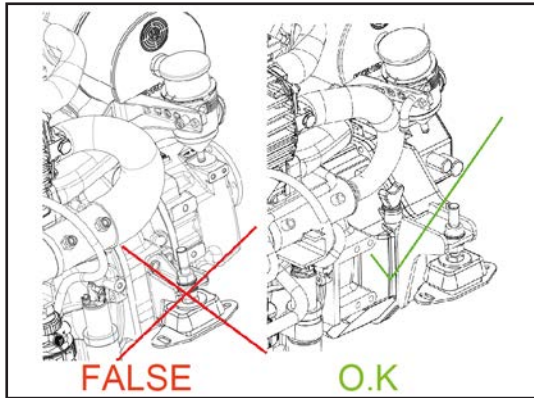
<p><b>2</b></p> <p><b>Engine mounts</b></p> <p><b>If a gear box is in use:</b>          Ensure rear engine mounts always mounted on gear box!</p>	 <p>Fig. 176</p>
---	--

20.3.3 Lifting points

**3** **Lifting points**

**6 cylinder engine**

Never put the engine directly on the floor, this will damage the oil pump!

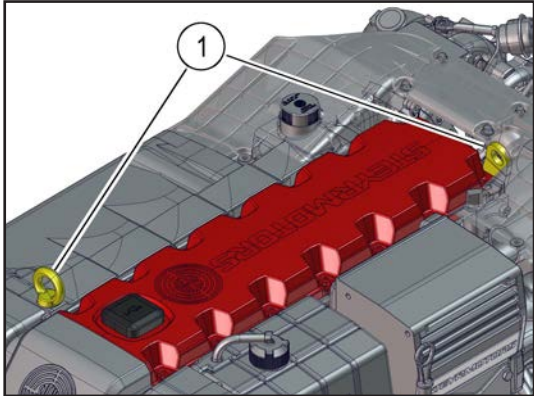

Fig. 177

**4 cylinder engine**

Never put the engine directly on the floor, this will damage the oil pump!

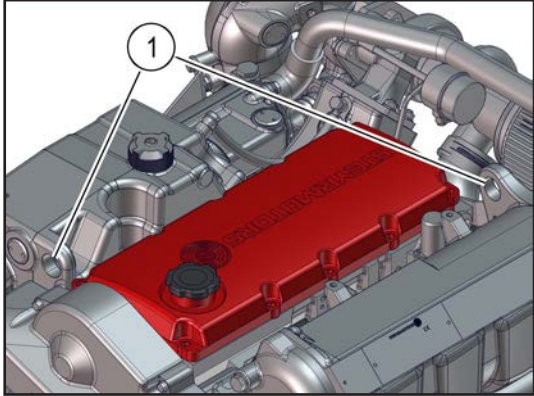

Fig. 178

20.3.4 Space for maintenance

**4** **Space for maintenance**

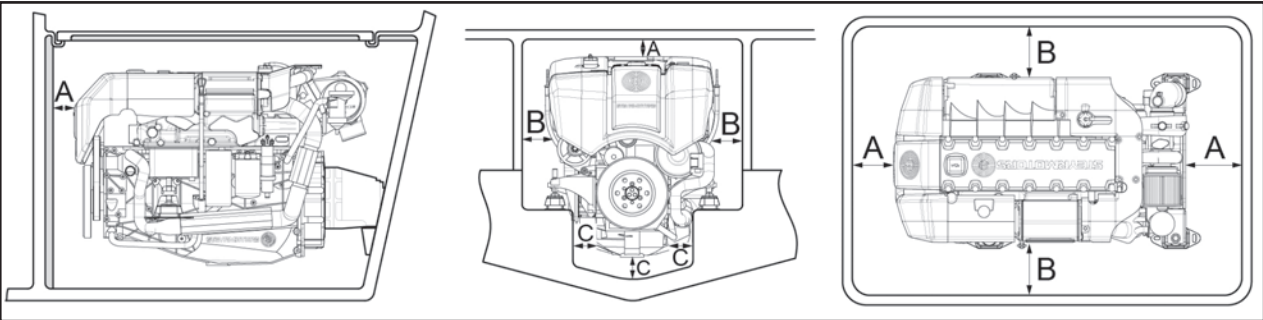

Fig. 179

A	B	C
min. 200 mm	min. 150 mm	min. 20 mm
min. 7.87 "	min. 5.91 "	min. 0.79 "

## 20.3.5 Engine angle

5

## Engine angle

A = 10 deg max.  
B, C, D = 5 deg max.

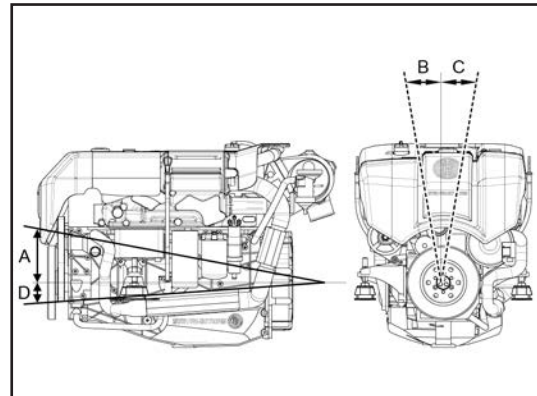

Fig. 180

## 20.3.6 Air and ventilation

6

## Air

The engine room must have enough ventilation with inlet and outlet vents;  
Pipe cross section (for supply & exhaust air) = 1.65 x engine power in kW

Example:

SE186E38 =  $129 \times 1.65 = 212.9 \text{ cm}^2$  or  
164.6 mm diameter

Inlet and outlet must be at front of engine to allow correct circulation of air over to alternator and in engine room box!

Enforced ventilation with bilge blower to evacuate ambient air around turbo charger.

Especially recommended for engines with a VTG turbo charger.

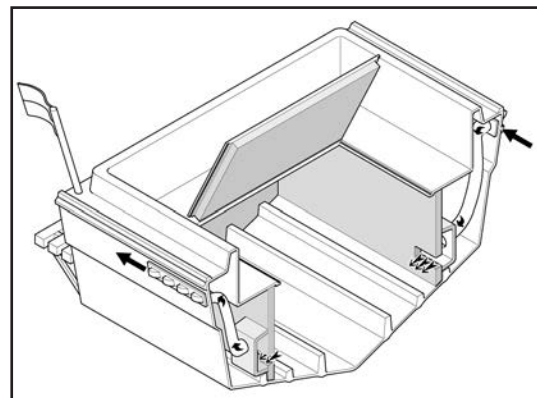

Fig. 181

20.3.7 Raw water

**7 Raw water**

Suction hose connection = 32 mm Ø

A flow rate > 150 l/min

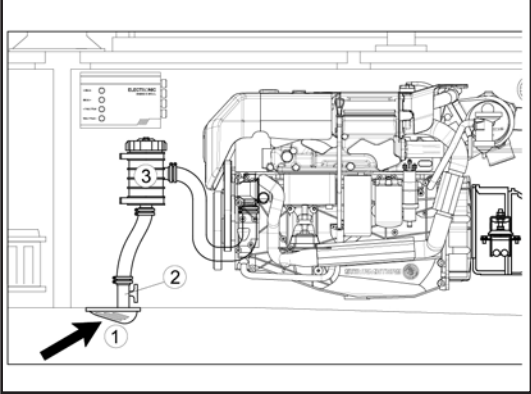
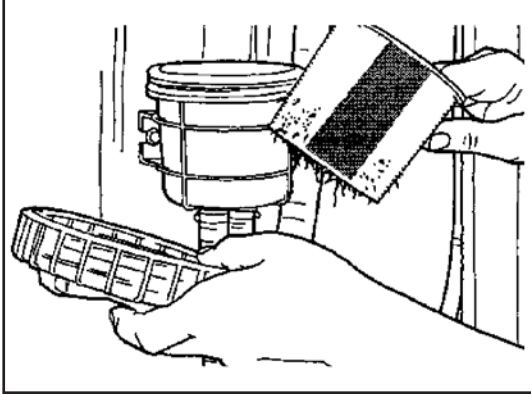



Fig. 182

Fig. 183

**Fit a raw water filter with easy access**

**Full mark system or glass top and a metal filter**

20.3.8 Clean fuel

**8 Clean fuel**

**Fuel supply line:**  
 < 6 m Minimum 12 mm inside diameter  
 > 6 m Minimum 16 mm inside diameter

**Fuel return line:**  
 Minimum 8 mm inside diameter

(1) Feed line  
 (2) Fuel filter  
 (3) Fuel supply pump  
 (4) Fuel return

(5) Coarse filter  
 (6) Water separator  
 (7) Anti syphon valve

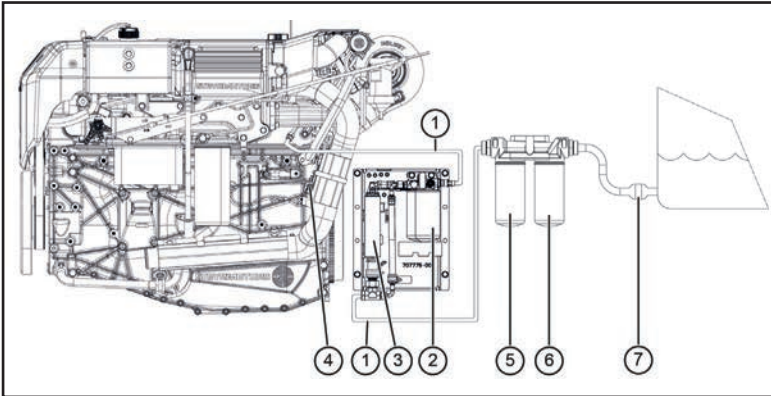



Fig. 184

Fig. 185

**Max. suction height of the fuel supply pump = 0.5 m**

**Water separator capacity must be equal to or greater than 350 l/hr**

**Sieve in fuel pick-up pipe in Tank**

## 20.3.9 Exhaust system

9

## Exhaust system

After assembly of the exhaust system always check back pressure.  
Too high back pressure may cause engine damage and power reduction!

This can easily be done by a gauge to the position where the exhaust water temperature sensor is normally mounted on the exhaust elbow / high riser.

- (1) Exhaust gas elbow
- (2) Connecting piece
- (3) Splash flap
- (4) Tail pipe with flange

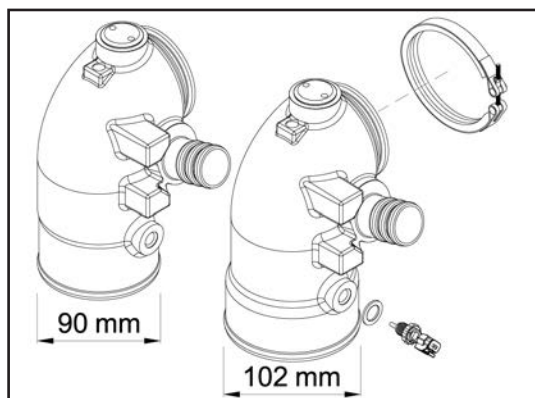

Fig. 186

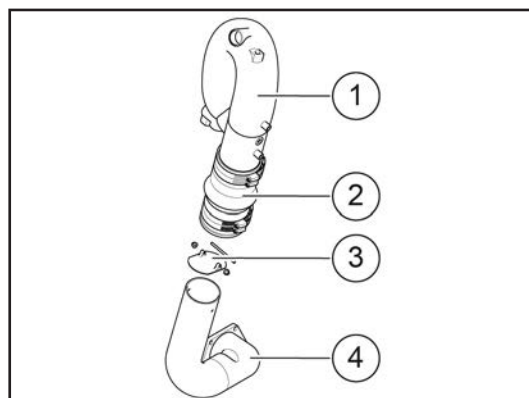

Fig. 187

**Steyr Motors**

Exhaust elbow outside diameter

**d**

90 mm

102 mm

3.5"

4.0"

**Back pressure:****Tolerance values must be ensured!**

The allowed back pressure is  
150 mbar + 0 / - 50 mbar

20.3.10 Inboard installation

10

Inboard installation

The exhaust outlet in the hull should be be 300 mm (12") below the exhaust elbow center line.

The highest part of the exhaust system must be minimum 300 mm (12") above the water line with a normal boat load.

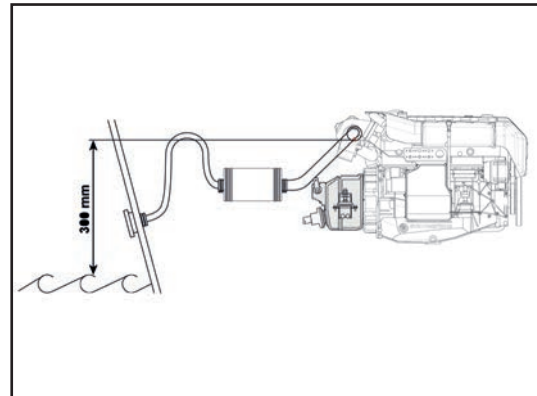

Fig. 188

**Wet Exhaust system for Inboard Engines below water line**  
 (reference point "A" = 300 mm above waterline or lower, referred to lower edge of turbo charger)



**Red marked Parts are not included** in scope of delivery from Steyr Motors. Installation of air vent and exhaust system must be designed from installing party that no backflash-water enter in the exhaust system of the engine during operation and engine stop.

**Variant A - combined waterlock/muffler**

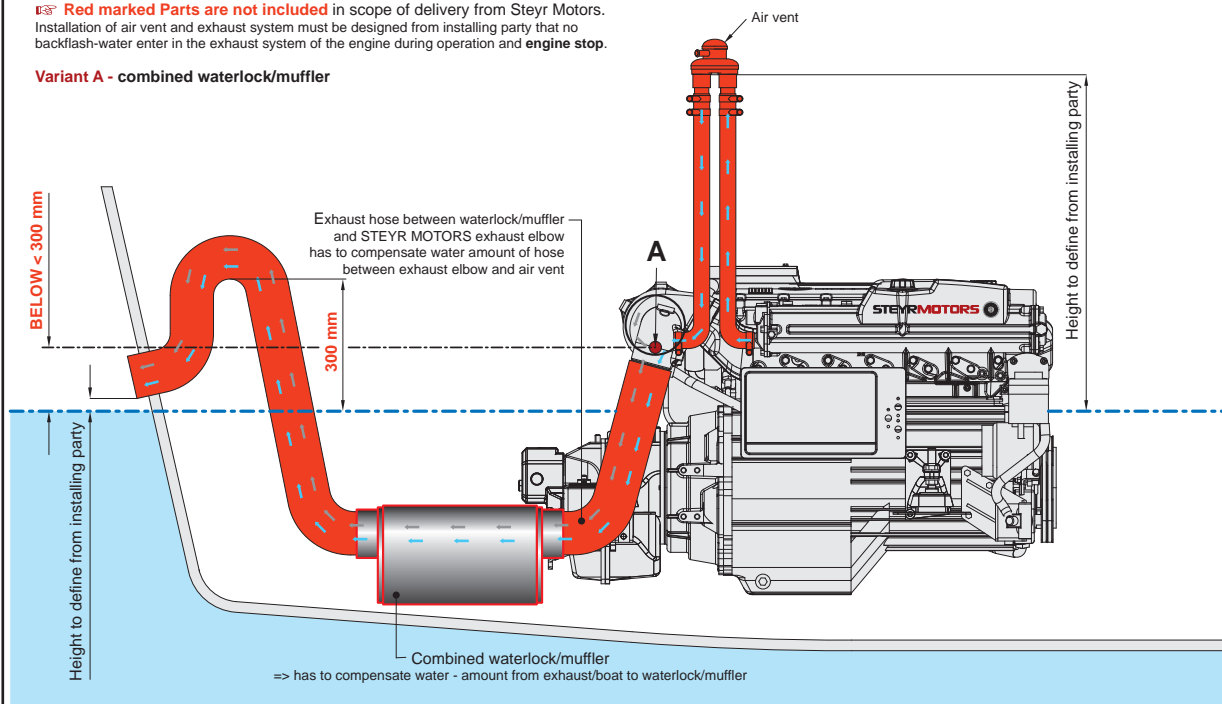

www.steyr-motors.com

2180632-0\_01\_210315

Fig. 189

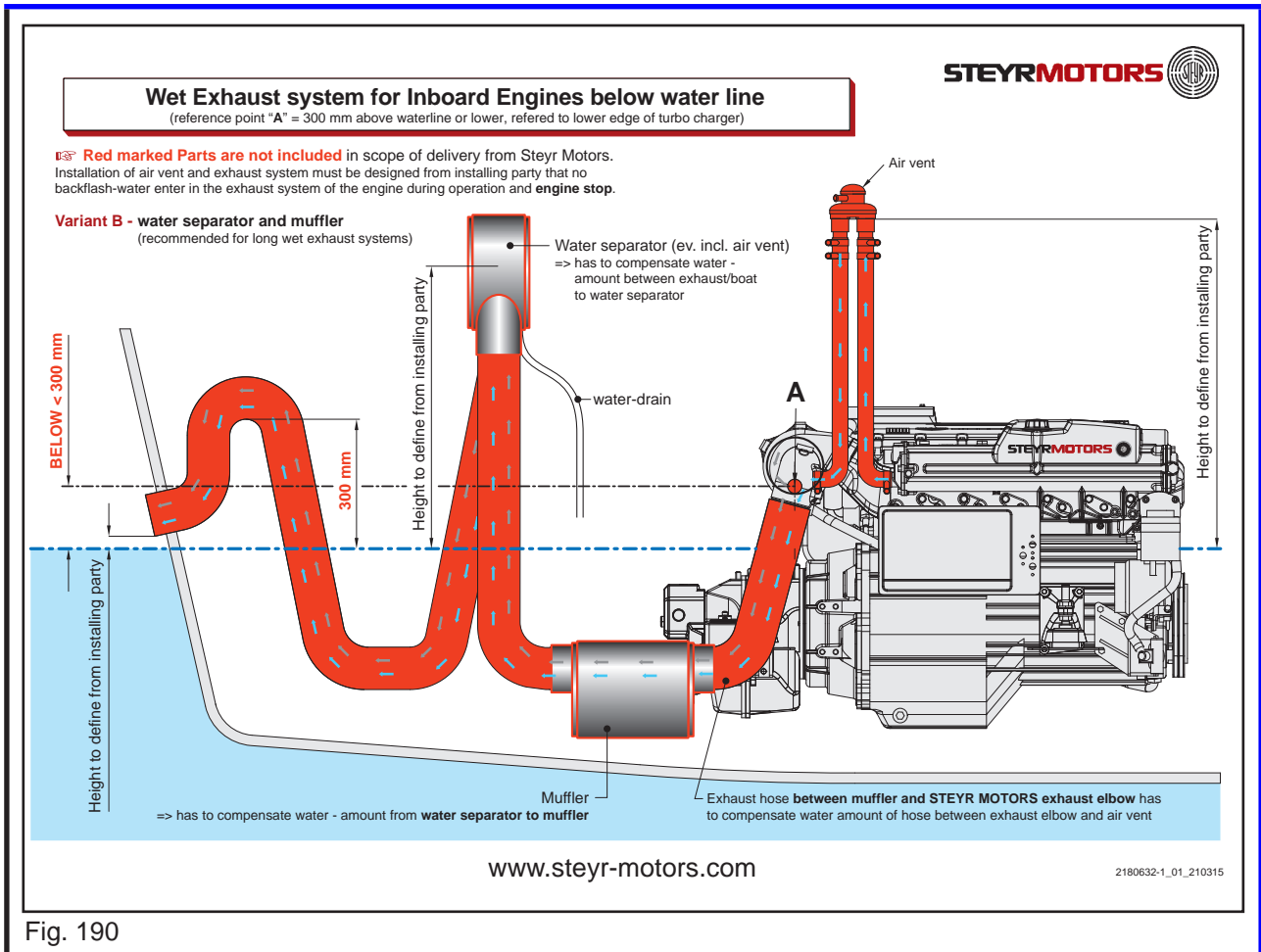

### 20.3.11 Stern drive installation

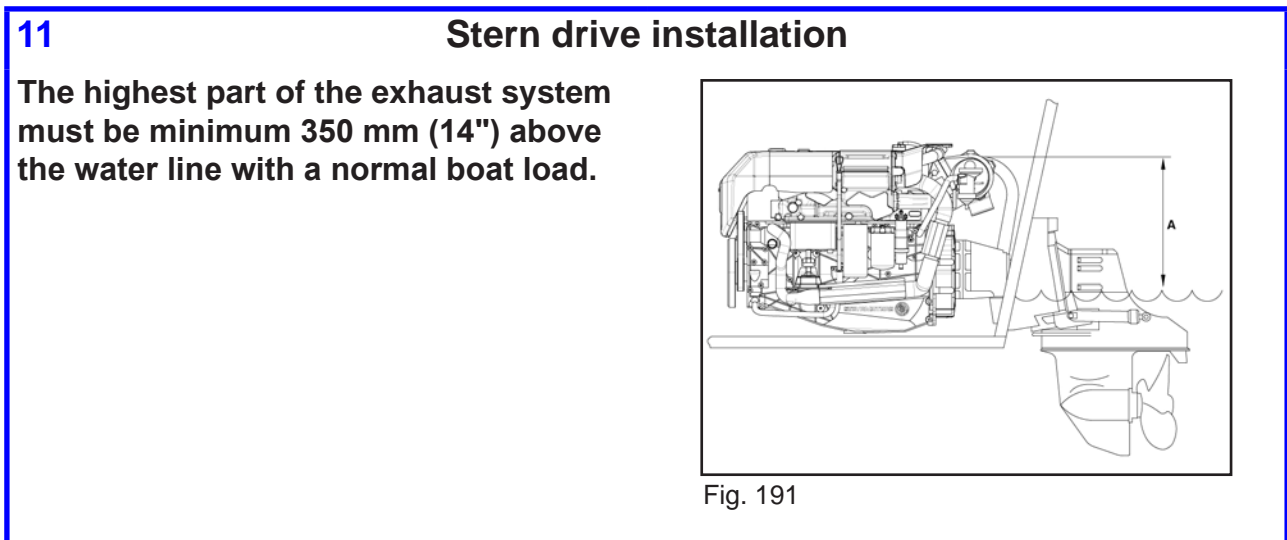

20.3.12 Propeller selection

**12 Propeller selection**

Your **Steyr Motors** marine dealer has chosen a propeller designed to deliver top performance and economy under most conditions. To obtain the maximum percentage of available power output (A), the engine RPM at **full throttle** should be in the specified **propped speed range** (←B→). As to specifications, see Technical Data and Maintenance.

If the engine's full throttle RPM with normal load is below the specified range, use a propeller with less pitch to increase the RPM. Should the engine's full throttle RPM exceed the specified range, the engine RPM and output is limited by the governor. Use a propeller of higher pitch to achieve a RPM reduction in the specified range (←B→).

**NOTICE**

Engine damage can result from incorrect propeller selection if:

- The engine RPM **does not attain** the specified "**Propped speed range**".  
The engine thus runs in RPM range (←C→). Therefore, use a propeller with a **lower pitch**.
- The engine RPM **exceeds** the specified "**Propped speed range**".  
Engine speed is therefore above the admissible range (←D→). Therefore, use a propeller with a **higher pitch**.

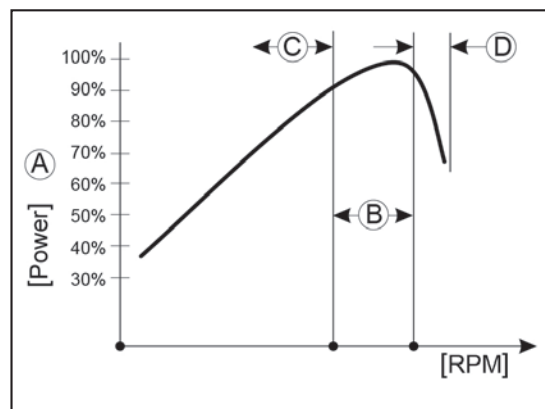

Fig. 192

Engine model		Propped speed range "B"		
		Rated speed [rpm]	Selection range [rpm]	
			Standard propeller / Stern drive	Jet drive
6 cylinder	SE126E32	3200	2800 - 3250	2550 - 3250
	SE156E34	3400	3100 - 3450	2800 - 3450
	SE186E38	3800	3500 - 3850	3300 - 3850
	SE236E40	4000	3900 - 4100	3700 - 4100
	SE236S36	3600	3400 - 3650	3300 - 3650
	SE266E40	4000	3850 - 4050	3700 - 4050
	SE266S36	3600	3300 - 3650	3300 - 3650
	SE286E40	4000	3900 - 4150	3700 - 4150
	SE306J38	3800	n.a. (Jet only)	3600 - 3850
4 cyl.	SE144E38	3800	3700 - 3850	3300 - 3850
	SE164E40	4000	3900 - 4050	3550 - 4050

## 21 Operating and auxiliary materials

Order number	Short text	SMO item	Alternative item
10084	Hot bearing grease	Staburags NBU4	
11104	Engine oil	Mobil Delvac 1350	
12222	Copper grease	Staloc® copper paste	
12385	Ultra Clean	Ultra Clean Techn. quick detergent	
50475	Preservation oil	TITAN EM 2020 DEUTZ	
500830	Engine oil	ACEA-, API-Service codes 10W-40	
500831	Coolant	SMO-Coolant Premium Ready Mix R40-G (5L Can.)	
700429	Protection wax	BERNER 400 ml-Spray	
702280	Lubricant	Staloc Blue Moly 500 g	
705442	Injector grease	Tube 20 g	
706992	PTFE-Special grease	Can 500 g	
9000017-0	Screw lock compound, high strength	Staloc 2S62 (red)	Loctite 262 (red)
9000019-0	Seat sealing compound, high temperature	Staloc 6S20 (green)	Loctite 620 (green)
9000059-0	Screw lock compound, medium	Staloc 2S43 (blue)	Loctite 243 (blue)
9000297-0	Surface sealing compound, medium strength, flexible	Staloc 5S18 (red)	Loctite 518 (red) Loctite 5182 (red)
9000510-0	Surface sealing compound, black	Staloc Silicone sealant	Loctite 5900 (black)
9000540-0	Two component adhesive	Staloc Power 703	

THIS PAGE IS INTENTIONALLY BLANK





**Steyr Motors AG**

Im Stadtgut B1 | A-4407 Steyr-Gleink | Austria

[www.steyr-motors.com](http://www.steyr-motors.com)